

**LUCK®**  
**TAMPON**

**Spitzenqualität  
für Profis**  
*Top Quality  
for Professionals*



**Gesamtkatalog**  
**Catalogue**



**Jens-Peter Lück**  
Geschäftsführer  
*Directing Manager*

## Willkommen bei Tampon-Technik

Tampon-Technik ist seit Jahren ausschließlich auf die Produktion von hochwertigen Drucktampons spezialisiert. Sie, verehrte Kunden, haben uns zu einem führenden Produzenten von Drucktampons in Deutschland werden lassen, dessen Geschäftskontakte von Australien bis in die USA reichen. Der Lück-Tampon, ist ein Synonym für Qualität. Dieser Erfolg basiert auf 3 Prinzipien:

- 1- individuelle Kundenberatung von erfahrenen Fachleuten
- 2- absolute Qualität
- 3- kurzfristige Lieferzeiten.

Wir bieten Lösungen für den wirtschaftlichen Einsatz von Drucktampons:

- auf rauen Oberflächen
- auf leicht zerbrechlichen Material
- als Mehrfarbendruck
- in sehr kleinen Aussparungen
- auf unebenen Produkten

Jahrzehntelange Berufserfahrung im Druckgewerbe prägen unsere Beratung. Wir setzen Ihre Erwartungen um und machen das Machbare möglich. (Falls nötig selbst vor Ort) Nutzen Sie unser Know-How und stellen Sie fest, dass die Tampon-Druck-Technologie eine wirtschaftliche Alternative zu anderen Druck-Technologien sein kann. Wir beraten Sie in jedem Fall gern.

## Welcome to Tampon-Technik

For years Tampon-Technik is exclusively specialised in the production of high quality printing pads. Thanks to you, dear customer, we have become one of the leading manufacturers of printing pads in Germany. Our business contacts reach from Australia to the USA. The Lück printing pad is a synonym for quality. This success is based on 3 principals:

- 1- Individual customer advisory by experienced experts
- 2- Highest quality
- 3- Short delivery term.

We offer solutions for a profitable use of printing pads:

- On rough surfaces
- On extreme fragile materials
- As multicolour printing
- In cavities
- On uneven products

Decades of professional practise in the printing branch set the tone of our advisory service. We implement your expectations and make feasible tasks possible (if necessary at your site). Make use of our know-how and find out that the printing pads technology presents an economical alternative to other printing methods. We look forward to offering you our advisory services.

## Hochleistungs-Drucktampons

*Lück-Tampons*® werden aus hochwertigen Rohstoffen hergestellt. Diese garantieren:

- höchste Druckqualität
- höchste mechanische Dauerbeanspruchung
- langfristige Konstanz der Shore-Härte
- keine Zersetzung bei aggressiven Farben

Alternativ zu unserem empfehlenswerten roten Material bieten wir an:

- weiße Qualität  
ermöglicht ein besseres Erkennen des Druckbildes auf dem Stempel
- schwarze und blaue Qualität  
besitzen ein geringeres statisches Aufladungspotential
- gelbe Qualität  
eignet sich zur manuellen Nachbearbeitung des Drucktampons (z.B. Beschneiden) und zeichnet sich durch ein brillantes Druckbild aus

## Härtegrade

*Lück-Tampons*® werden in allen gängigen Härtegraden produziert. Die technische Untergrenze liegt bei ca. 25 Shore 00. Die mittleren Shore A Härten nach DIN 53505 können wir stufenlos bis ca. 25 Shore A anbieten. Härtebereiche oberhalb dieser Spanne (z.B. für Silikonwalzen) liefern wir auf Anfrage.

## Oberfläche

*Lück-Tampons*® werden mit verschiedenen Oberflächenbeschaffenheiten angeboten. Das Spektrum reicht von supertrocken (z.B. für Metalldruck) bis superfeucht (für dickeren Farbauftrag). Auf Wunsch stellen wir auch Zwischenwerte und Extremoberflächen her. Sollten Sie keine speziellen Angaben machen, erhalten Sie die bevorzugte normale Oberfläche.

## Sonderwünsche

Die *Lück-Tampon*® Produktpalette wird ständig den neuesten technischen Anforderungen angepasst und erweitert. Sie umfaßt zur Zeit ca. 1000 verschiedene Tamponformen, welche nicht alle im Katalog dargestellt werden konnten. Falls Sie einen Tampon benötigen, der nicht im Katalog aufgeführt ist, liefern wir diesen selbstverständlich auf Anfrage. Natürlich produzieren wir auch Sondertampons, die speziell auf Ihre Anforderungen abgestimmt sind.

Am Ende des Kataloges finden Sie ein  
**Bestellformular**  
zur schnellen Auftragsübermittlung (z.B.Fax)

## High-performance printing pads

Lück printing pads are mainly fabricated out of high-grade red raw materials. They guarantee:

- highest printing quality
- highest mechanic continuous stress
- long-term constancy of shore hardness
- no decomposition due to aggressive colors

Of course we offer also other qualities if desired:

- white quality  
enables to a better recognition of the printing format on the pad
- black and blue quality  
have a lower static charging potential
- yellow quality  
is suitable for manual finishing of the printing pad (e.g. trimming) and is characterised by a brilliant printing format.

## Degree of hardness

Lück printing pads are produced in all marketable degrees of hardness. The technical lower limit lies at approx. 25 shore 00. We can offer mid shore A hardness`s according to DIN 53505 infinitely variable up to ca. 25 shore A. Hardness`s which exceed this range (e.g. for silicone rollers) can be delivered on request.

## Surface

Lück printing pads are offered with varying surface structures and qualities reaching from extra dry (e.g. for metal-printing) to extreme humid (for thicker colour application). On request we also produce intermediate values and extreme surfaces. In case you do not communicate to us your particular specification we provide the most favourable normal surface.

## Options

The Lück printing pads product range is constantly adjusted and extended according to the latest technical requirements. At present we can offer about 1000 different printing forms - impossible to present them all in our brochure. In case you need a printing pad not shown in our brochure it goes without saying that we will supply it on your request. Of course we also produce special pads designed for our customer`s requirement only.

At the end of our catalogue you will find an  
**ORDER FORM**  
for fast order transmission (e.g.fax)

# LÜCK®

## TAMPON

### Hohle Drucktampons

Alle *Lück-Tampons*® können prinzipiell hohl gefertigt werden. Aus diesem Grund haben wir verzichtet, diese in den Katalog aufzunehmen. Anhand der Preisliste können Sie erkennen, welche Tampons schon jetzt hohl angeboten werden.

Die Drucktampon Nr.: 142H30 bedeutet zum Beispiel, dass in dem Drucktampon Nr. 142 sich ein Hohlkörper in der Grösse des Drucktampon Nr. 30 befindet. Sämtliche Drucktampons deren Nummer ein H beinhaltet sind hohl. Auf Wunsch fertigen wir kurzfristig Ihren *Lück-Tampon*® hohl an.

### Auswahlkriterien

Die Grössenauswahl des Drucktampons ist abhängig vom Druckbild und dem Grad der Deformation des Drucktampons beim Druckvorgang.

Die Härteauswahl des Drucktampons ist abhängig von der Form des Druckgutes und der gewünschten Druckqualität.

Weiche Drucktampons verfügen über einen dickeren Farbauftrag. Sie passen sich stark gebogenen Teilen gut an und neigen zur homogenen Farbverteilung. Dieser Aspekt kann zum gleichmäßigen Farbauftrag auf Vollflächen und Strukturflächen genutzt werden. Nachteilig ist ihr eher unsauberes Druckbild und die verstärkte Neigung zu Lufteinschlüssen.

Harte Drucktampons verfügen über ein sauberes Druckbild, insbesondere auf Strukturoberflächen. Es bilden sich weniger Lufteinschlüsse. Nachteilig ist der geringere Farbauftrag, sowie die nur bedingte Eignung auf stark gewölbten Teilen.

Hohle Drucktampons unterstützen das Drucken auf sehr stark gebogenen Teilen.

### Behandlung und Pflege

Die *Lück-Tampons*® am besten mit weichem, Alkohol oder Verdünner getränkten Reinigungspapier abreiben, bis die Oberfläche matt ist. Die Oberfläche kann durch trocken reiben oder den Einsatz der Handfläche beschädigt werden (Radiergummi-Effekt). Der Drucktampon kann sich bei längerem Dauereinsatz plastisch verformen. Hier empfiehlt es sich, den Tampon rechtzeitig auszutauschen. Diese Verformungen sind reversibel und bilden sich nach mehreren Stunden zurück.

### Umweltverträglichkeit

*Lück-Tampons*® gewährleisten bedenkenlos einen lebensmittelechten Druck. Verbrauchte Druckstempel können Sie unproblematisch über den Restmüll entsorgen.

### Hollow printing pads

On principal all Lück printing pads can be fabricated as hollow types. Therefore, we refrained from giving them a place in our catalogue. The price list clearly shows which printing pads are already now available as hollow pads.

For example printing pad no.: 142H30 means that printing pad no. 142 includes a hollow body with the size of printing pad no. 30. All printing pads with an article number that includes an H are hollow. On request we fabricate on short term your hollow Lück printing pad.

### Selection criteria

Selection of the printing pad size depends on the printing format and the degree of deformation of the printing pad during the printing process.

Selection of hardness depends on the form of the goods to be imprinted and the desired printing quality.

Soft printing pads provide a thicker color application. They adapt themselves enormously to bent parts and tent to an homogenous color distribution. This aspect can be used for an even color application onto all-over surfaces and structural surfaces. Disadvantageous is their rather unclean format and the improved tendency to inclusions of air.

Hard printing pads provide a clean printing format, in particular on structural surfaces, and less inclusions of air occur. On the other hand the disadvantage is that less color is applied and that the pads are less suitable for strongly curved parts. Here hollow printing pads can support the print onto strongly bent parts.

### Treatment and care

The best method is to rub Lück printing pads with soft cleaning paper soaked with alcohol or diluent until the surface becomes matt. The surface can be damaged through dry rubbing or use of the hands palm (rubber effect). The printing pad can deform plastically when using it permanently. Here we recommend to exchange the pad early enough. These deformations are reversible and return to their original form after a few hours.

### Environmental aspects

Without hesitating Lück printing pads guarantee food-suitable printing. Utilized printing pads can be disposed of with the normal garbage.

## Inhaltsverzeichnis

-  runde Drucktampons  
Seiten 6-16
-  sattelförmige Drucktampons  
Seiten 17-21
-  eckige Drucktampons  
Seiten 22-46
-  längliche Drucktampons  
Seiten 47-66
-  Sonder Drucktampons  
Seiten 67-82
-  Walzen  
Seite 83
-  Zubehör  
Seiten 84+85



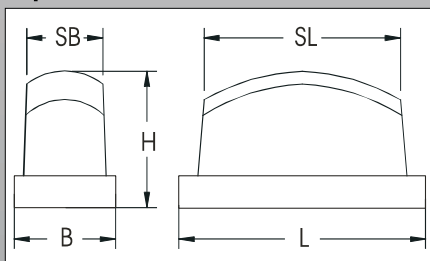

## Zeichenerklärung

- L - Länge
- B - Breite
- H - Höhe
- S - Silikon
- SL - Silikonlänge
- SB - Silikonbreite
- M4 - metrisches ISO-Gewinde mit 4mm  $\varnothing$
- M5 - metrisches ISO-Gewinde mit 5mm  $\varnothing$
- M6 - metrisches ISO-Gewinde mit 6mm  $\varnothing$

### Beispiel



## list of contents

-  round printing pads  
sides 6-16
-  saddle styled printing pads  
sides 17-21
-  square printing pads  
sides 22-46
-  long printing pads  
sides 47-66
-  special printing pads  
sides 67-82
-  silicone rollers  
side 83
-  fitting  
sides 84+85

## sign explanation

- L - length
- B - breadth
- H - height
- S - silicone
- SL - silicone length
- SB - silicone breadth
- M4 - metric ISO-tread with 4mm  $\varnothing$
- M5 - metric ISO-tread with 5mm  $\varnothing$
- M6 - metric ISO-tread with 6mm  $\varnothing$

### example

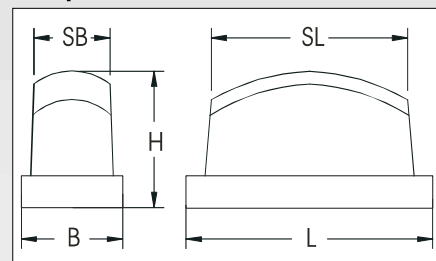



# LUCK® TAMPON

H = Höhe

Nr. 367 Alu

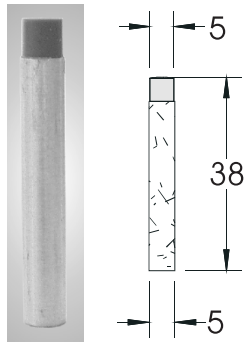

Nr.368 Alu

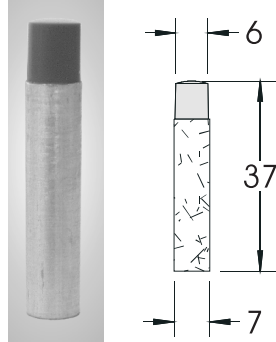

Nr. 363 Alu M4

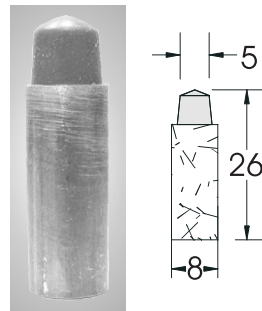

Nr. 366 Alu M4

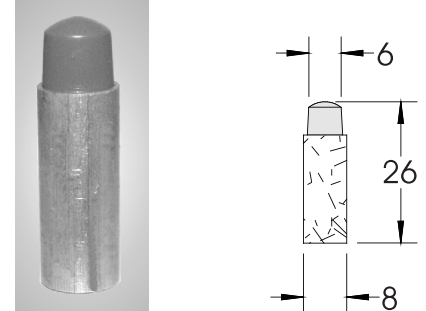

Nr. 197 Alu M5



Nr. 2197 Alu M5 -  
Nr. 3197 Alu M5 -  
Nr. 5197 Alu M5 -  
Nr. 7197 Alu M5 -  
- jeweils anderer Silikonradius  
(different silicone radius respectively)

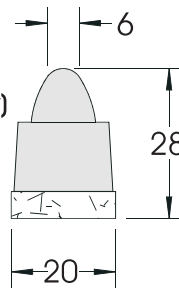

Nr. 2195 Alu M6

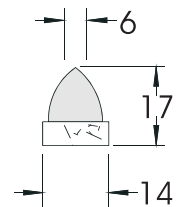

Nr. 362 Alu M6

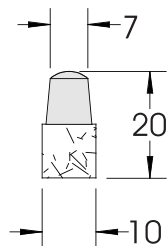

Nr. 745 Alu M5

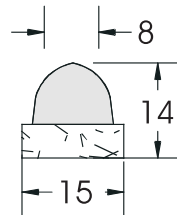

Nr. 361 Alu M6

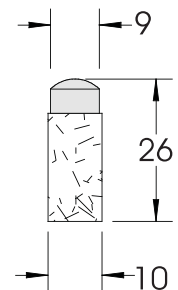

Nr. 364 Alu M6

Nr. 364S Alu M6 H 17  
Nr. 365 Alu M6 H 32

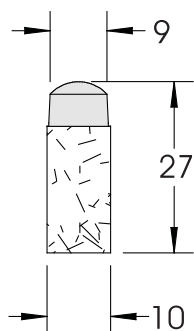

Nr. 375 Alu M6

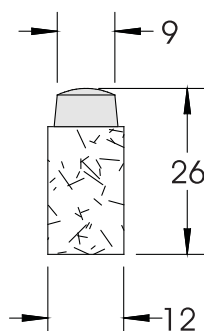

Nr. 369 Alu M6

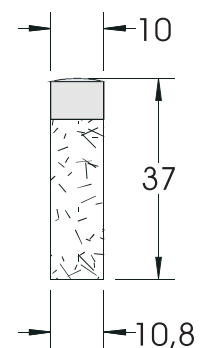

H = height

# LÜCK® TAMPON



Nr. 31 Alu M6

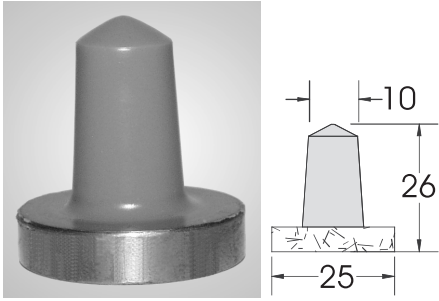

Nr. 1294 Alu M6

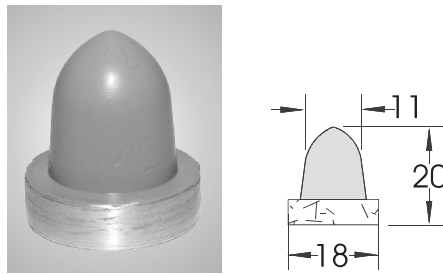

Nr. 198 Alu M6

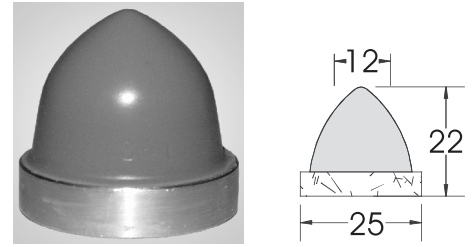

Nr. 579 Alu M5

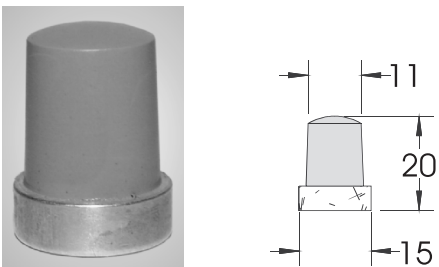

Nr. 580 Alu M6

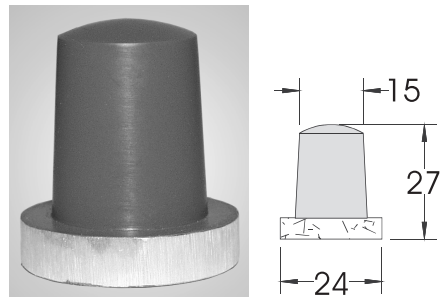

Nr. 32 Alu M6

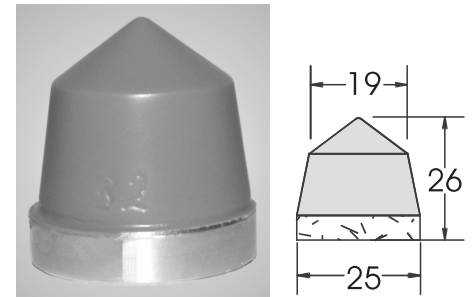

Nr. 12  
Nr. 12 Alu M6 H 30

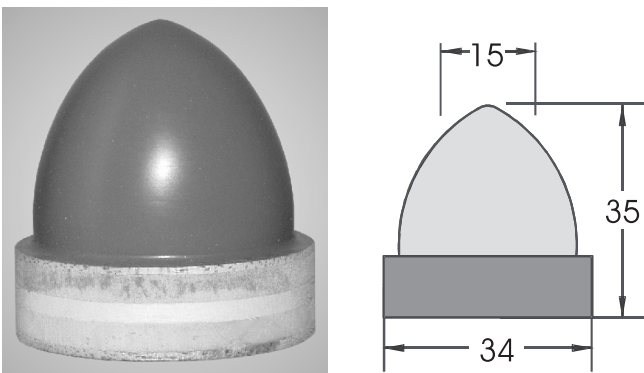

Nr. 12S  
Nr. 12S Alu M6 H 30

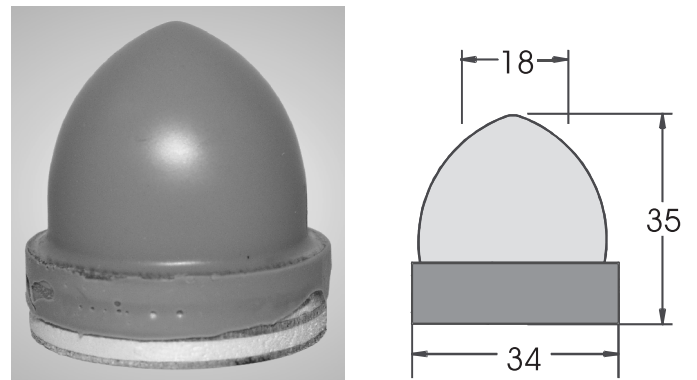

Nr. 709  
Nr. 709 Alu M6 H 29

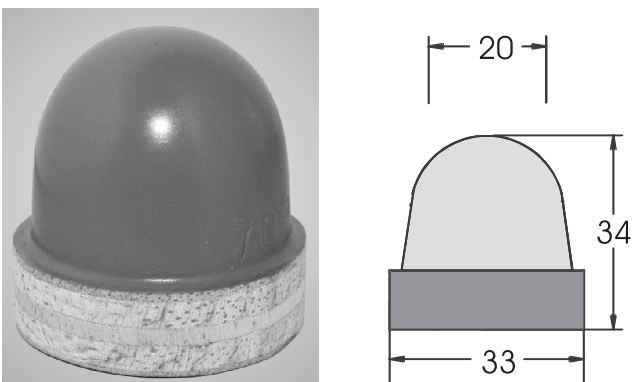

Nr. 97  
Nr. 97 Alu M6 H 35

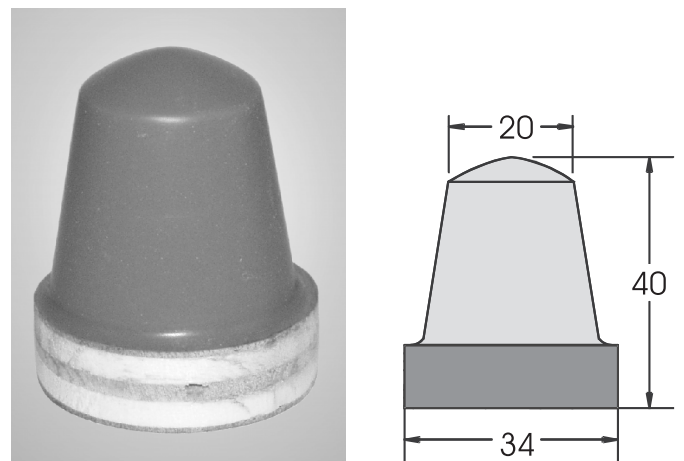



# LÜCK® TAMPON

H = Höhe  
S = Silikon

## Nr. 96 Alu M6

Nr. 96S Alu M6 stärker gewölbt H 29  
(stronger curved)

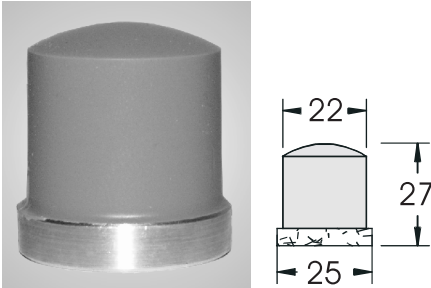

## Nr. 435 Alu M6

Nr. 435 H 38

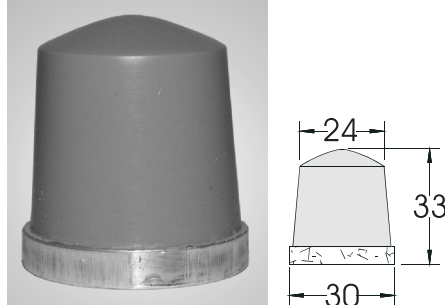

## Nr. 107

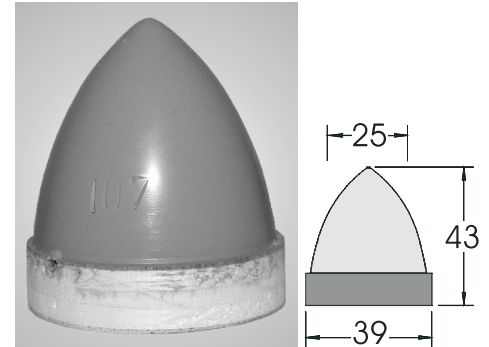

## Nr. 25

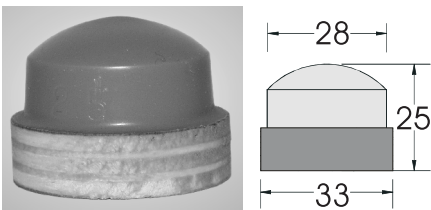

## Nr. 537 Alu M6

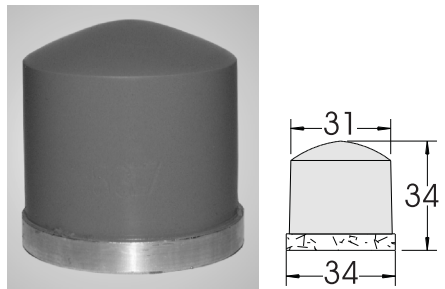

## Nr. 767 Alu M6

Nr. 767 H 43

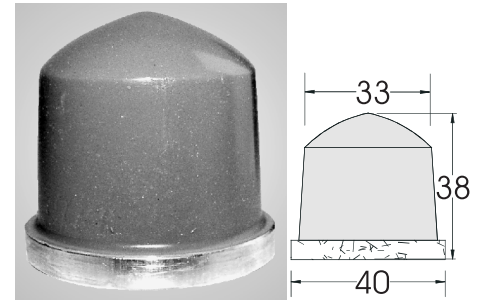

## Nr. 35S

Nr. 35S Alu M6 H 33

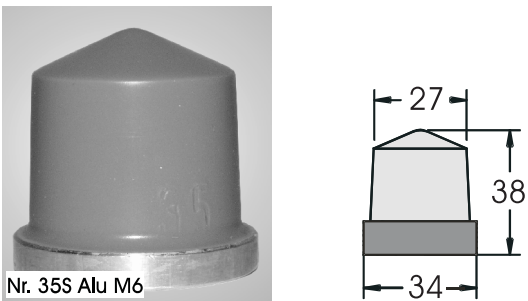

## Nr. 35

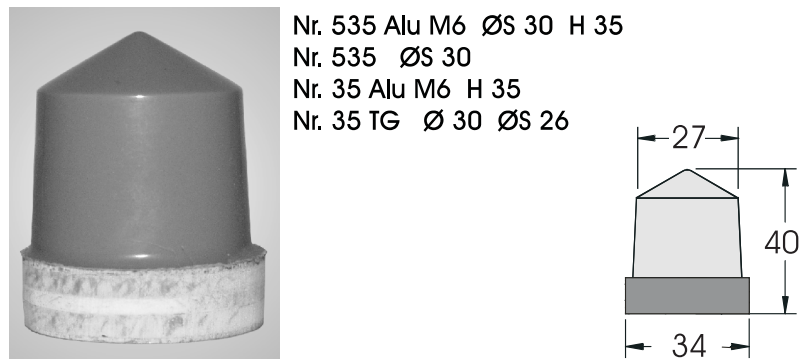

Nr. 535 Alu M6 ØS 30 H 35  
Nr. 535 ØS 30  
Nr. 35 Alu M6 H 35  
Nr. 35 TG Ø 30 ØS 26

## Nr. 647

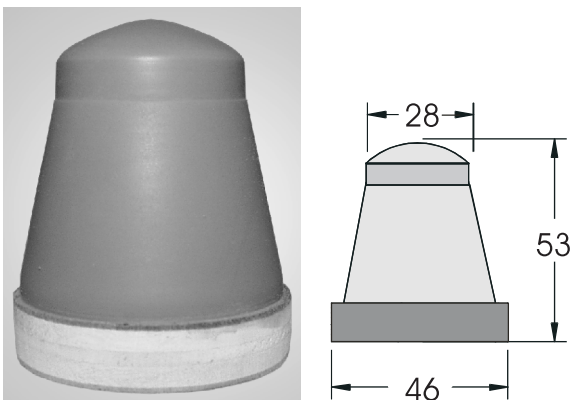

## Nr. 13

Nr. 13K Ø 67 H 53

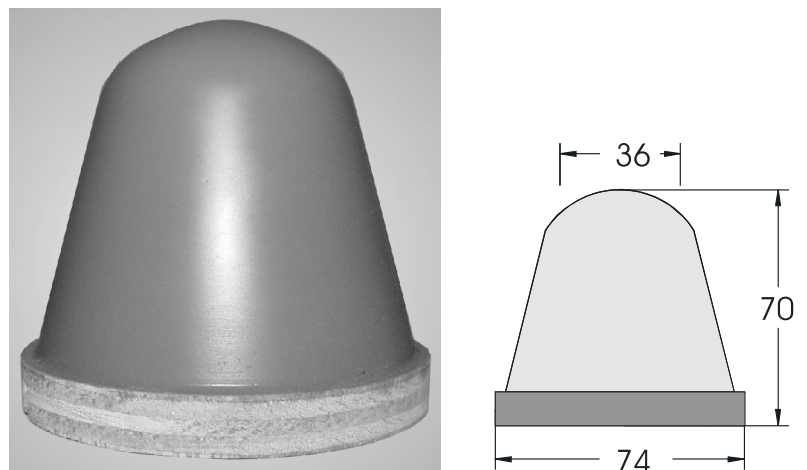



H = height  
S = silicone

# LÜCK® TAMPON



Nr. 13SK

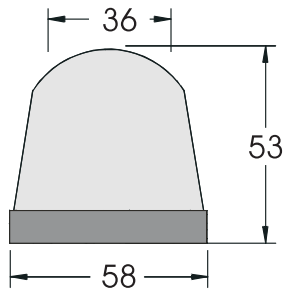

Nr. 56

Nr. 56 Alu M6 H 33

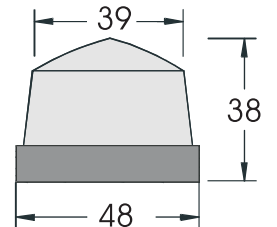

Nr. 36

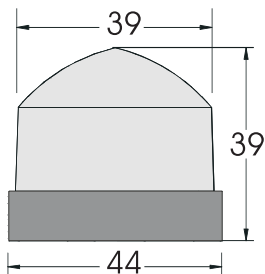

Nr. 536

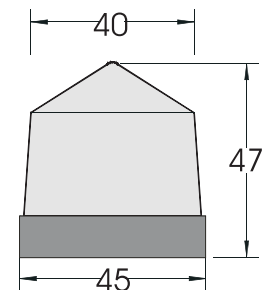

Nr. 52

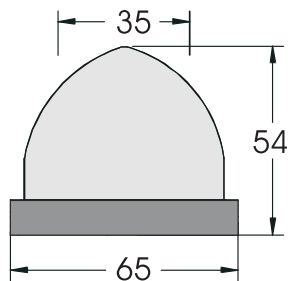

Nr. 111

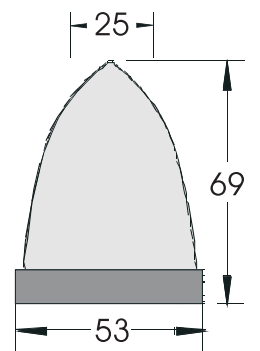

Nr. 28

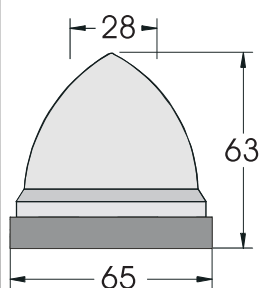

Nr. 26

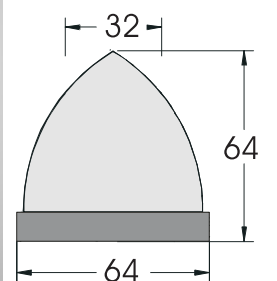



# LÜCK® TAMPON

H = Höhe

Nr. 106

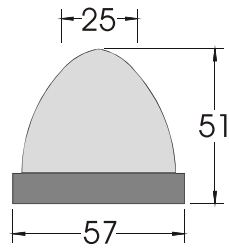

Nr. 40

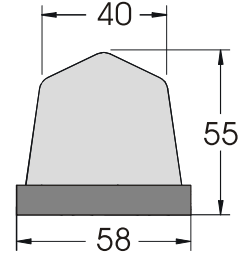

Nr. 636

Nr. 636K H 39

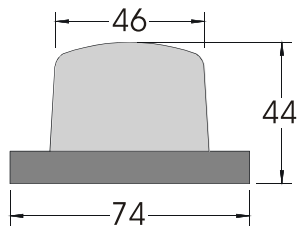

Nr. 711

Nr. 711 Alu M6 H 40

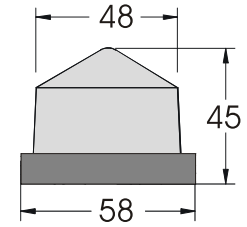

Nr. 37

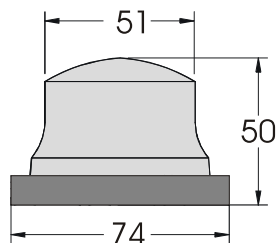

Nr. 57

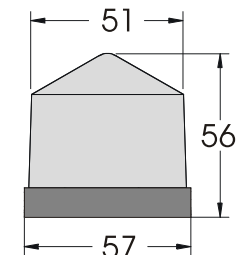

Nr. 465H Alu

hohl, auf Ring-Aluscheibe mit 2 x M6

Nr. 464 H 53 Holz, nicht hohl

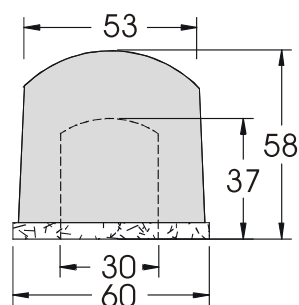

Nr. 112

Nr. 112 Alu M6 H 55

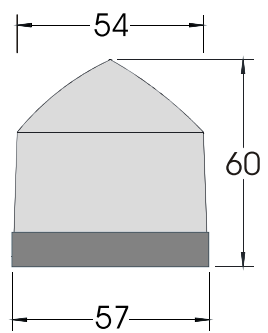

H = height  
 hohl = hollow  
 nicht hohl = not hollow  
 Holz = wood

# LÜCK® TAMPON



Nr. 78

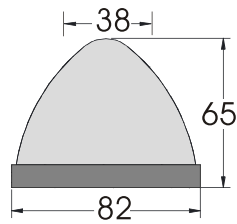
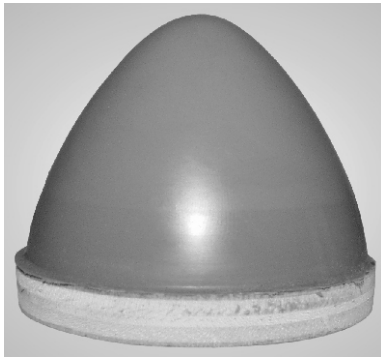

Nr. 110

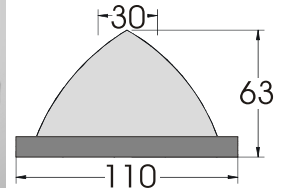
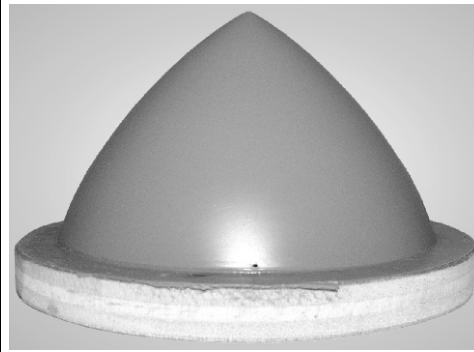

Nr. 126

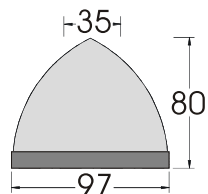

Nr. 109

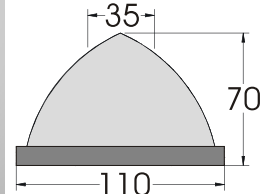
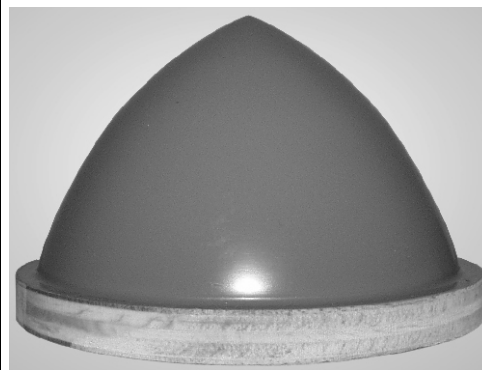

Nr. 127

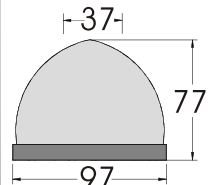

Nr. 50

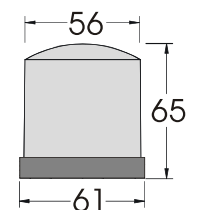
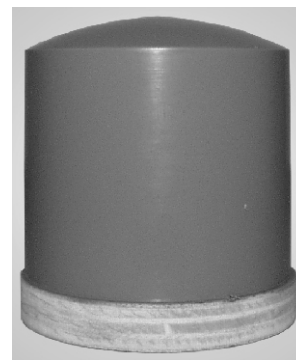

Nr. 39

Nr. 39 Alu M6 H 50

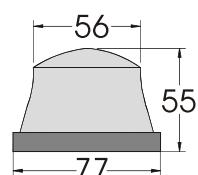

Nr. 131

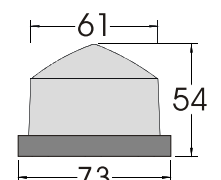
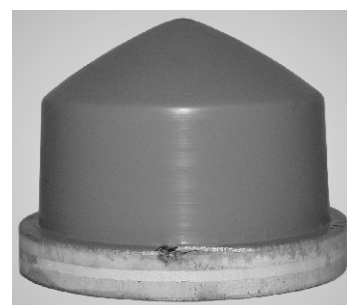



# LÜCK® TAMPON

H = Höhe

Nr. 663

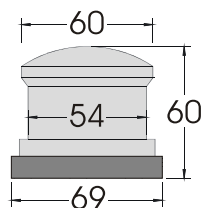

Nr. 463

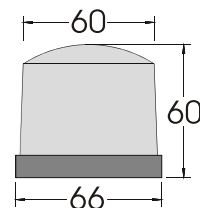
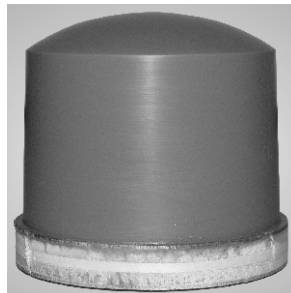

Nr. 41

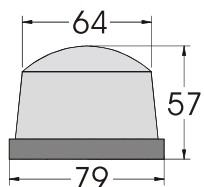

Nr. 130

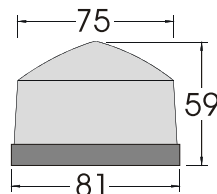
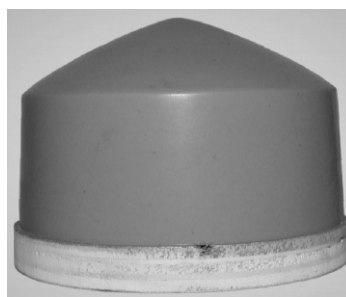

Nr. 108

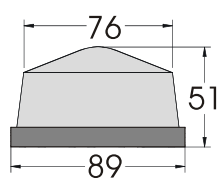

Nr. 135

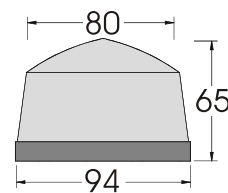

Nr. 42

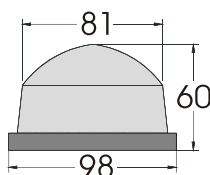
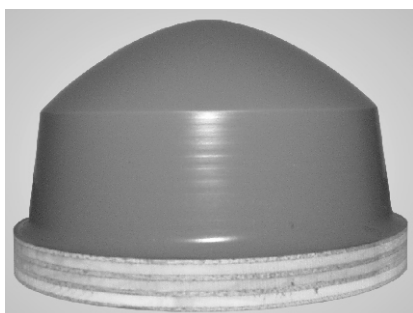

Nr. 113

Nr. 113K H 72

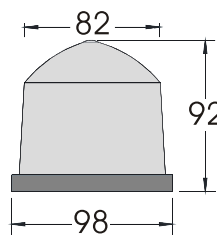

H = height

# LÜCK<sup>®</sup> TAMPON



Nr. 114

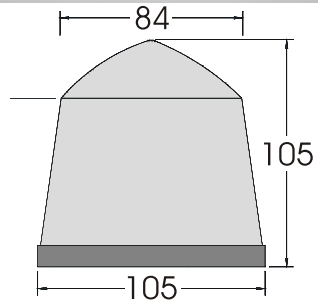

Nr. 125

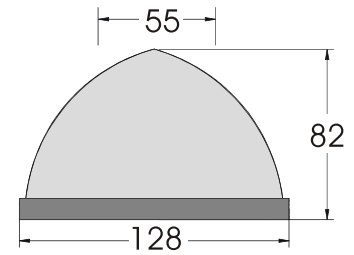

Nr. 158

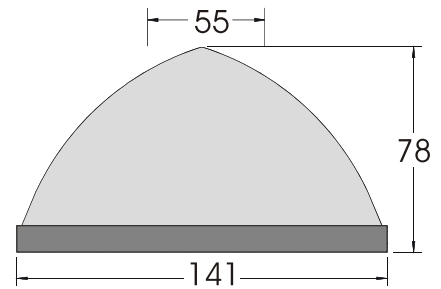

Nr. 156

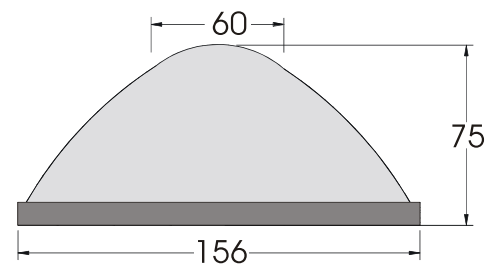
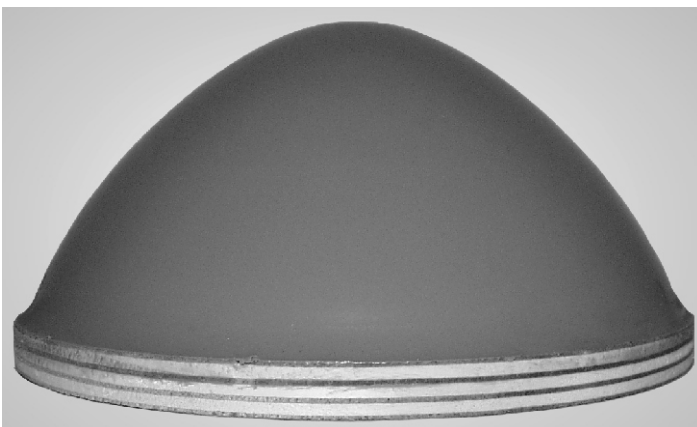



# LÜCK<sup>®</sup> TAMPON



Nr. 124

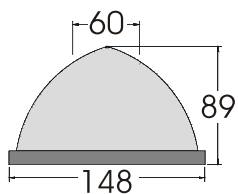
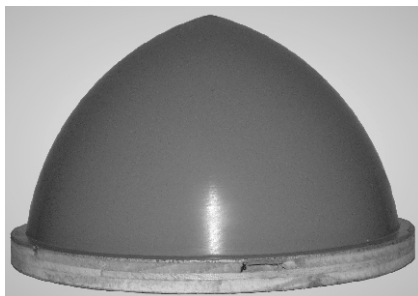

Nr.79

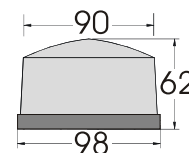
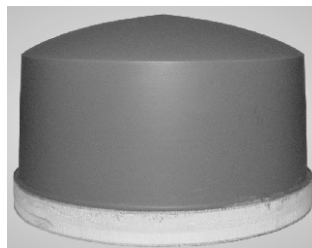

Nr. 152

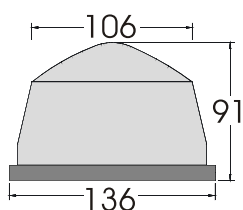

Nr. 160

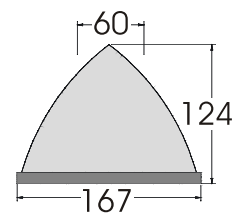

Nr. 165

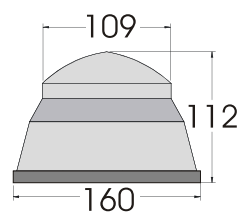

Nr. 155

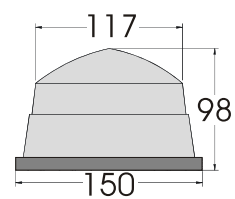

Nr. 154

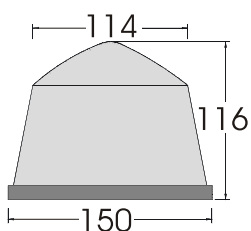

Nr. 150

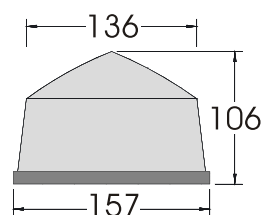



Nr. 170

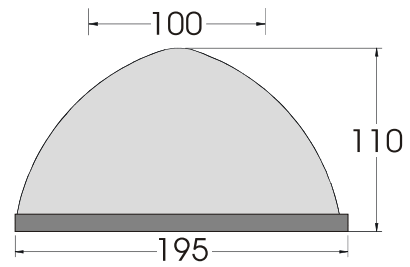

Nr. 190

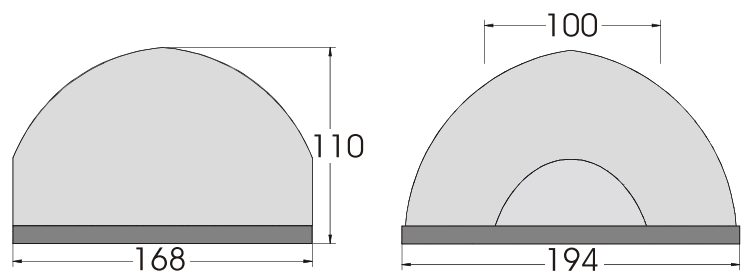

Nr. 300

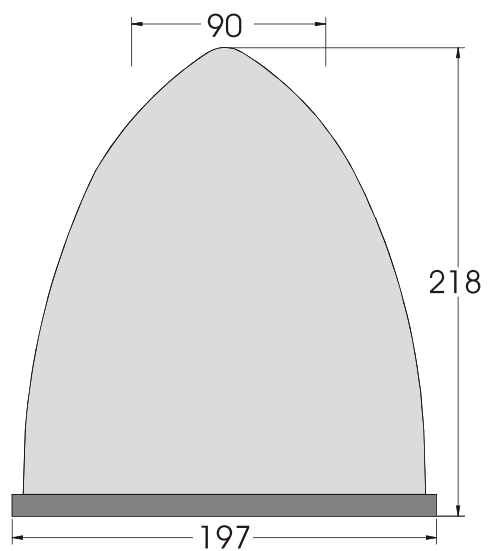



**LÜCK**<sup>®</sup>  
**TAMPON**

H = Höhe

Nr. 302

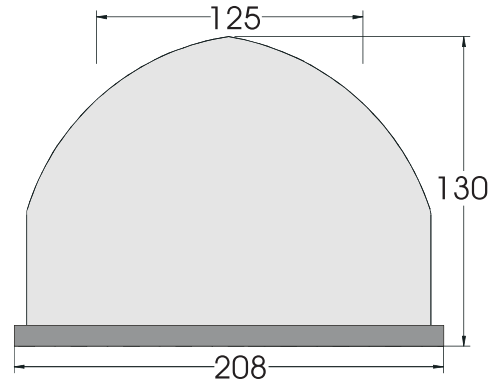

Nr. 153

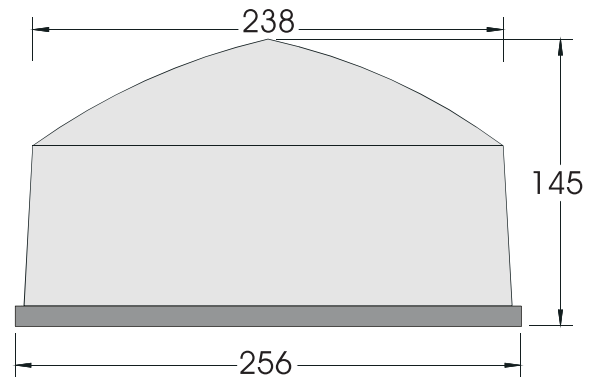
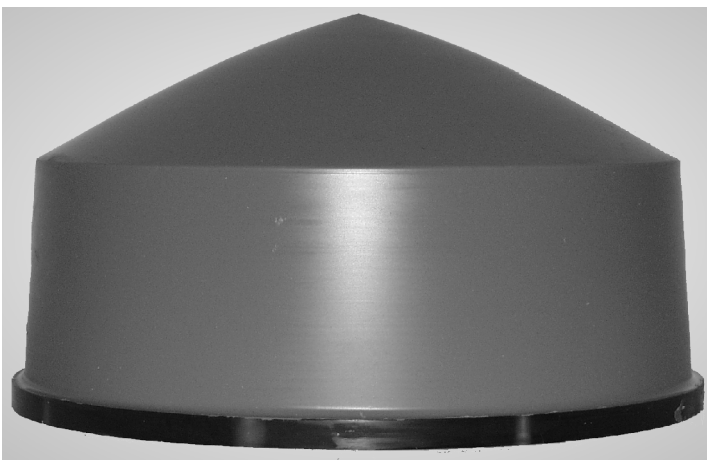



H = height

# LÜCK® TAMPON



Nr. 43

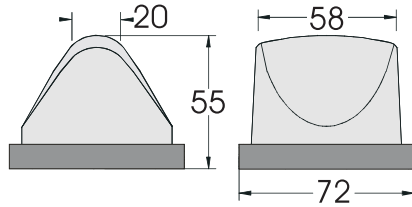
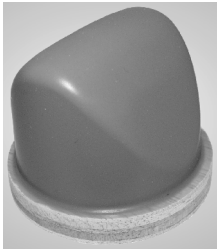

Nr. 517

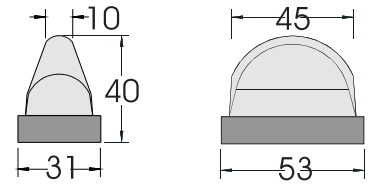
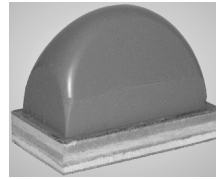

Nr. 16

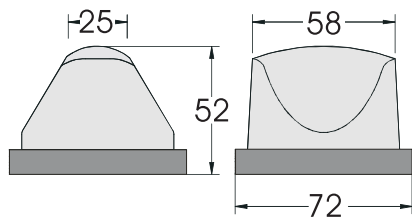

Nr. 772

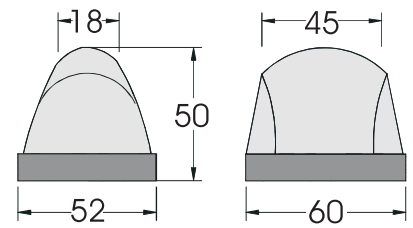
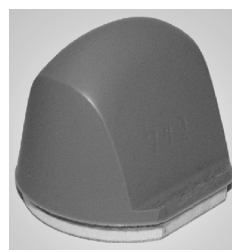

Nr. 15

Nr. 15K H 48

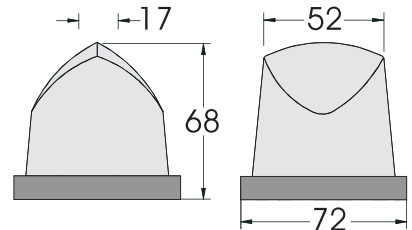

Nr. 49

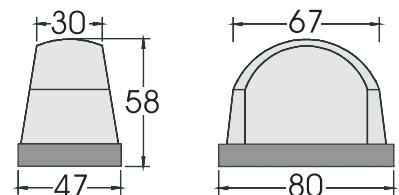
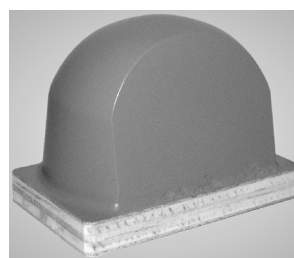

Nr. 14

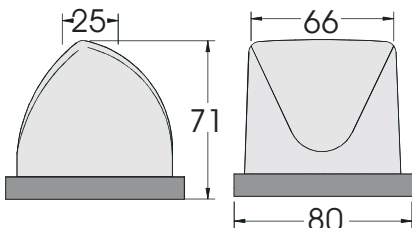

Nr. 774

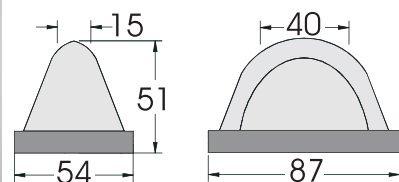
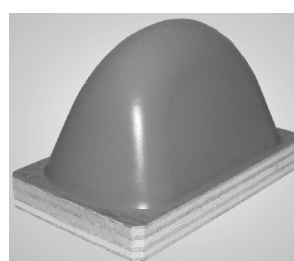

Nr. 17

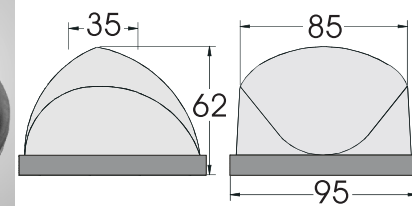

Nr. 773

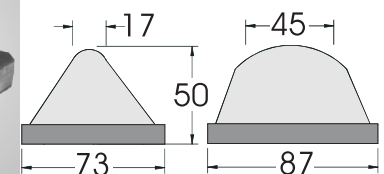
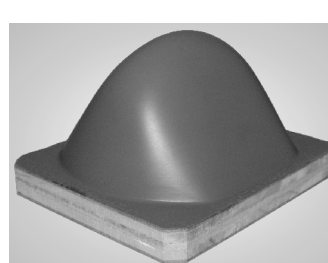



# LÜCK® TAMPON

H = Höhe  
L = Länge  
B = Breite  
SL = Silikonlänge

Nr. 775

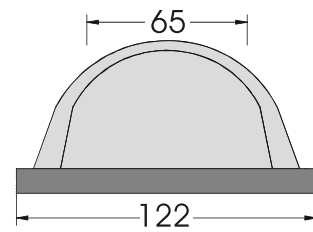
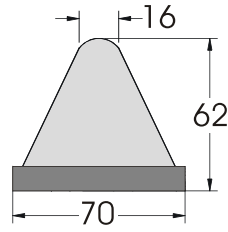
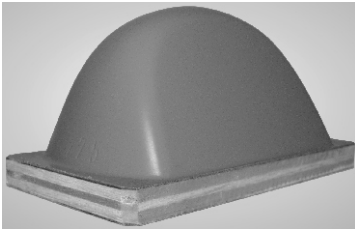

Nr. 777

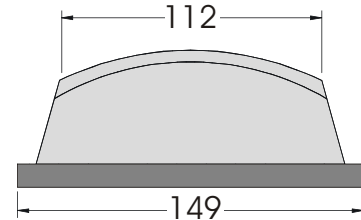
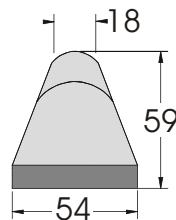
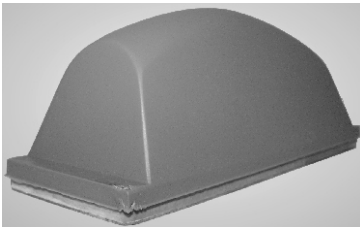

Nr. 776

Nr. 776K L 105 SL 70

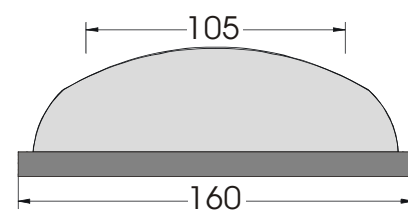
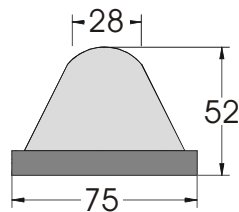
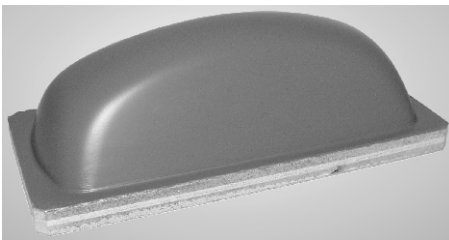

Nr. 1610

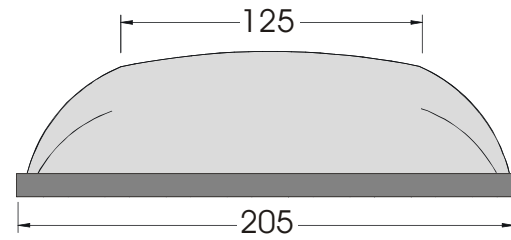
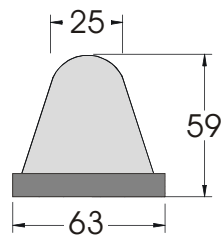
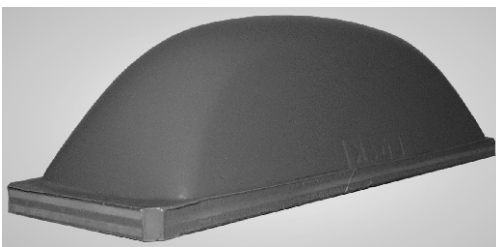

Nr. 778

Nr. 778K L 178 SL 168

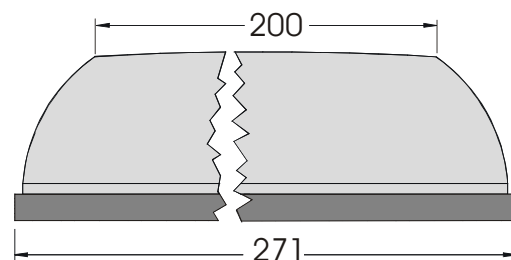
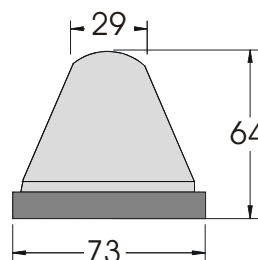
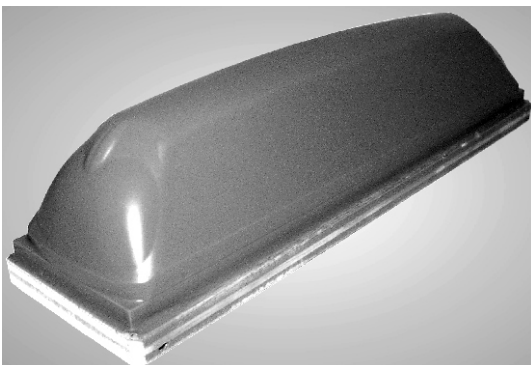

H = height  
 L = length  
 B = width  
 SL = silicone length

**LÜCK®**  
**TAMPON**



**Nr. 779**

Nr. 779K L 190 SL 178 B 51

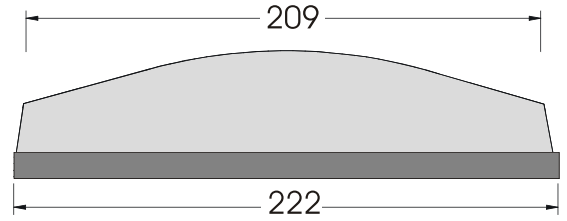
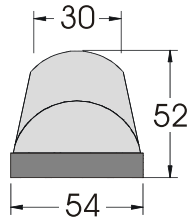
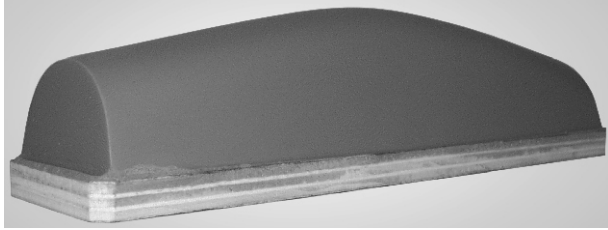

**Nr. 780**

Nr. 780K L 235 SL 200 B 60 H 52

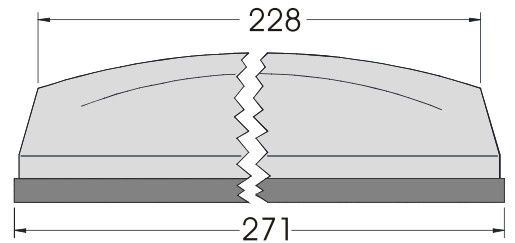
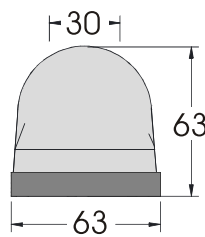
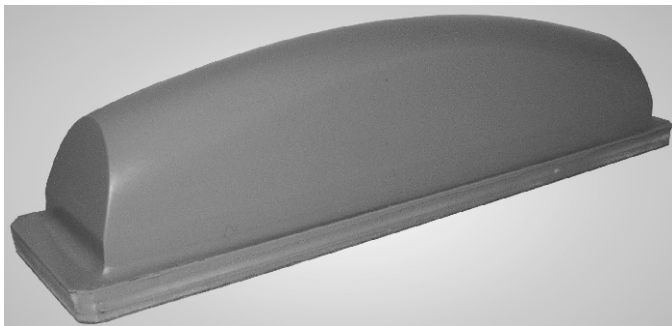

**Nr. 781**

Nr. 781WS L 320 B 55 H 61

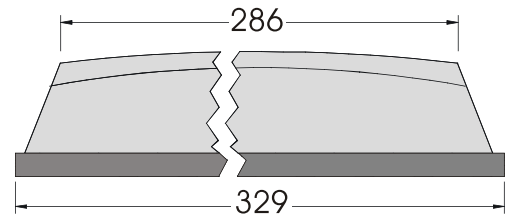
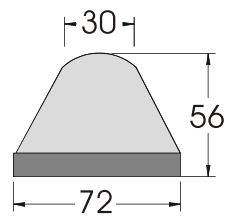
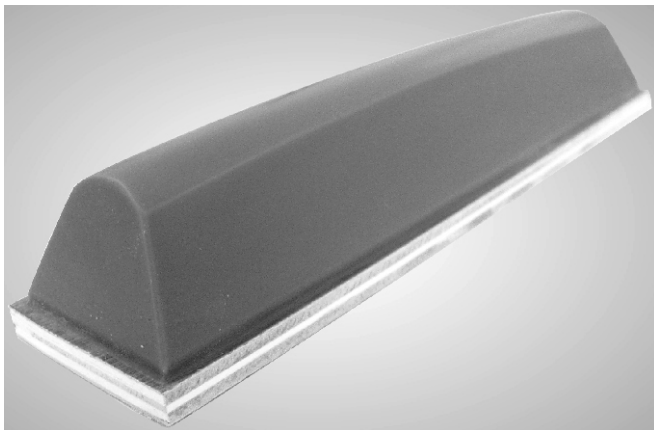

**Nr. 782**

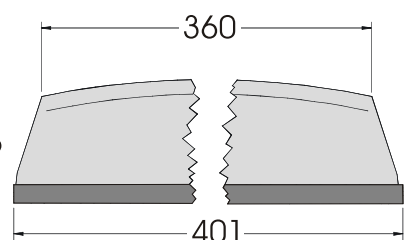
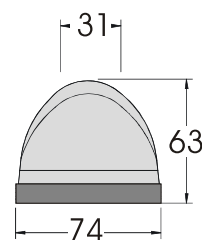
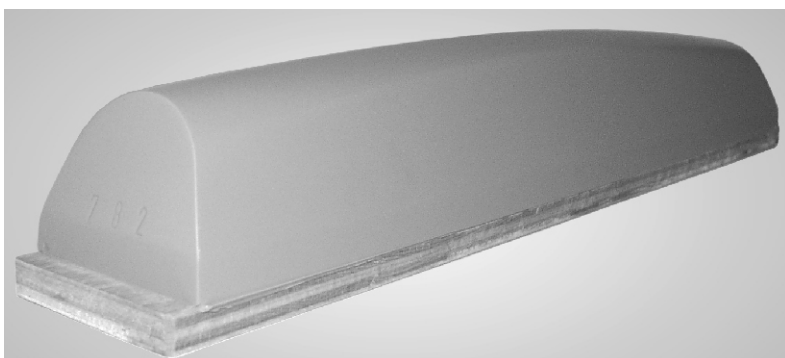



# LÜCK® TAMPON

H = Höhe  
B = Breite  
L = Länge  
SL = Silikonlänge  
SB = Silikonbreite

Nr. 914

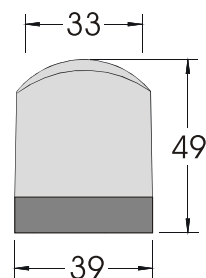
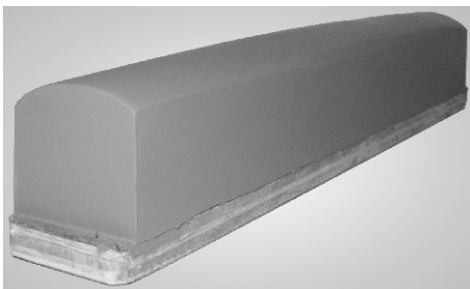

L 275 SL 260

Nr. 784

Nr. 784K B 71 H 54

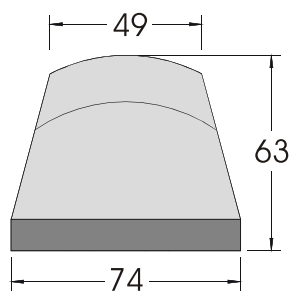
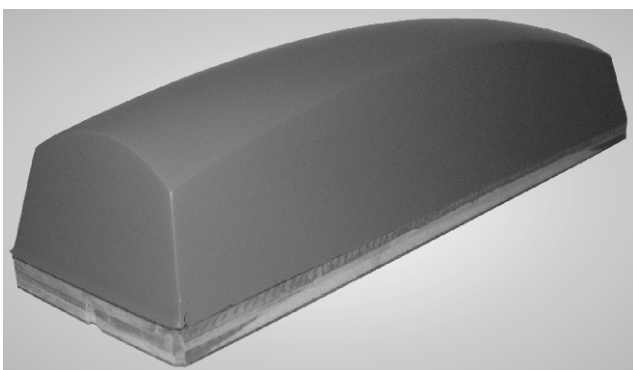

L 287 SL 269

Nr. 786

Nr. 786K L 193 SL 170

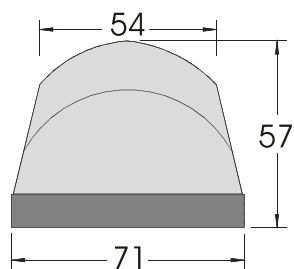
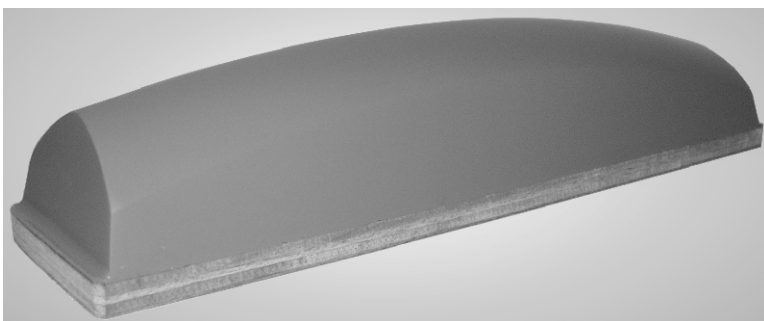

L 290 SL 270

Nr. 783

Nr. 783K L 173 SL 142

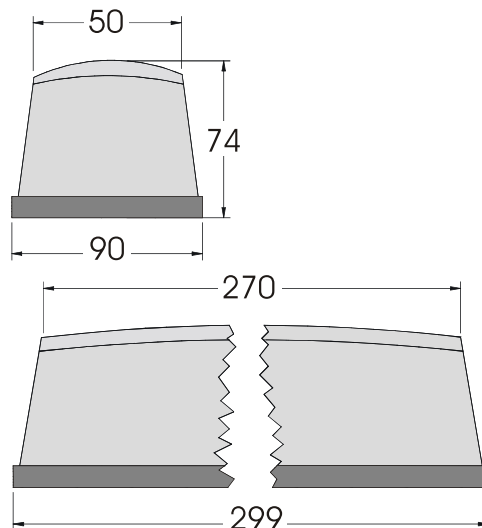
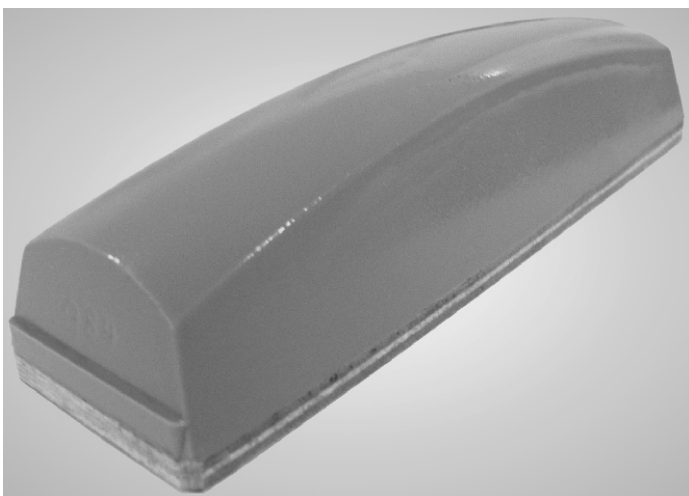

H = height  
 B = width  
 L = length  
 SL = silicone length  
 SB = silicone width

**LÜCK®**  
**TAMPON**



**Nr. 193**

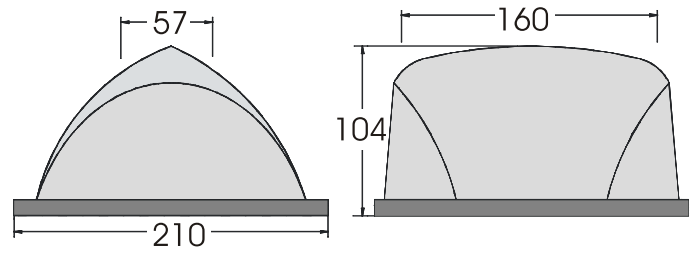
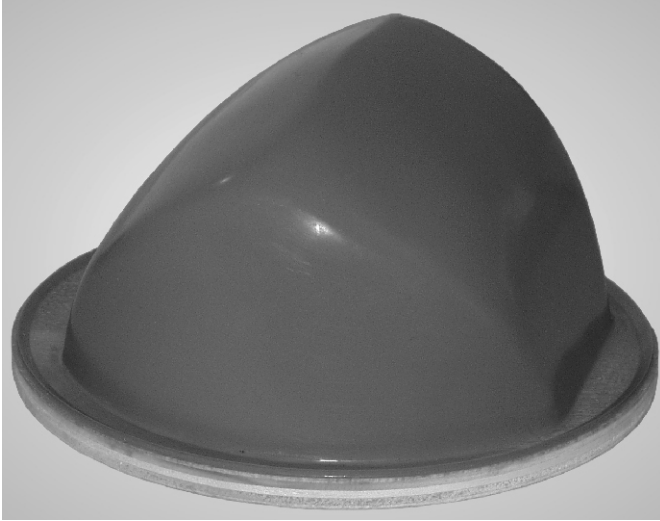

**Nr. 769**

Nr. 769K H 59  
 Nr. 770 SB 35

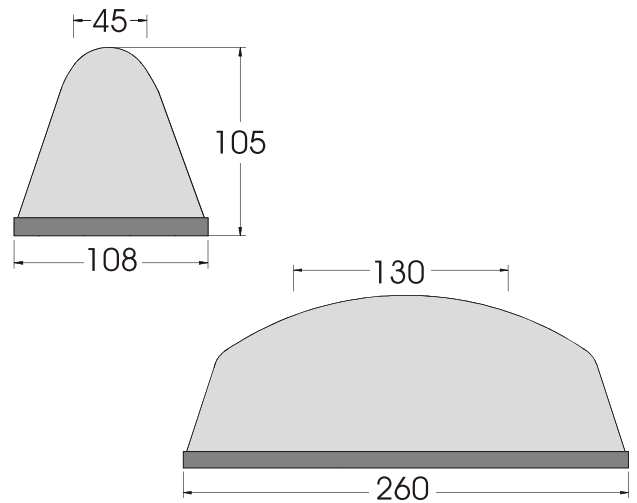
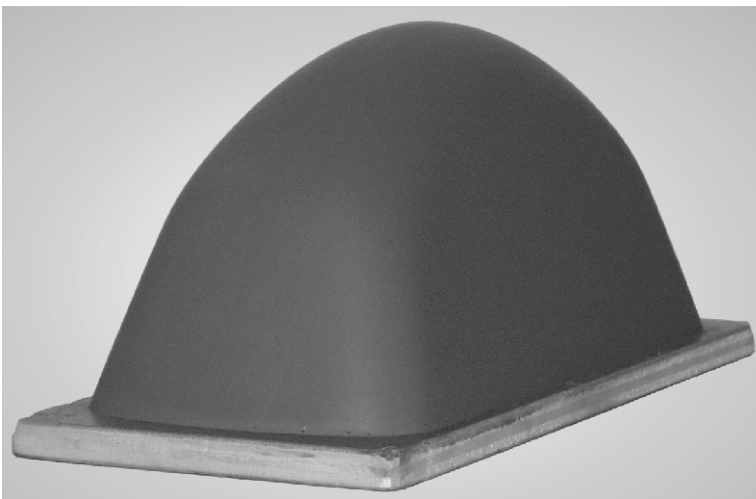

**Nr. 191**

Nr. 192 SB 80

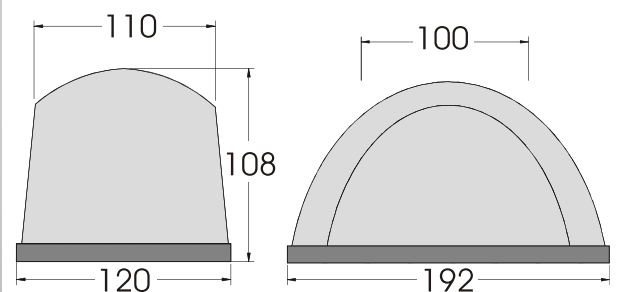
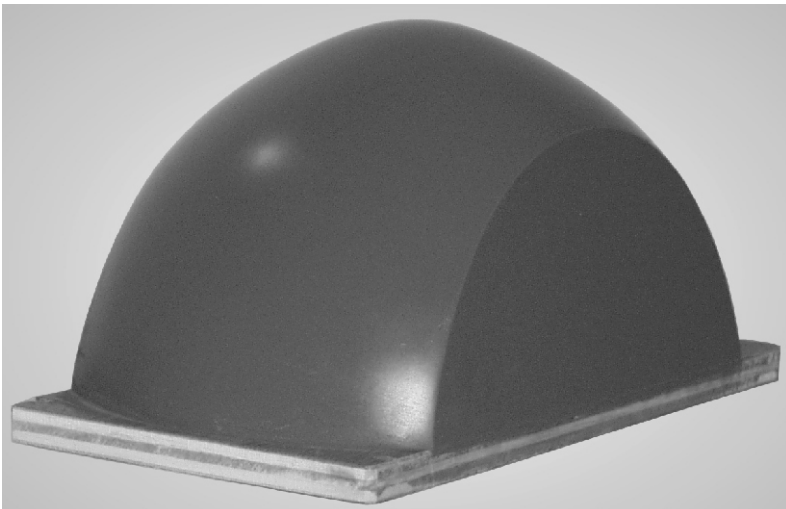

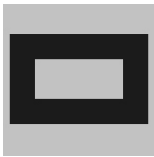

# LÜCK<sup>®</sup>

## TAMPON

H = Höhe  
L = Länge  
SL = Silikonlänge  
SB = Silikonbreite

Nr. 374 Alu M6

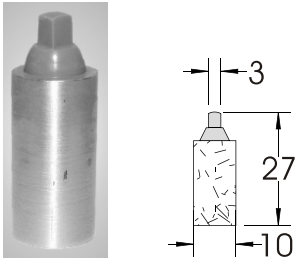

Nr. 10 Alu M3

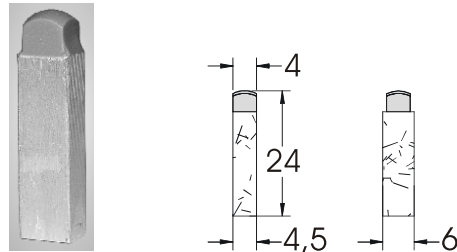

Nr. 2027 Alu M4

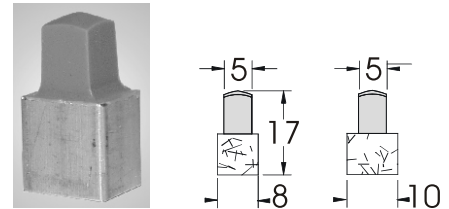

Nr. 373 Alu M6

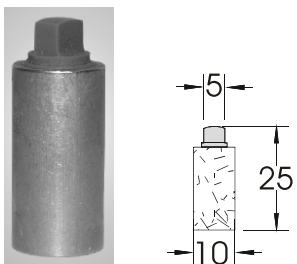

Nr. 2002

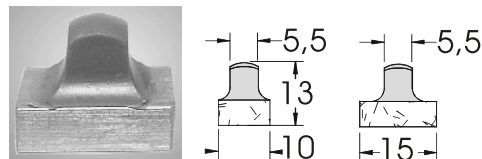

Nr. 2006 Alu M5

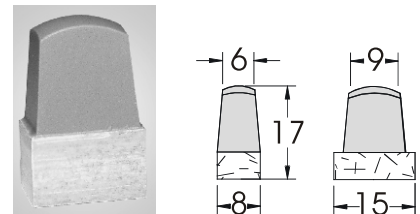

Nr. 2006M Alu M6

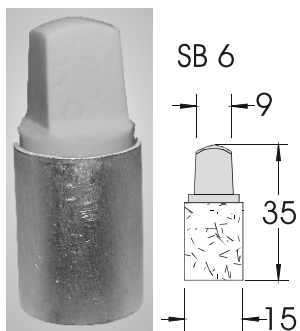

Nr. 2008M Alu M6

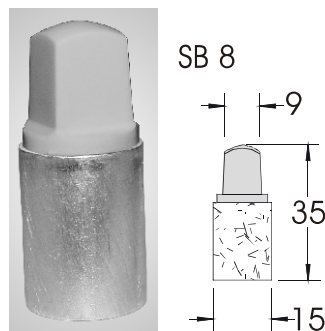

Nr. 2034 Alu M6

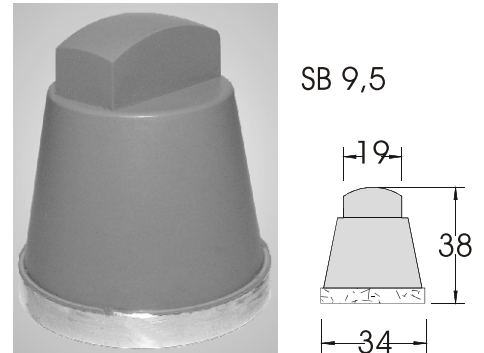

Nr. 2008 Alu M5

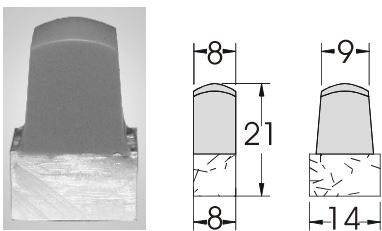

Nr. 11 Alu M5

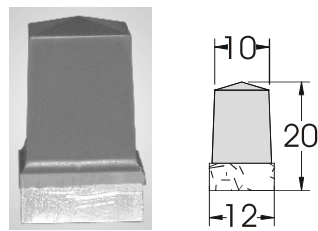

Nr. 2015 Alu M5

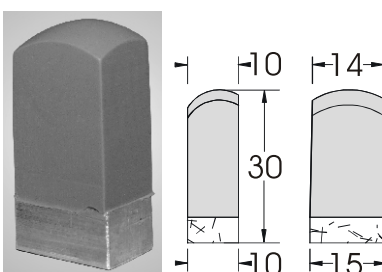

Nr. 2003 Alu M6

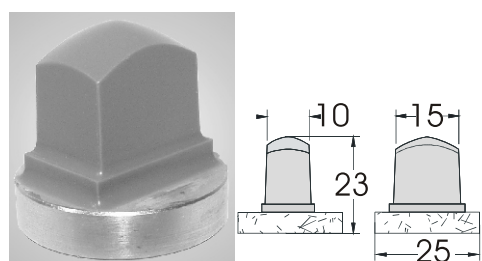

Nr. 2014 Alu M6

Nr. 2013 Alu M6 H 21

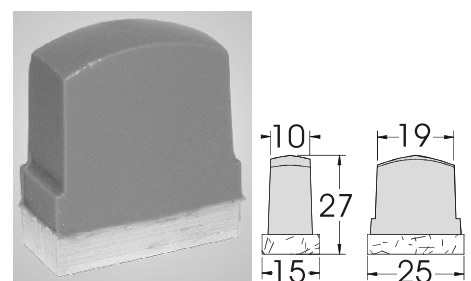

H = height  
 L = length  
 SL = silicone length  
 SB = silicone width

# LÜCK® TAMPON

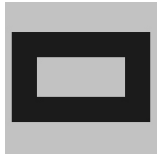

## Nr. 393/30 Alu M6

Nr. 393 L 44 SL 33 H 37  
 Nr. 393 Alu M6 L 44 SL 33  
 Nr. 393/25 Alu M6 L 36 SL 25



B 17 SB 10

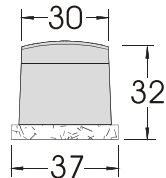

## Nr. 9 Alu M5

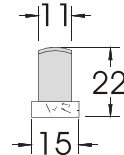
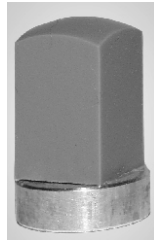

## Nr. 519

Nr. 519 Alu M6 H 34

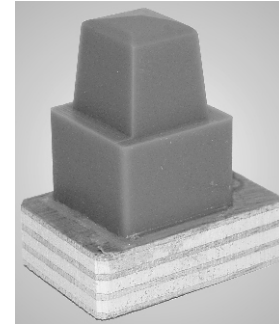

B 25 SB 13

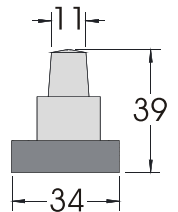

## Nr. 2024 Alu M5

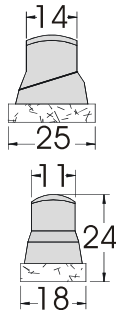
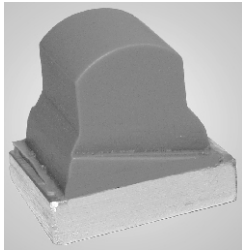

## Nr. 2022 Alu M5

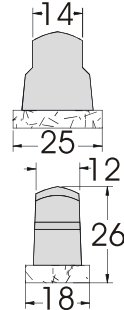
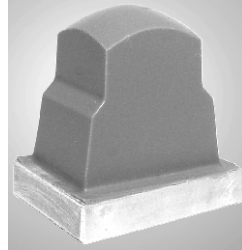

## Nr. 619

Nr. 619 Alu M6 H 21

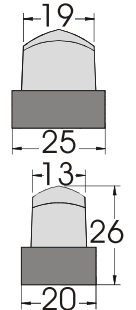
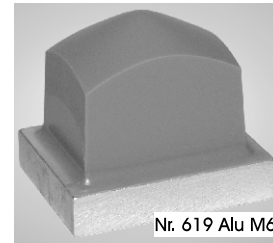

## Nr. 394

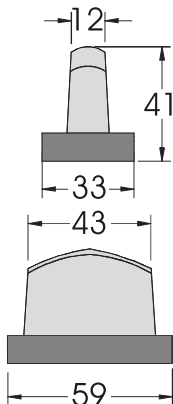
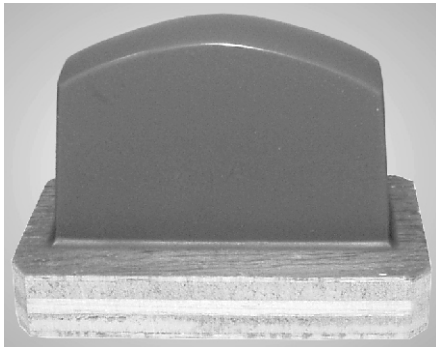

## Nr. 494

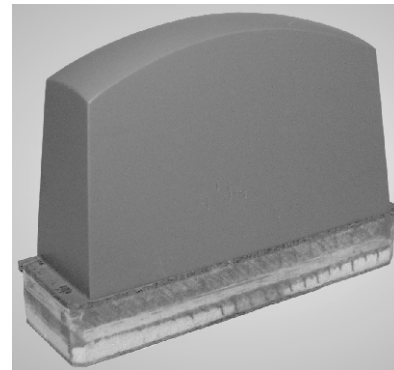

B 18 SB 12

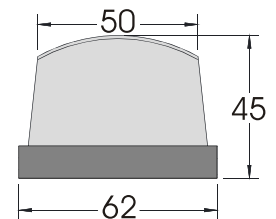

## Nr. 309

Nr. 309 Alu M6 H 41  
 Nr. 307 H 54

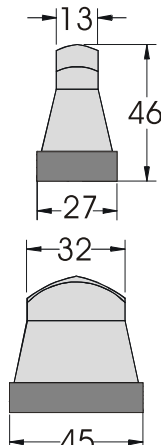
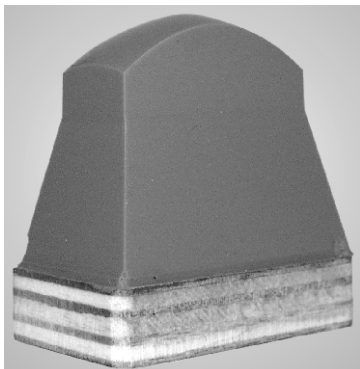

## Nr. 518

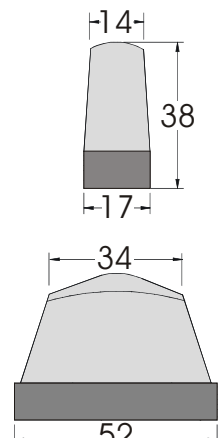
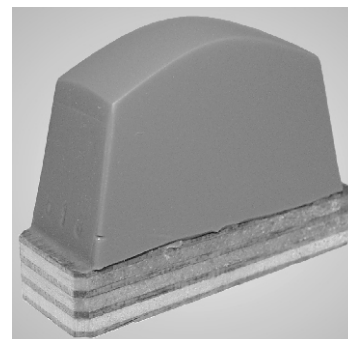

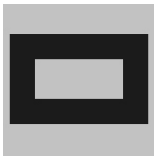

# LÜCK® TAMPON

H = Höhe  
B = Breite  
L = Länge  
SB = Silikonbreite

## Nr. 19

Nr. 19 Alu M6 H 25

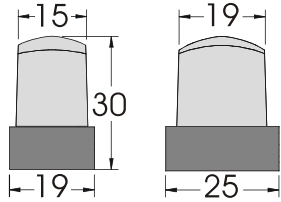

## Nr. 391

Nr. 391 Alu M6 H 26

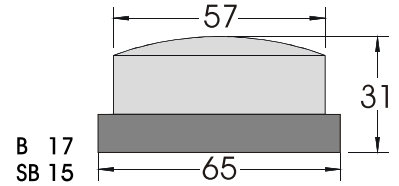
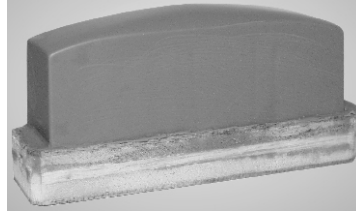

## Nr. 195

Nr. 195 Alu M6 H 27

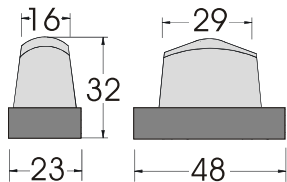
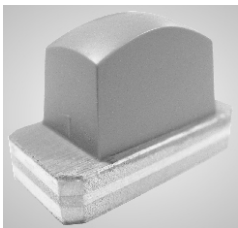

## Nr. 308

Nr. 308 Alu M6 H 35

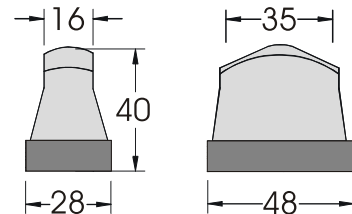
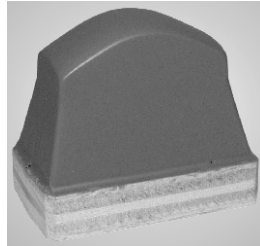

## Nr. 2039

Nr. 2039 Alu M6 H 36

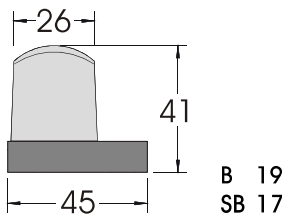

## Nr. 541 Alu M6

Nr. 541 H 39

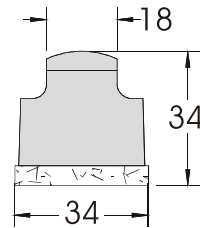

## Nr. 72

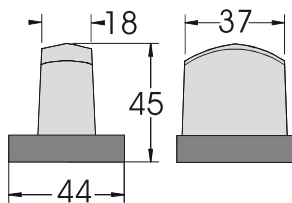
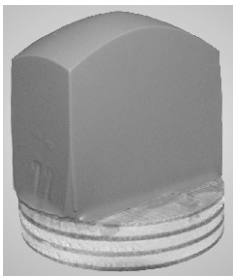

## Nr. 1006

Nr. 1006K L 66 B 30 H 45

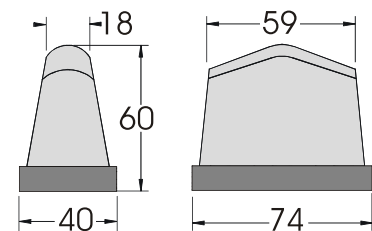
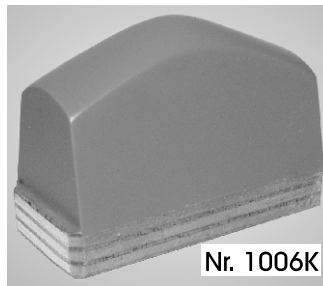

## Nr. 34

Nr. 34 Alu M6 H 36

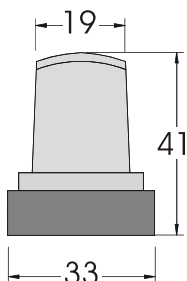
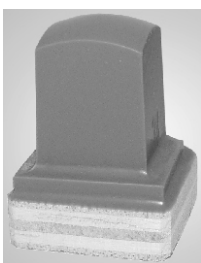

## Nr. 392

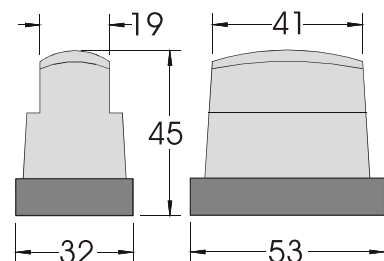
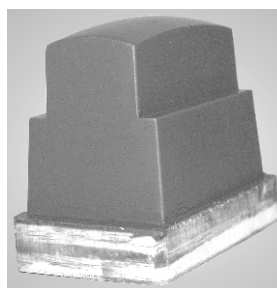



H = height  
 B = width  
 L = length  
 SB = silicone width

# LÜCK® TAMPON

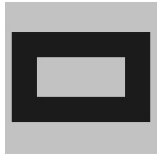

Nr. 395

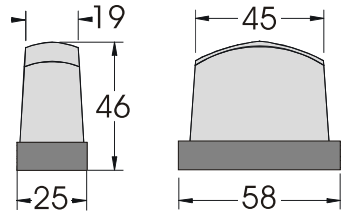
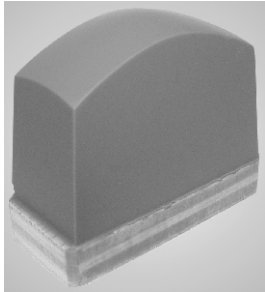

Nr. 758

Nr. 758 Alu M6 H 23

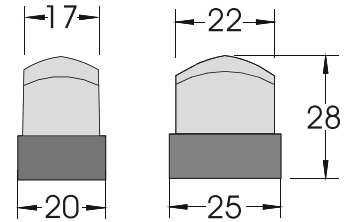
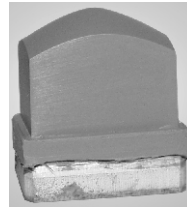

Nr. 521

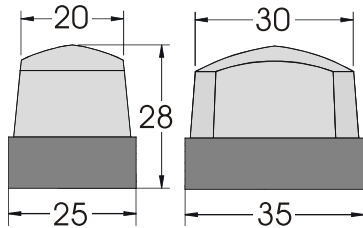
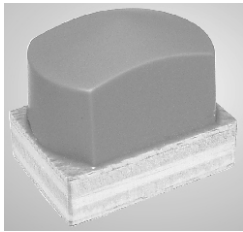

Nr. 820

Nr. 820 Alu M6 H 25

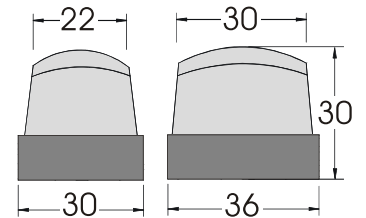
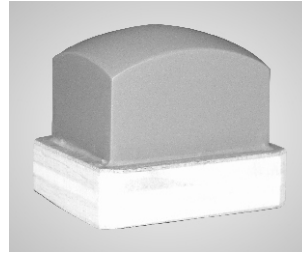

Nr. 71

Nr. 71K H 45

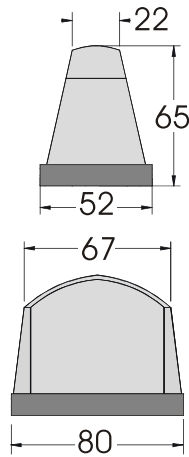
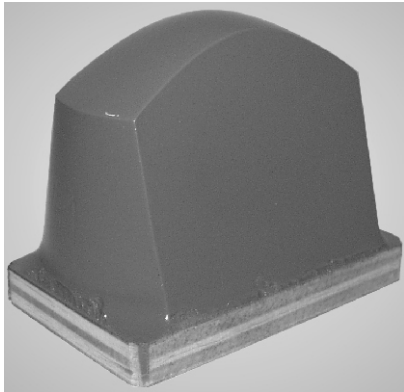

Nr. 768

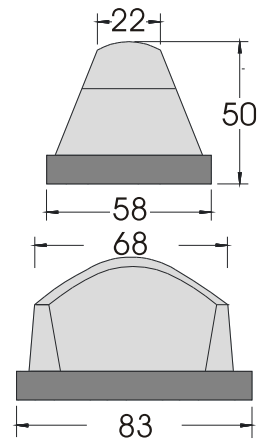
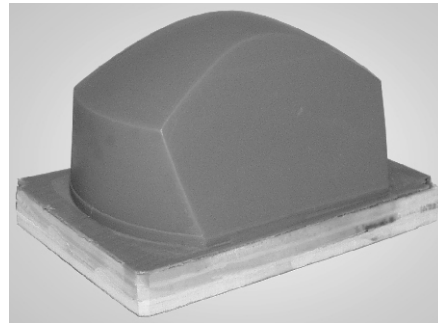

Nr. 196

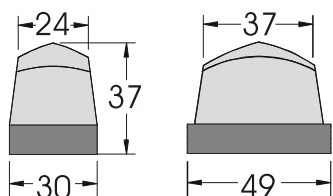
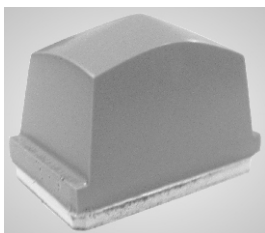

Nr. 424

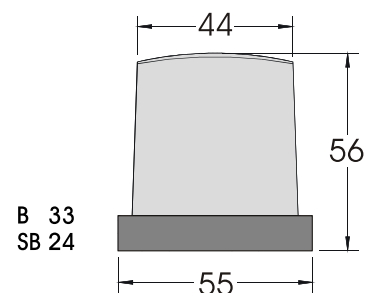
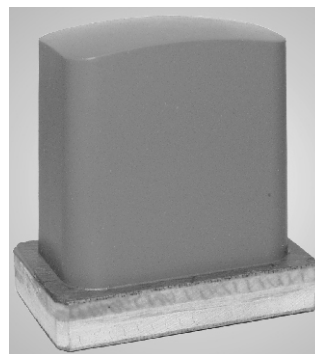

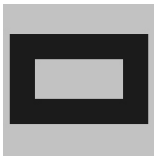

# LÜCK® TAMPON

H = Höhe  
B = Breite  
L = Länge  
SL = Silikonlänge  
SB = Silikonbreite

Nr. 396

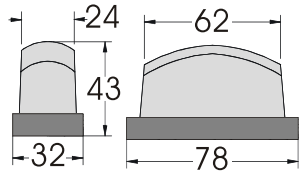
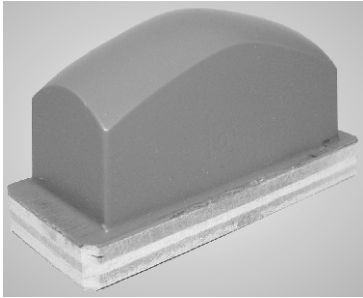

Nr. 624

Nr. 624 Alu M 6 H 35

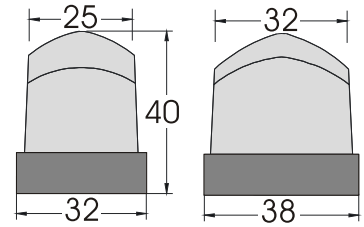
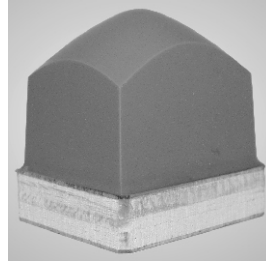

Nr. 24

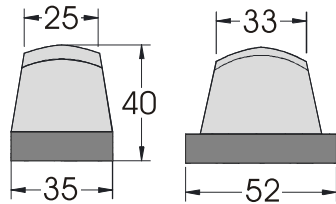
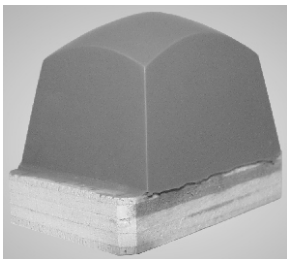

Nr. 853

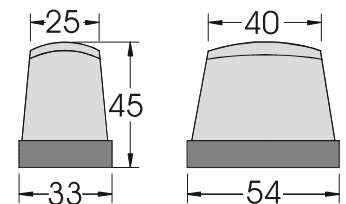
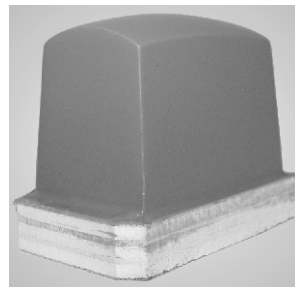

Nr. 509

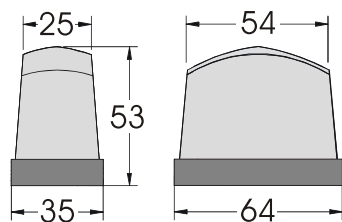
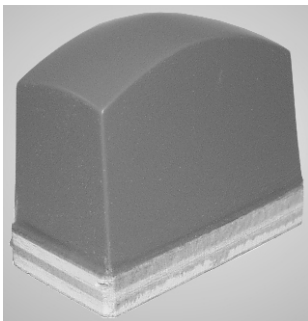

Nr. 423



B 34  
SB 25

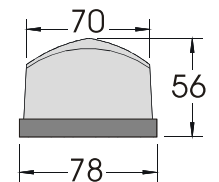

Nr. 855

Nr. 854 B 33 L 83 SL 69

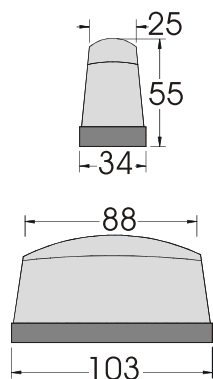
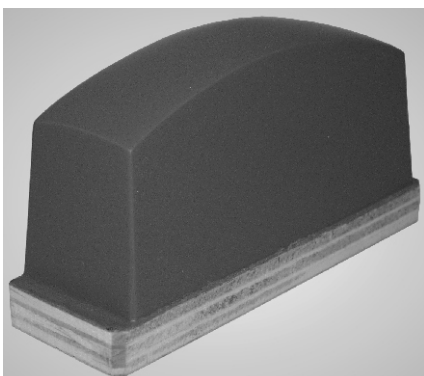

Nr. 33

Nr. 33 Alu M6 H 36

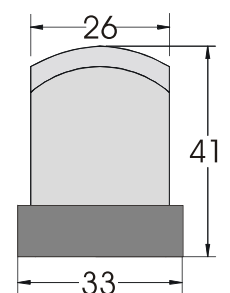

H = height  
 B = width  
 L = length  
 SL = silicone length  
 SB = silicone width

# LÜCK® TAMPON

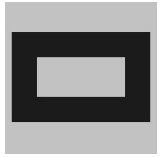

Nr. 852

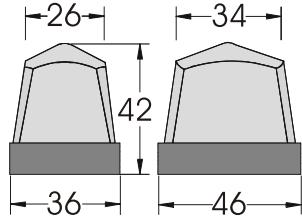
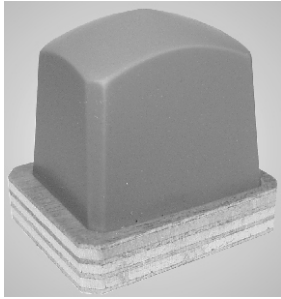

Nr. 533

Nr. 533 Alu M6 H 33

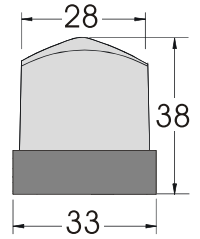
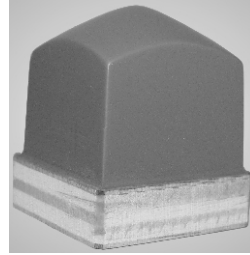

Nr. 91

Nr. 91K H 52 SL 48

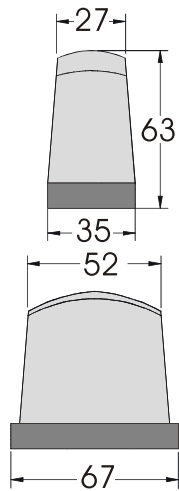
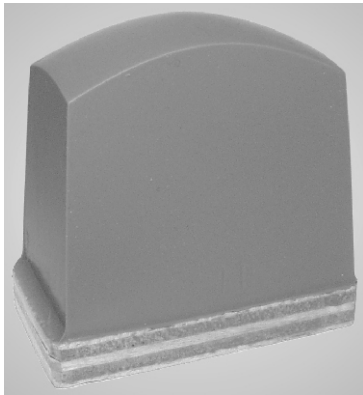

Nr. 85

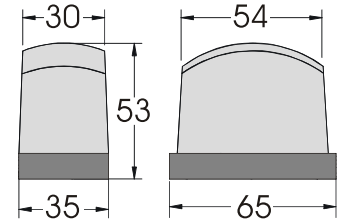
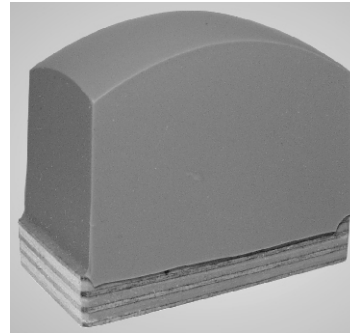

Nr. 49

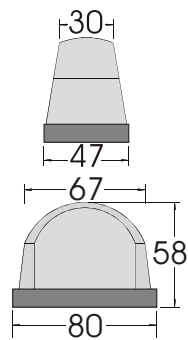
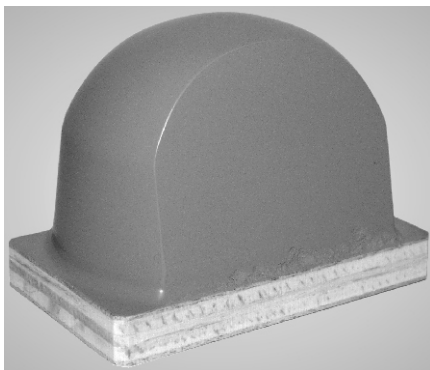

Nr. 1071

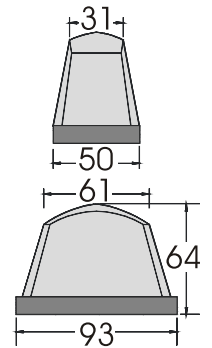
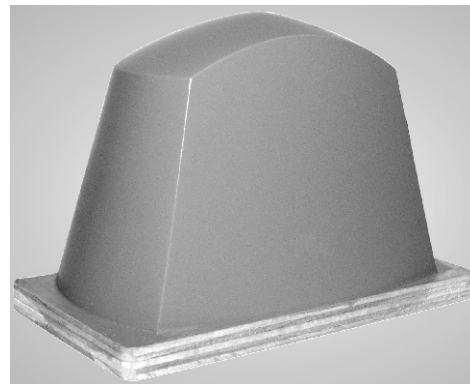

Nr. 422

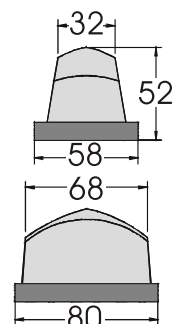
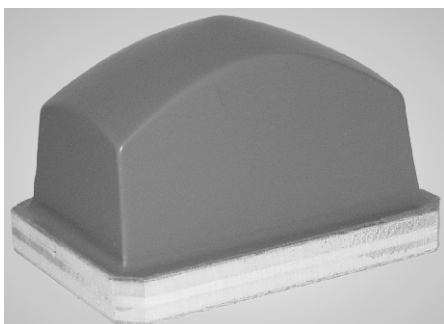

Nr.22

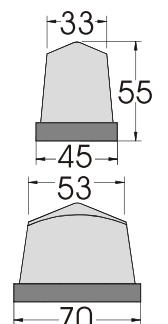
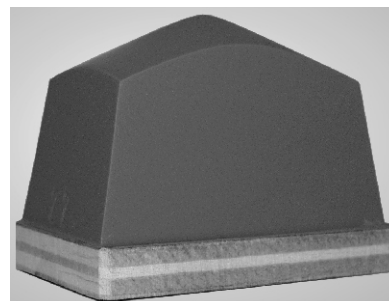

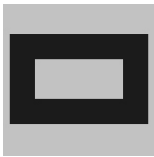

# LÜCK® TAMPON

H = Höhe  
 B = Breite  
 L = Länge  
 SL = Silikonlänge  
 SB = Silikonbreite

Nr. 386

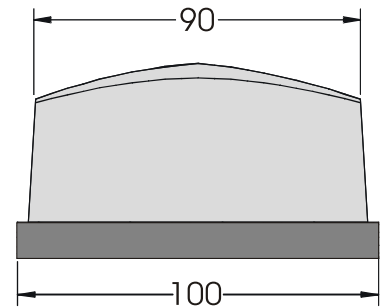
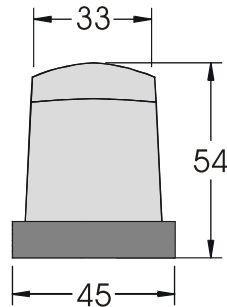
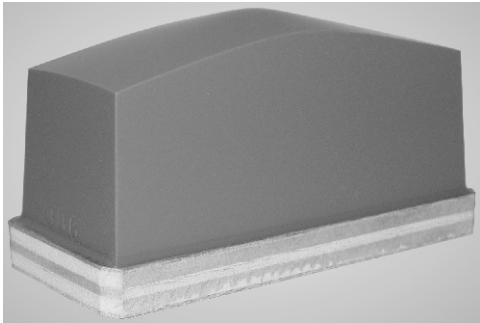

Nr. 532

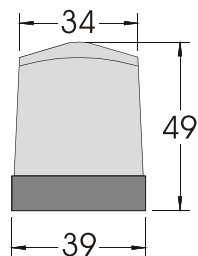
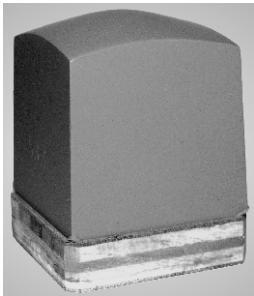

Nr. 93

Nr. 93K H 57

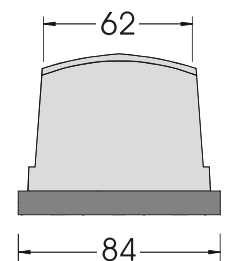
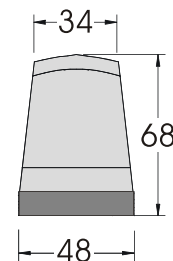
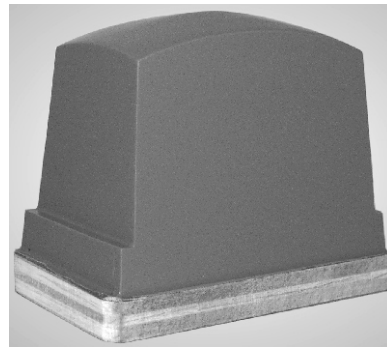

Nr. 92

Nr. 92 Alu M6 H 30

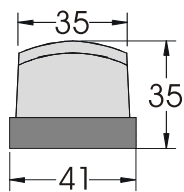
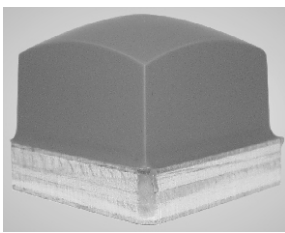

Nr. 430

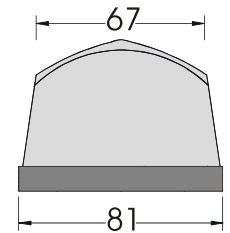
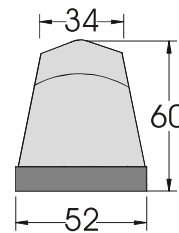
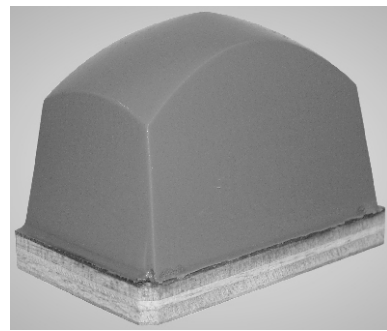

Nr. 23

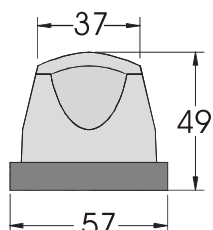
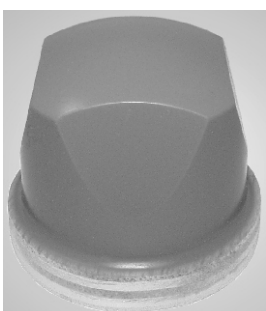

Nr. 90

Nr. 90K B 51 H 52

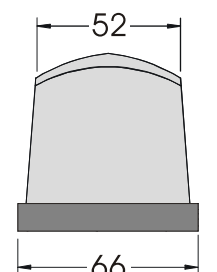
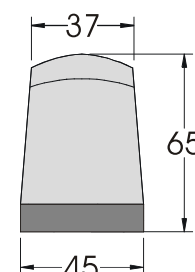
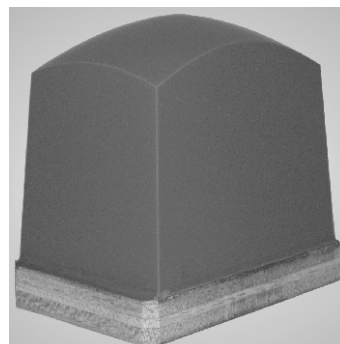

H = height  
 B = width  
 L = length  
 SL = silicone length  
 SB = silicone width

# LÜCK® TAMPON

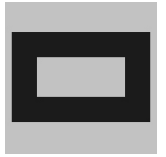

Nr. 95

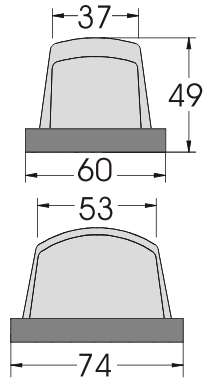
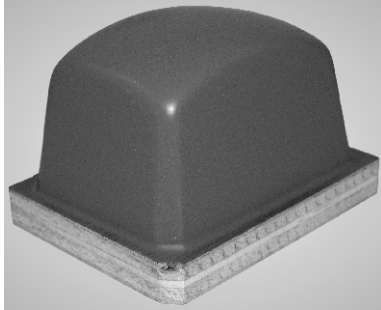

Nr. 427

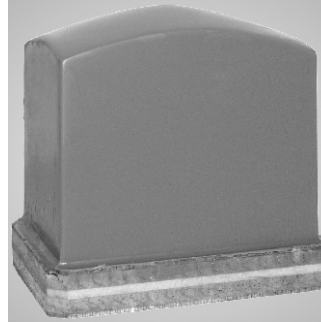

B 44  
SB 38

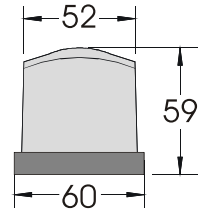

Nr. 89

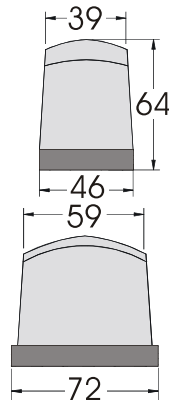
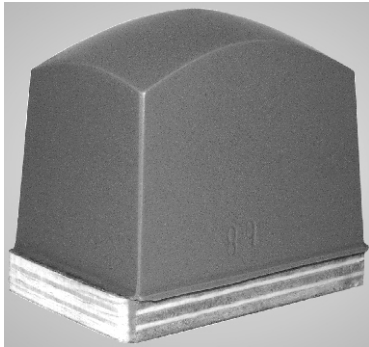

Nr. 771

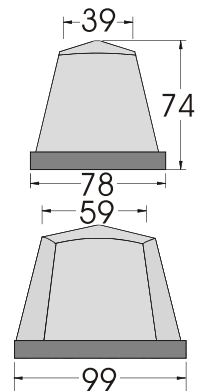
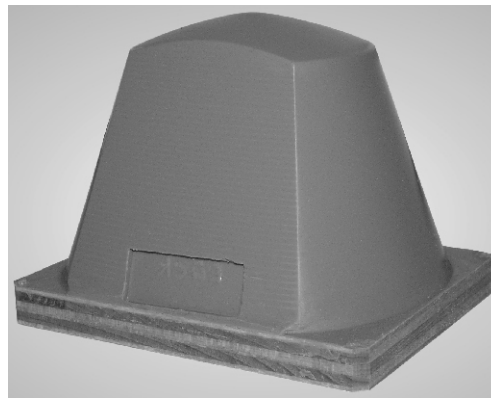

Nr. 534

Nr. 534 Alu M6 H 40

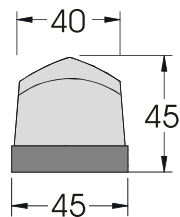
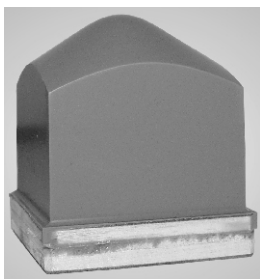

Nr. 560

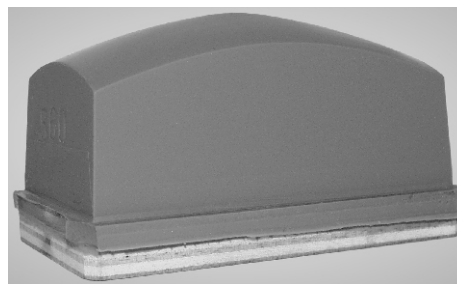

B 49  
SB 40

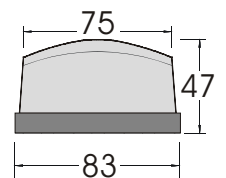

Nr. 561

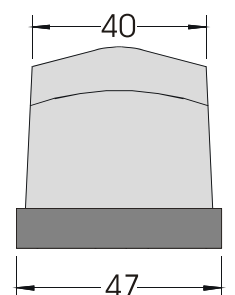
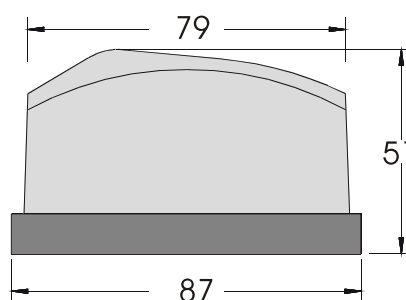
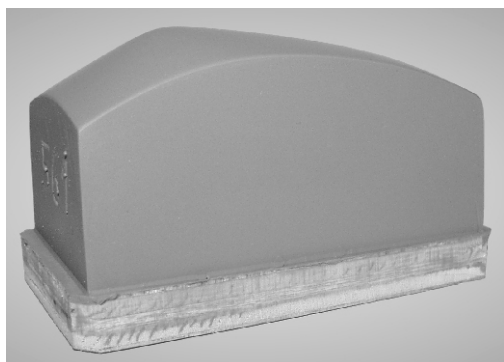

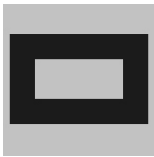

# LÜCK® TAMPON

H = Höhe  
SL = Silikonlänge

Nr. 565

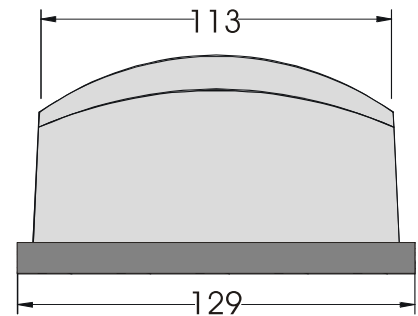
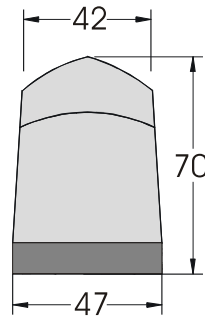
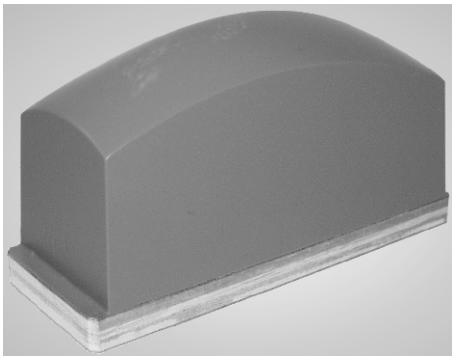

Nr. 566

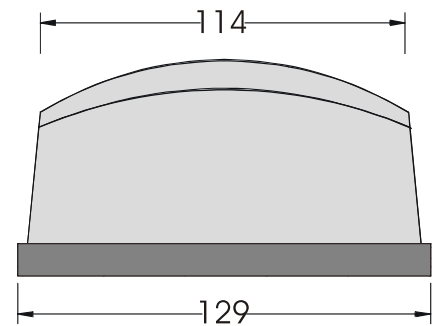
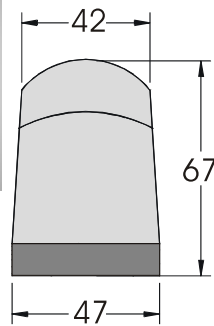
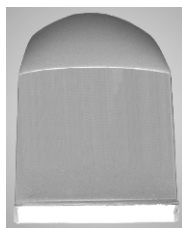
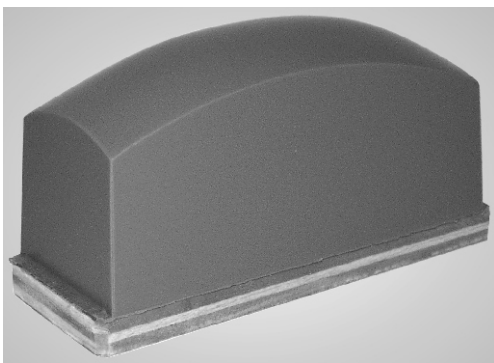

Nr. 94

Nr. 94K H 54

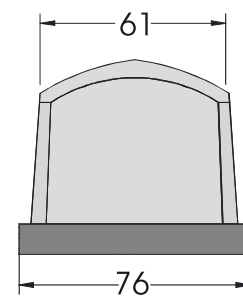
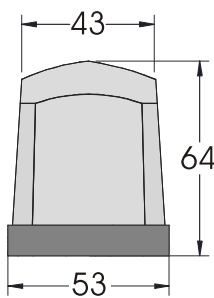
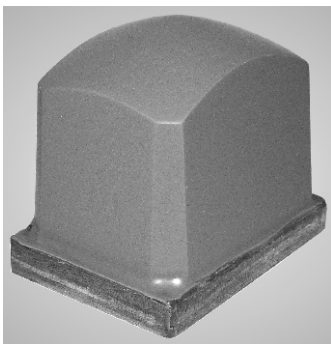

Nr. 765

Nr. 765K H 46 SL 113

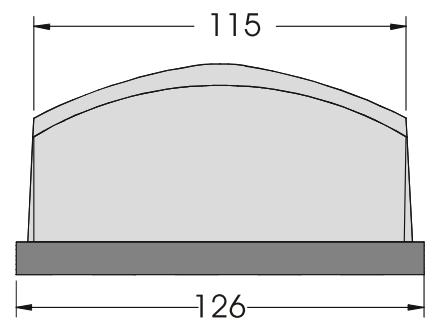
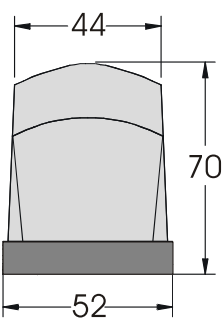
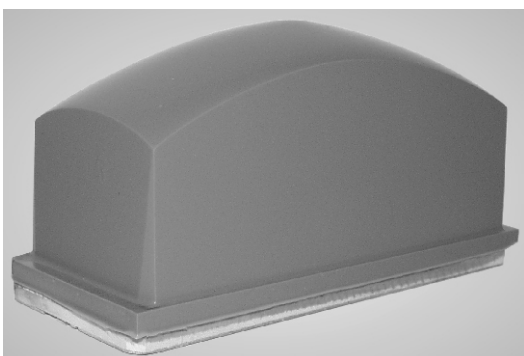

H = height  
SL = silicone length

# LÜCK® TAMPON



**Nr. 83**

Nr. 83K H48

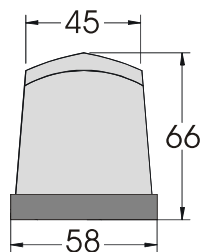
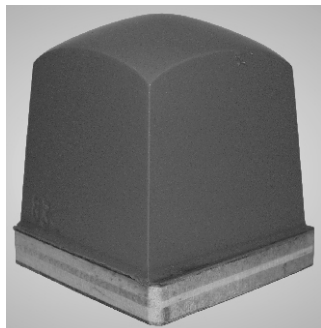

**Nr. 652**

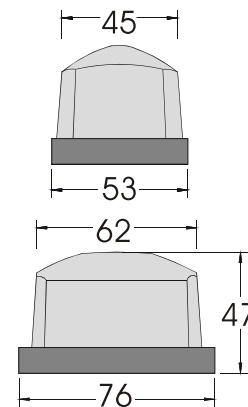
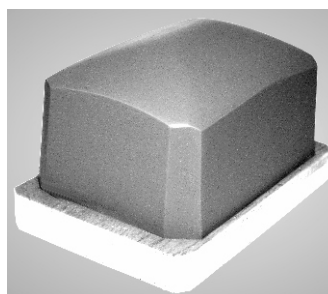

**Nr. 651**

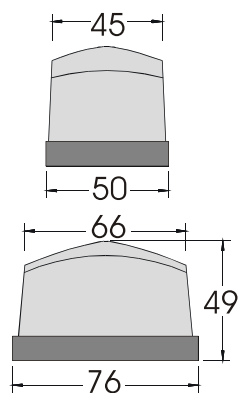
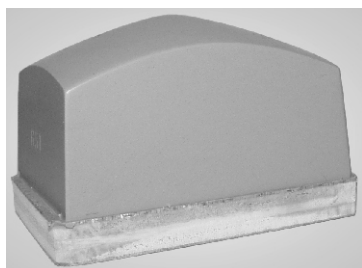

**Nr. 27**

Nr. 27K H 50

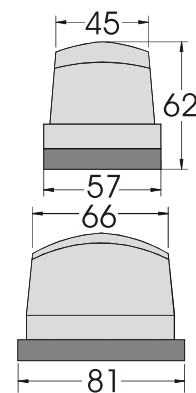
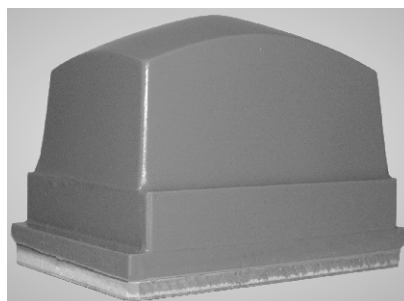

**Nr. 67**

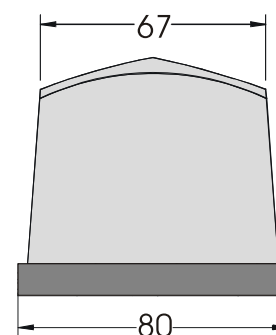
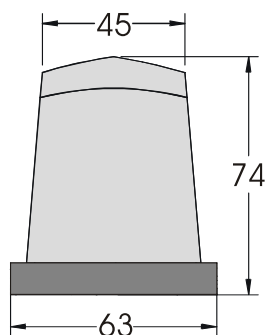
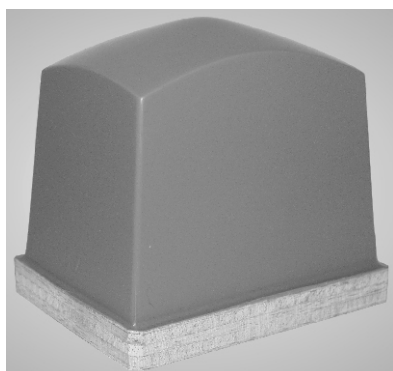

**Nr. 766**

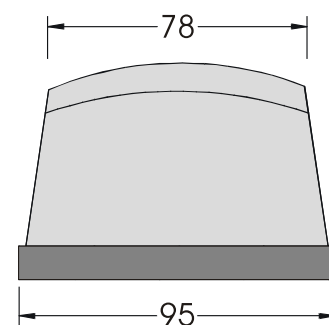
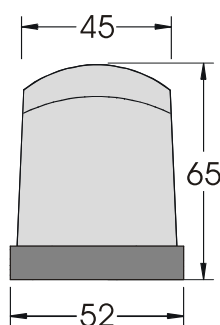
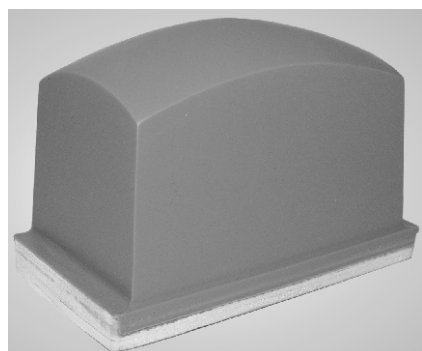

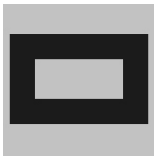

# LÜCK® TAMPON

H = Höhe  
B = Breite  
L = Länge  
SB = Silikonbreite

Nr. 30

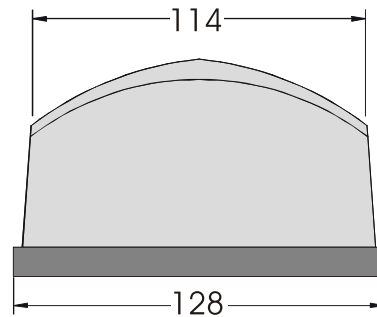
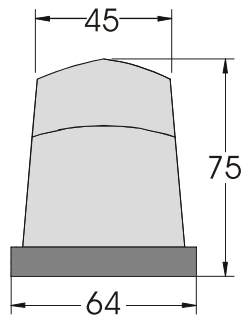
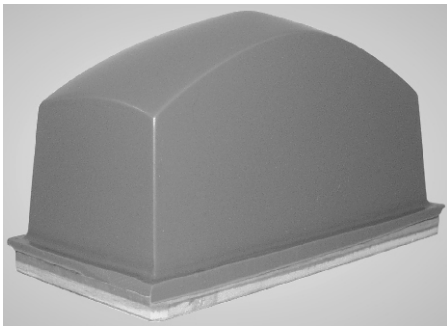

Nr. 402

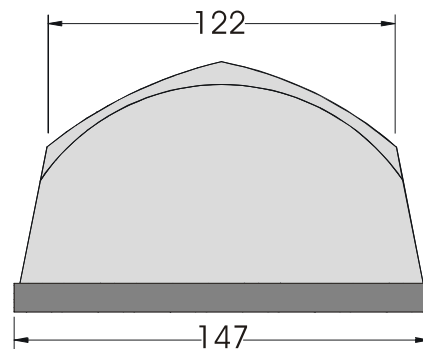
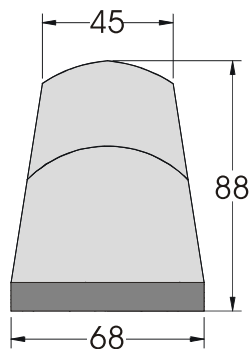
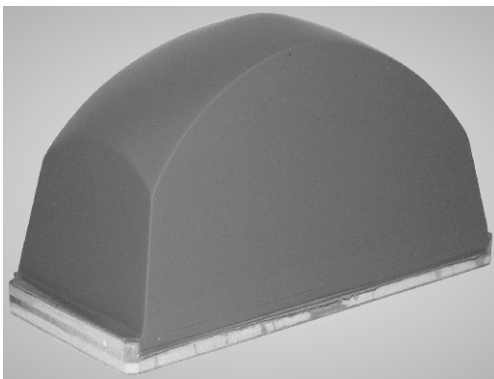

Nr. 345

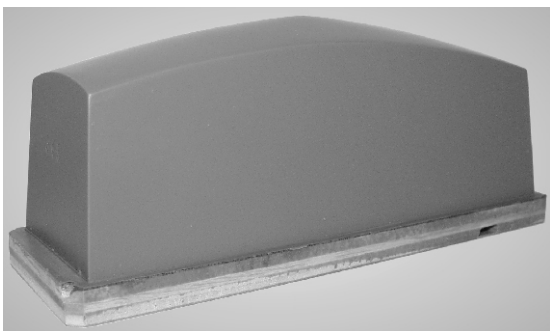

B 58  
SB 45

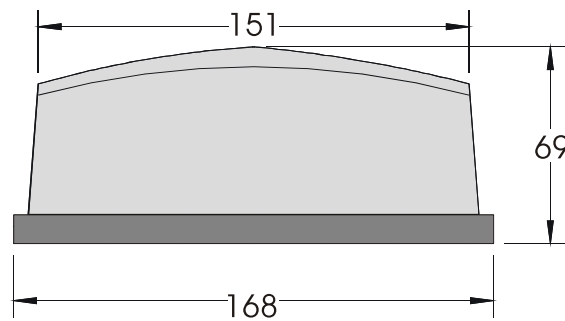

Nr. 344

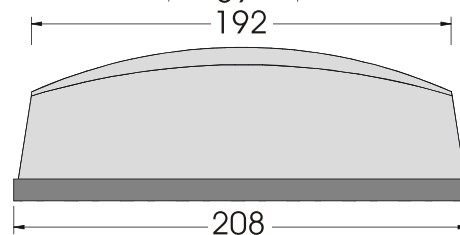
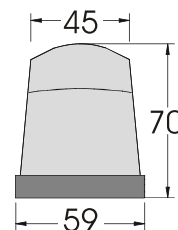
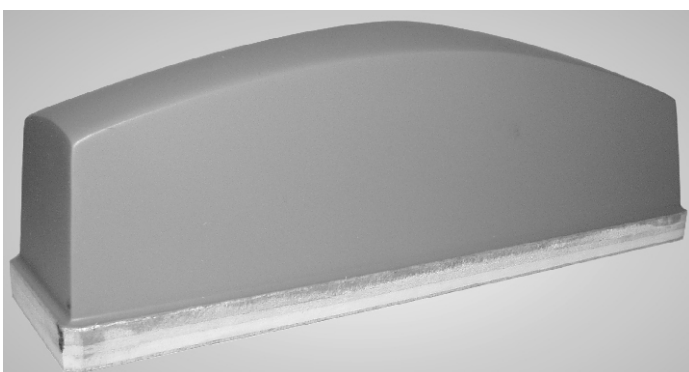



H = height  
 B = width  
 L = length  
 SB = silicone width

# LÜCK® TAMPON

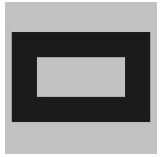

Nr. 86

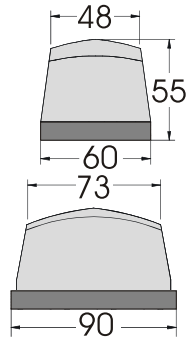
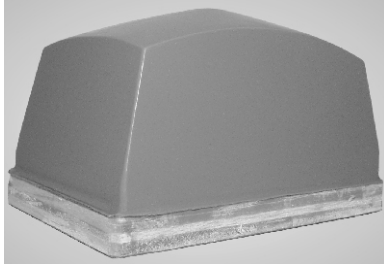

Nr. 710

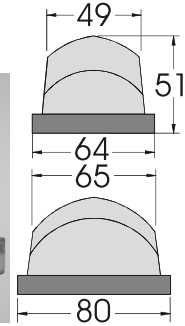
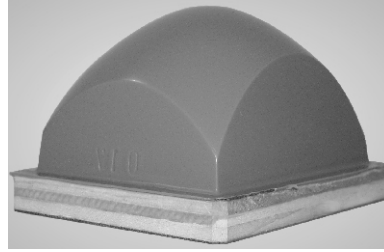

Nr. 341

Nr. 341K L 228 B 53 H 68

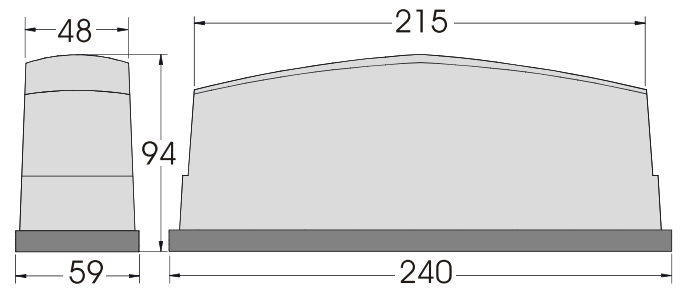
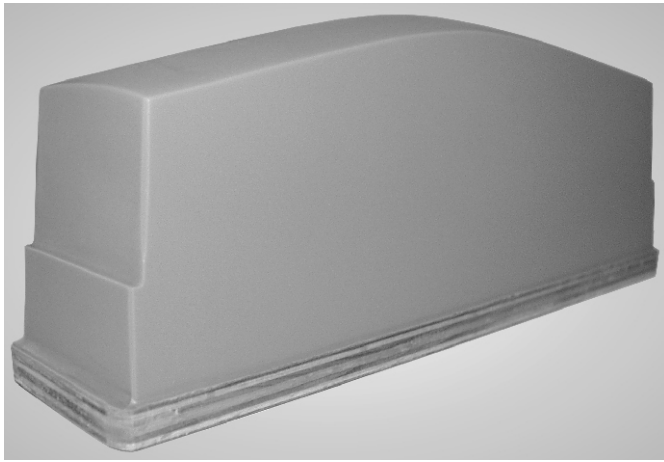

Nr. 785

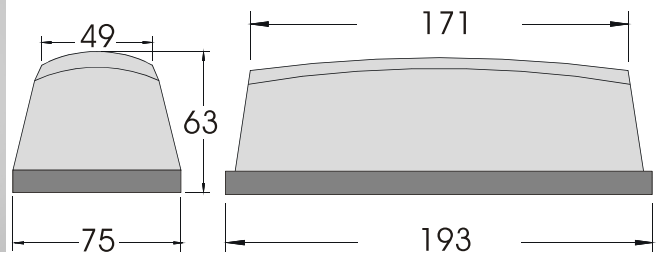
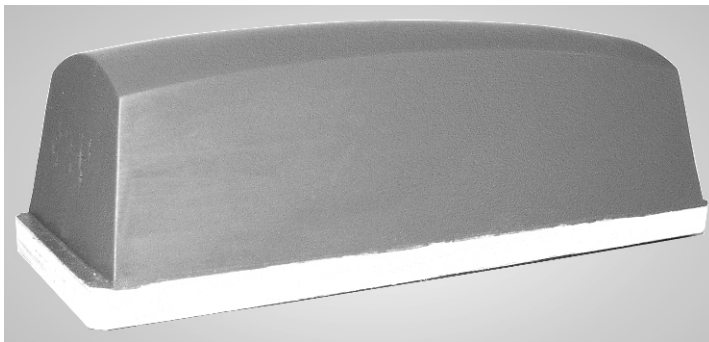

Nr. 340

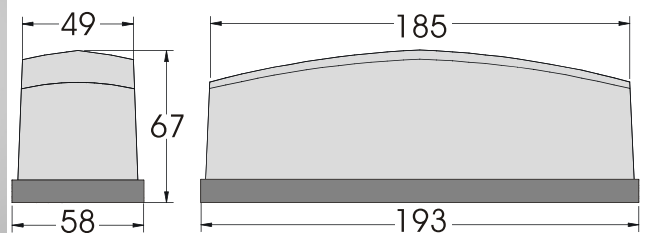
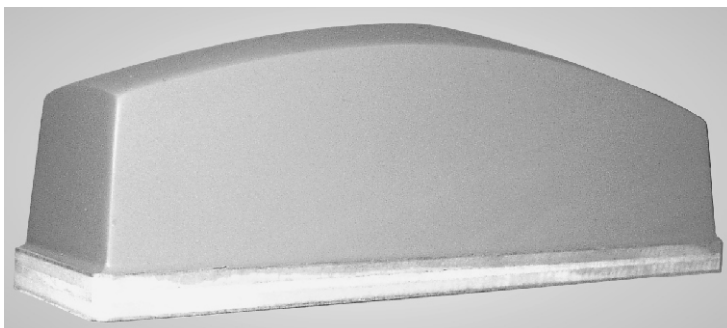

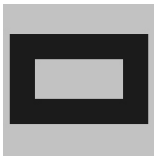

# LÜCK® TAMPON

H = Höhe  
B = Breite  
L = Länge  
SL = Silikonlänge  
SB = Silikonbreite

Nr. 81

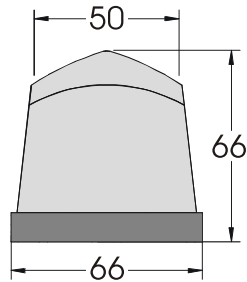
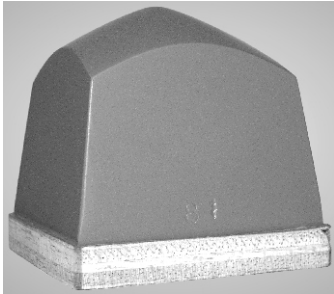

Nr. 504

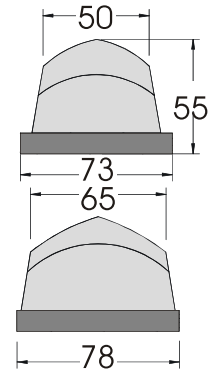
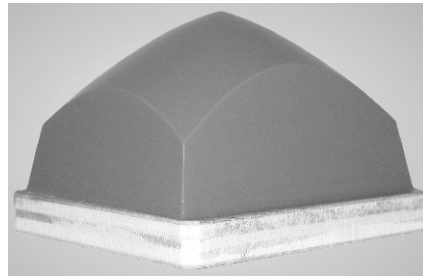

Nr. 972

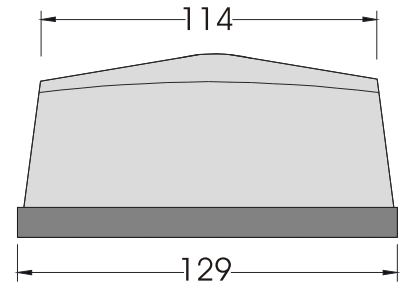
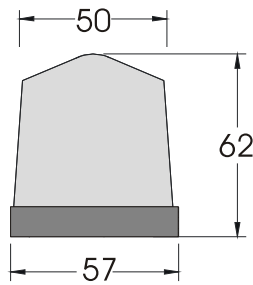
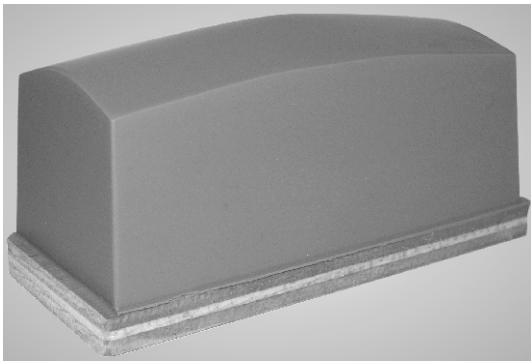

Nr. 798

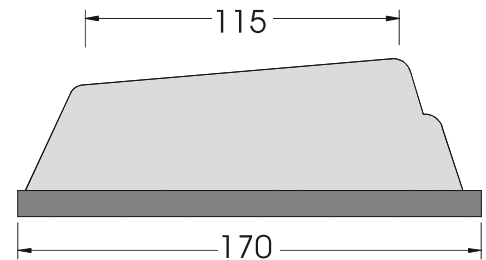
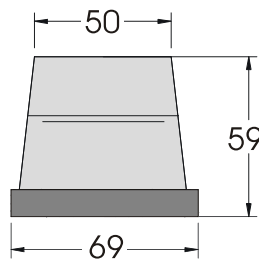
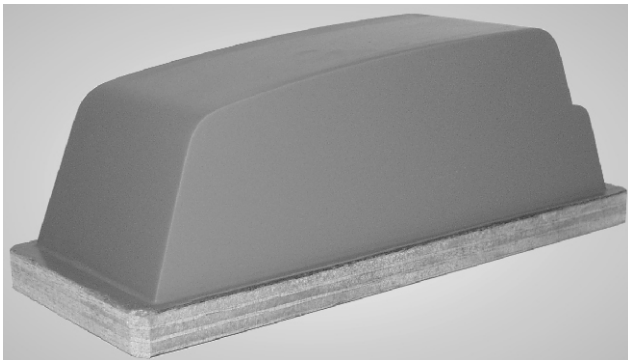

Nr. 797

Nr. 796 SB 40

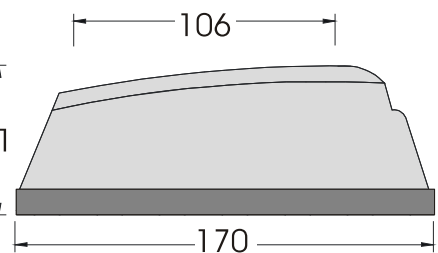
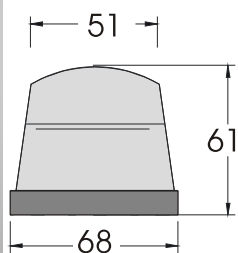
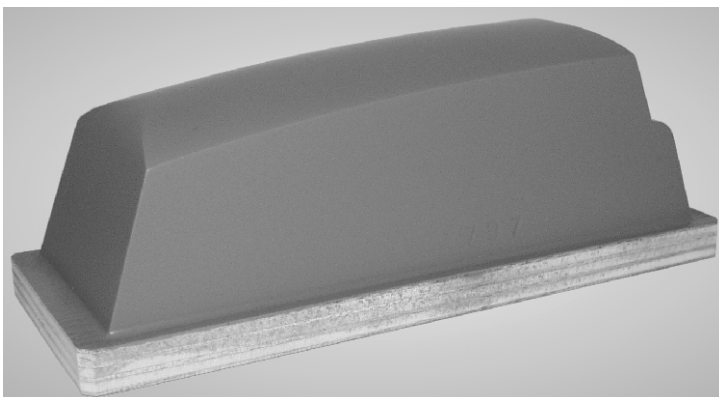

H = height  
 B = width  
 L = length  
 SL = silicone length  
 SB = silicone width

# LÜCK® TAMPON

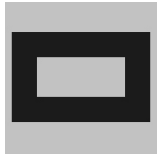

## Nr. 645

Nr. 277 H 60 L/B 56 SB/SL 47

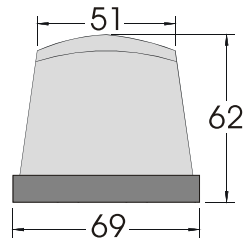
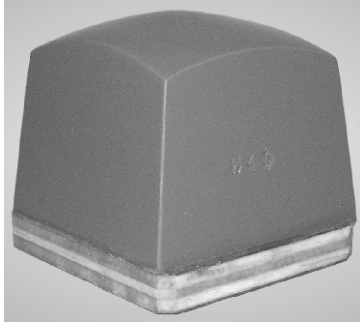

## Nr. 620

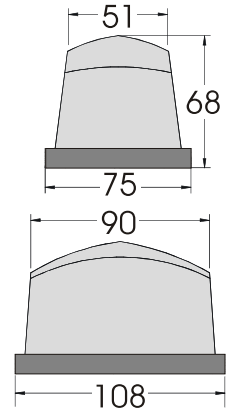
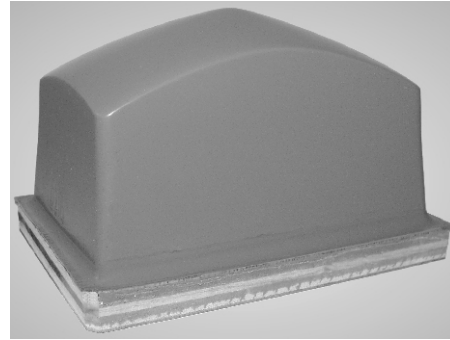

## Nr. 384

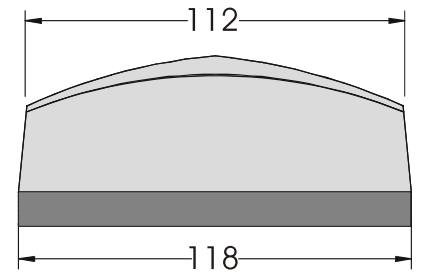
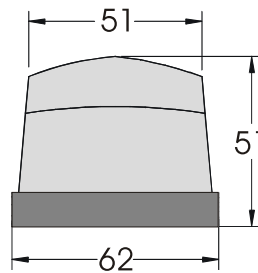
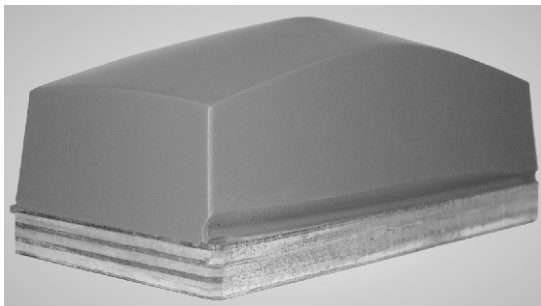

## Nr. 88

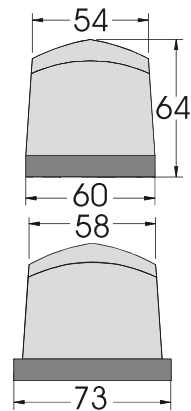
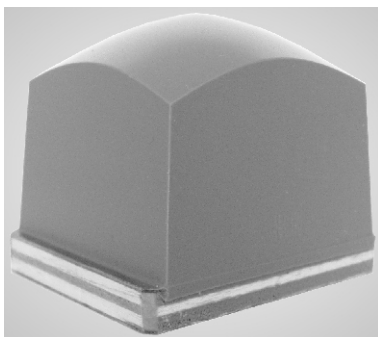

## Nr. 82

Nr. 82S SL 60 SB 60  
 Nr. 82S Alu M6 SL 60 SB 60 H 59

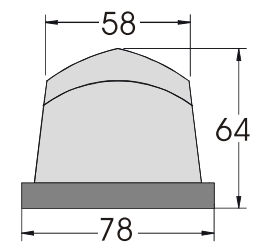
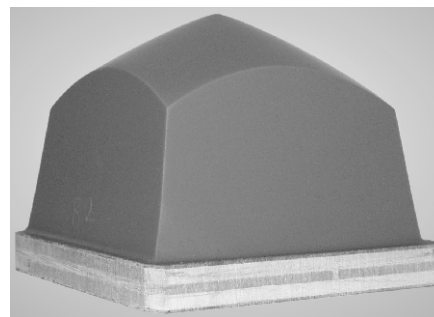

## Nr. 279

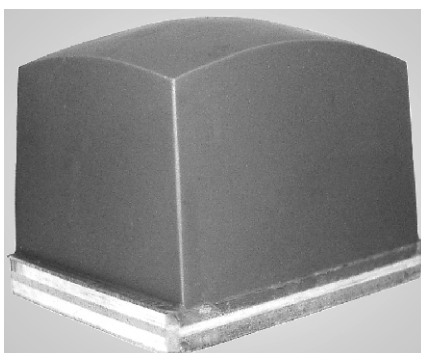

B 65  
 SB 57

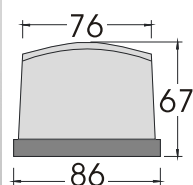

## Nr. 60

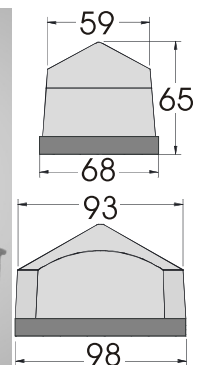
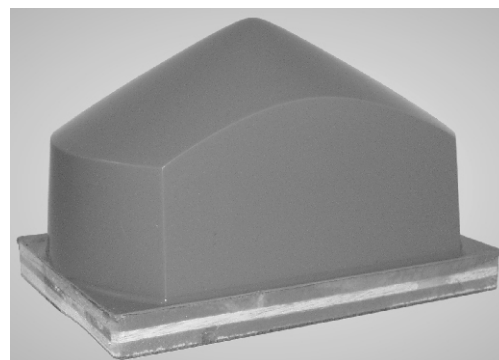

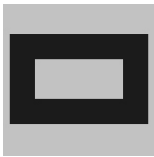

# LÜCK® TAMPON

H = Höhe  
L = Länge  
B = Breite

Nr. 29

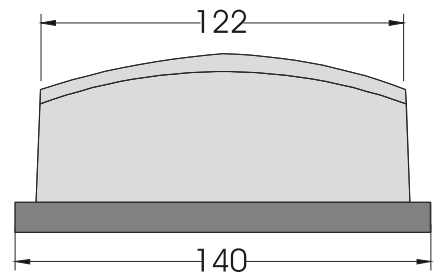
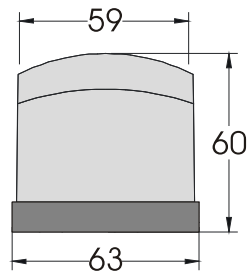
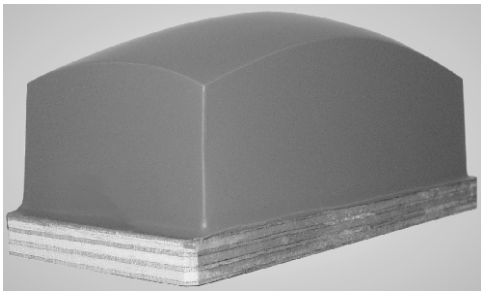

Nr. 278

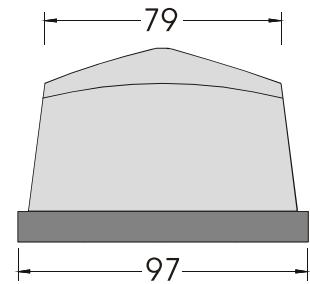
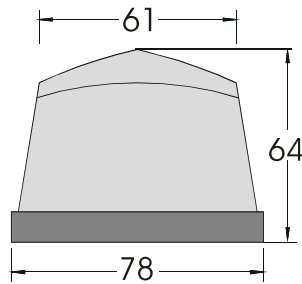
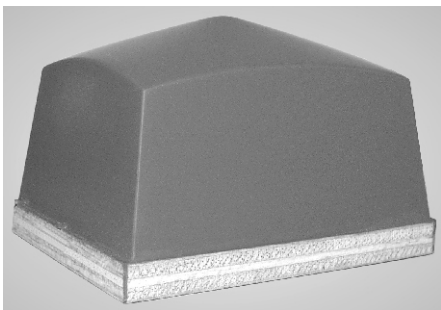

Nr. 1004

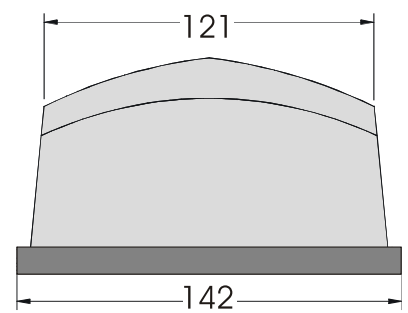
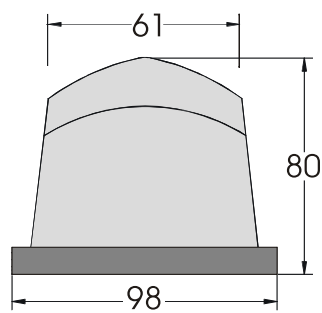
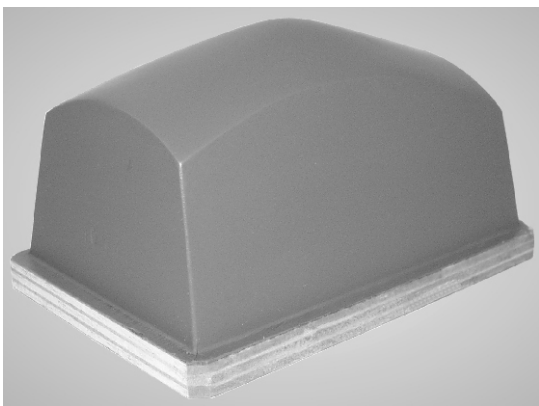

Nr. 55

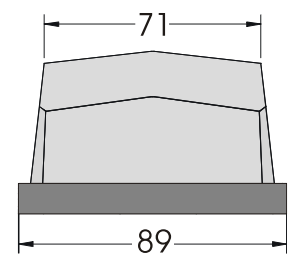
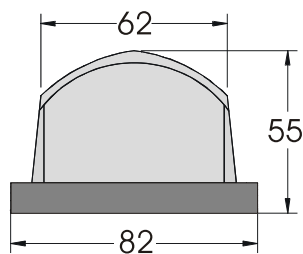
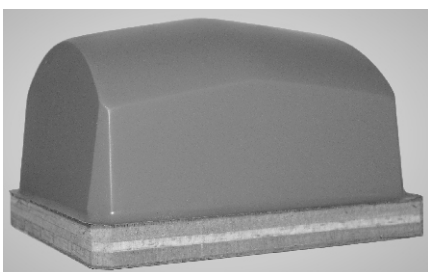

36

H = height  
 B = width  
 L = length

**LÜCK®**  
**TAMPON**

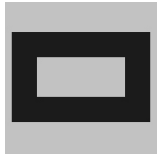

Nr. 61

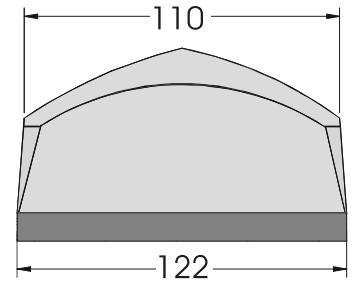
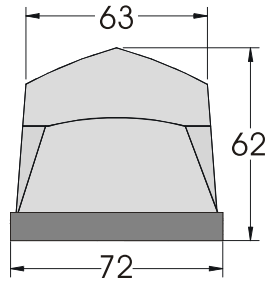
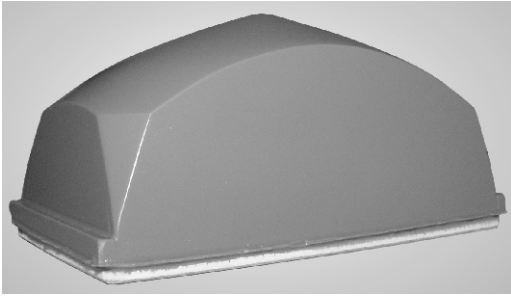

Nr. 59

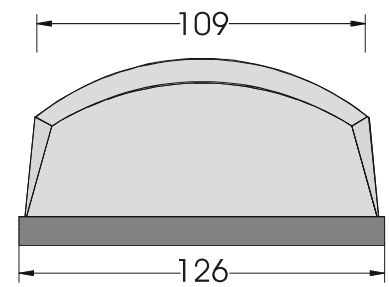
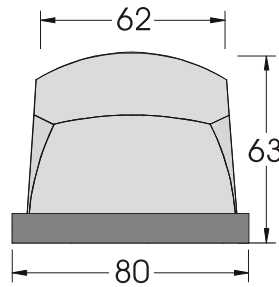
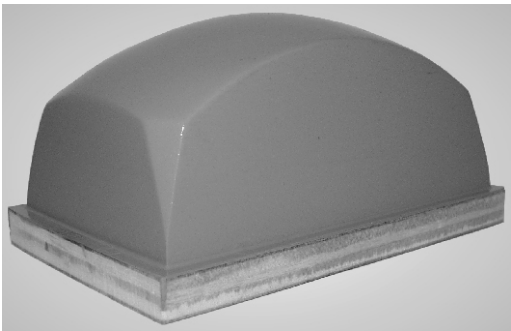

Nr. 971

Nr. 971K L 167 B 68 H 62

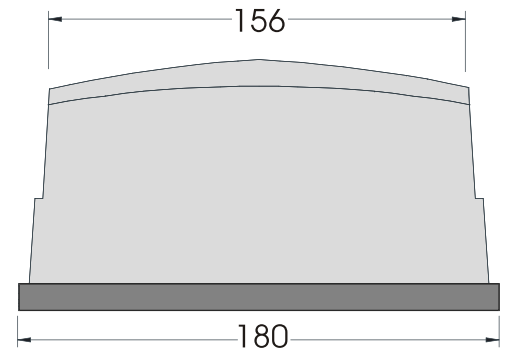
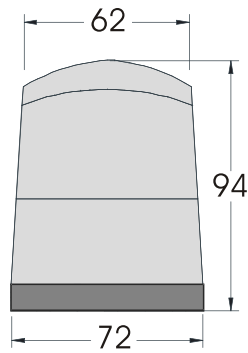
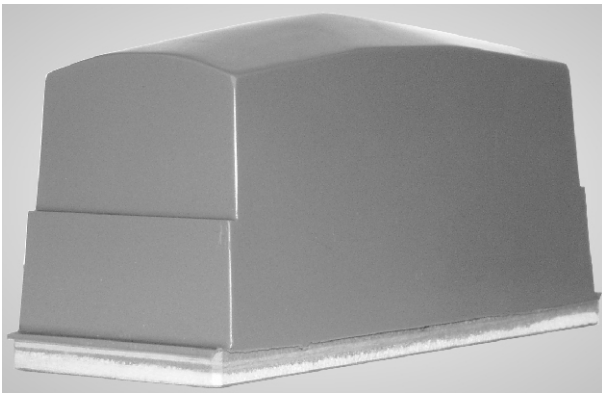

Nr. 346

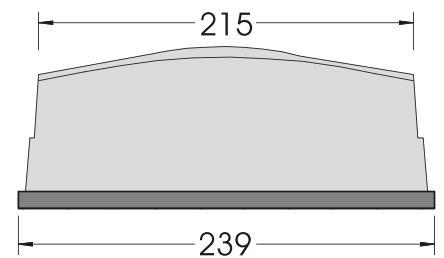
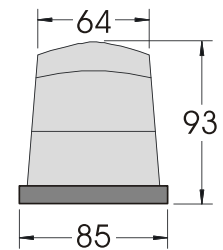
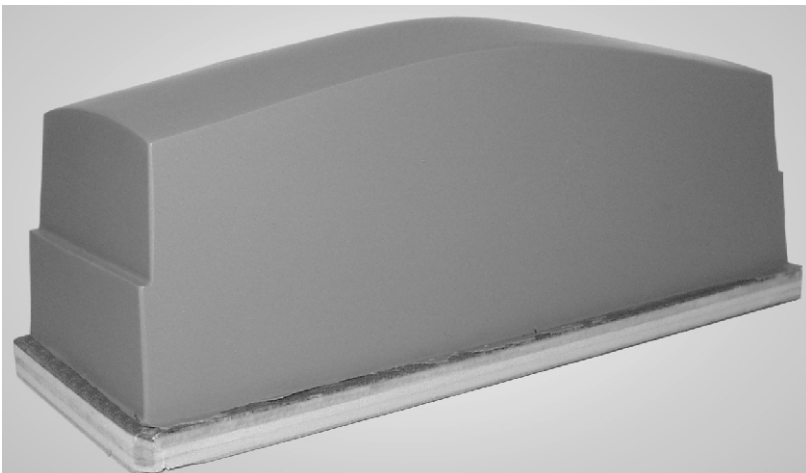

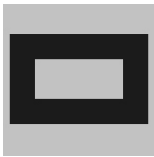

# LÜCK® TAMPON

H = Höhe  
B = Breite  
L = Länge

Nr. 147

Nr. 147K H 66

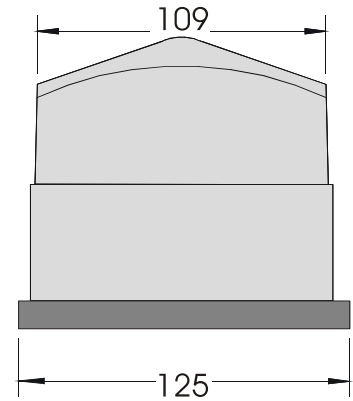
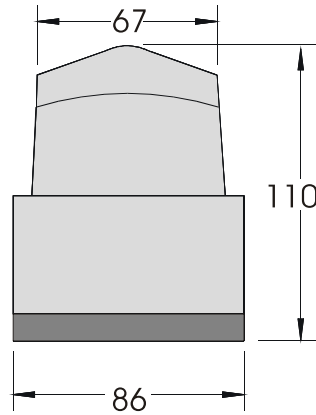
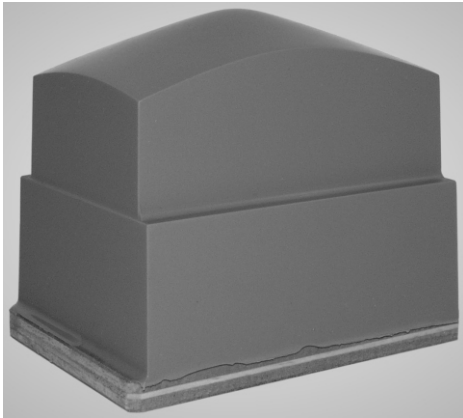

Nr. 144

Nr. 144K H 65

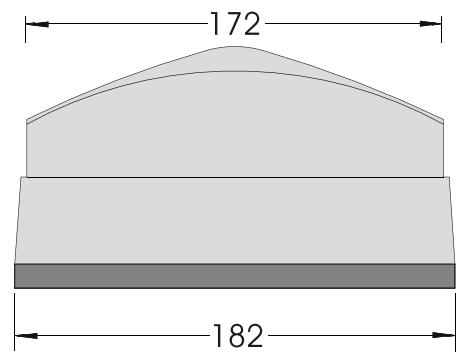
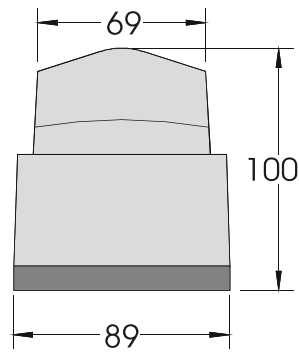
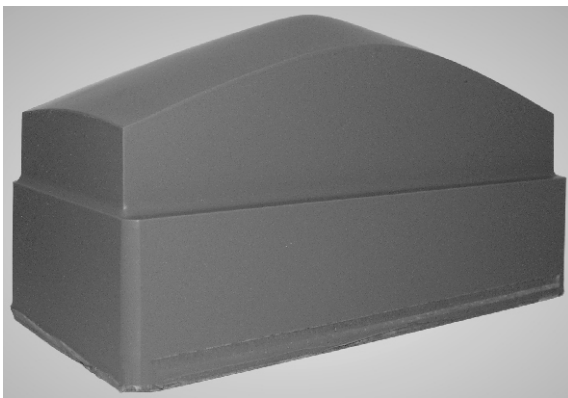

Nr. 407

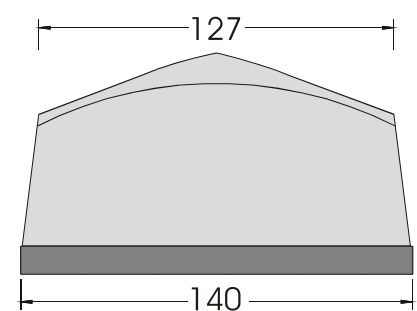
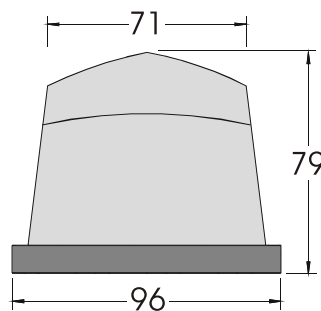
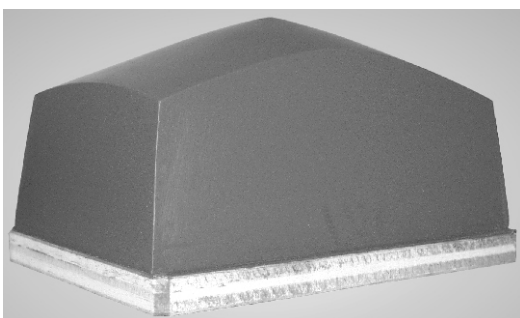

Nr. 84

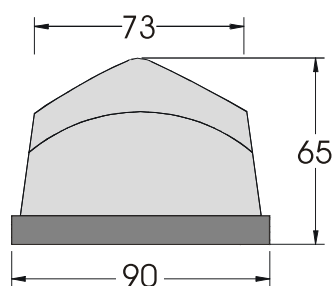
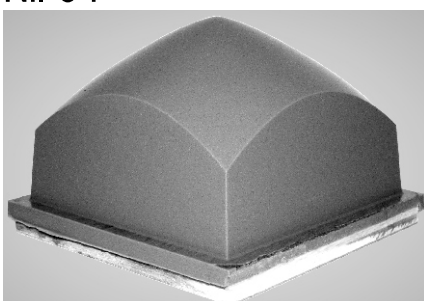

H = height  
B = width  
L = length

# LÜCK® TAMPON

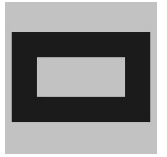

## Nr. 282

Nr. 282K H 63

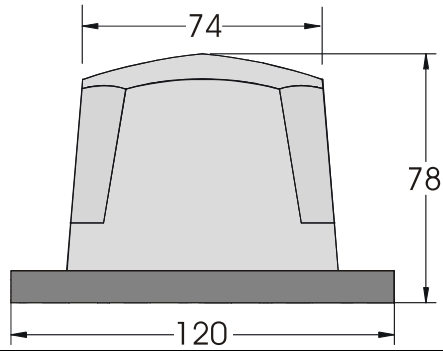
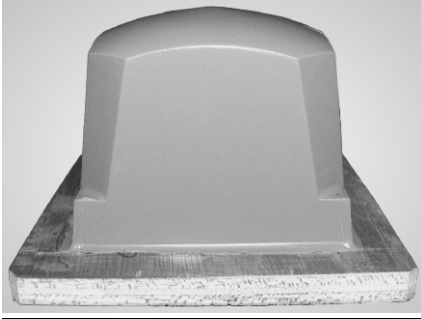

## Nr. 53

Nr. 53K L 127 B 84 H 63

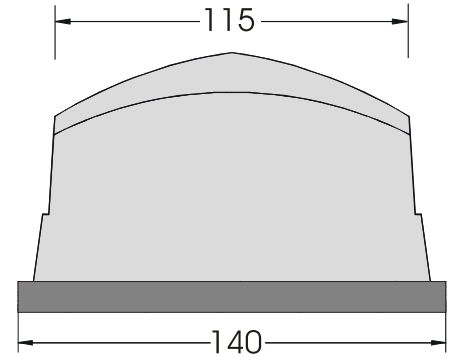
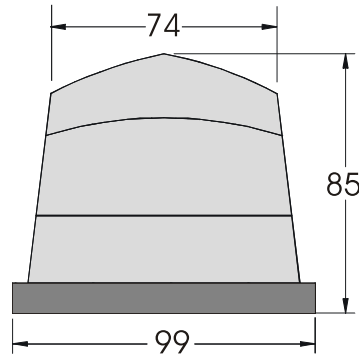
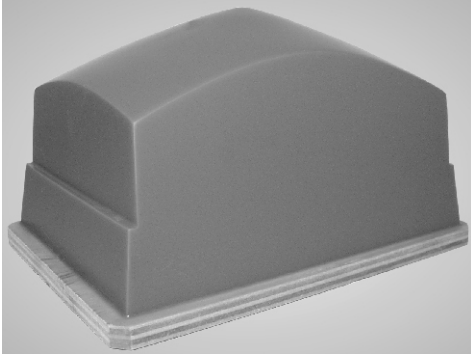

## Nr. 623

Nr. 623K H 70

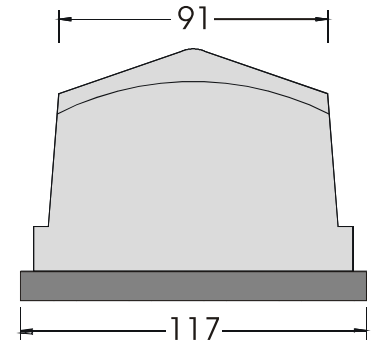
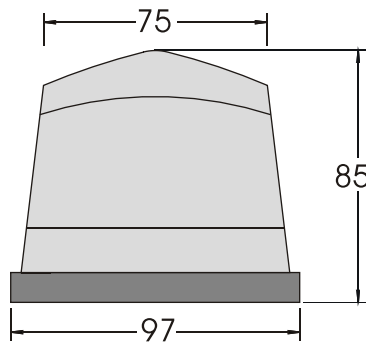
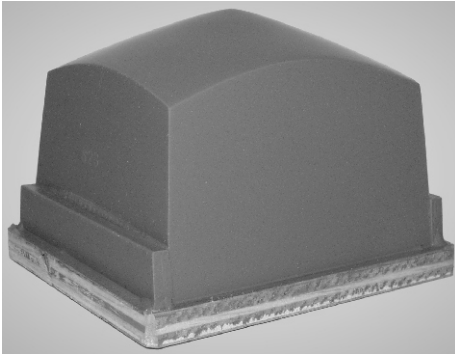

## Nr. 141

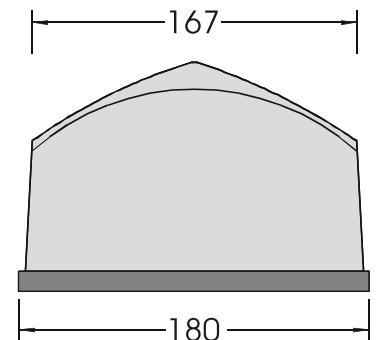
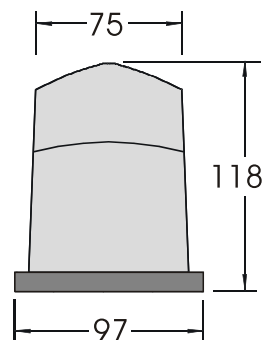
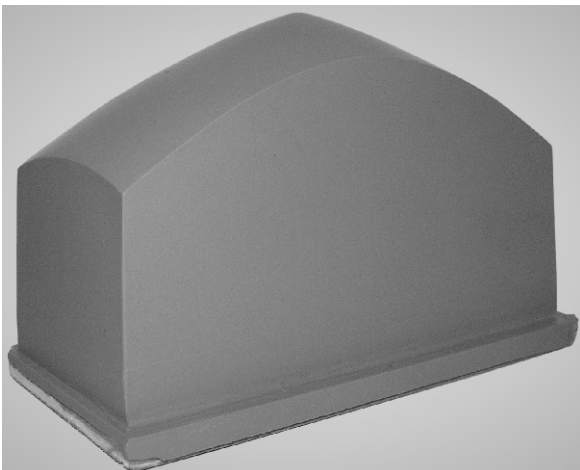

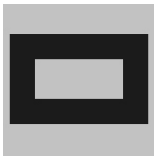

# LÜCK® TAMPON

H = Höhe  
B = Breite  
L = Länge

Nr. 54

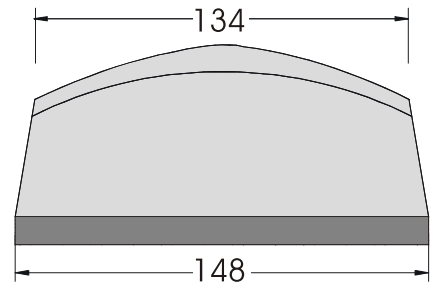
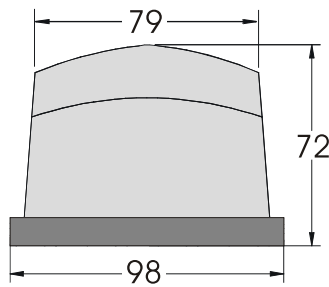
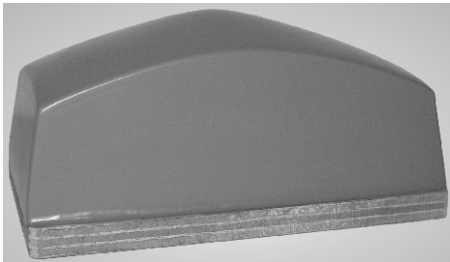

Nr. 143

Nr. 143K H 65

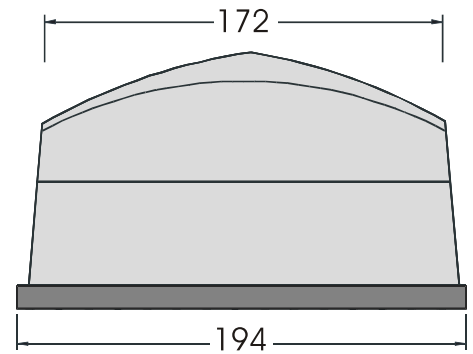
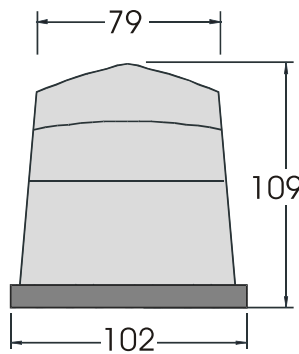
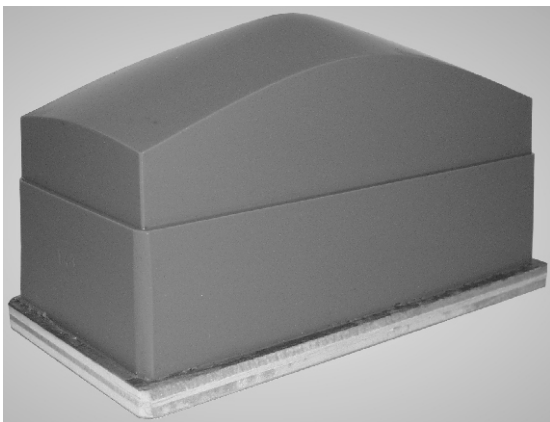

Nr. 146

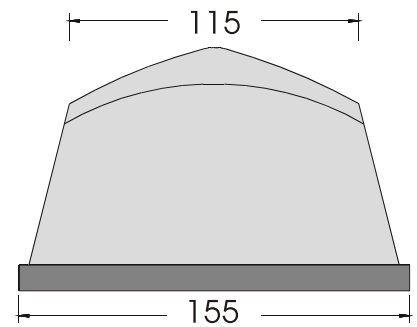
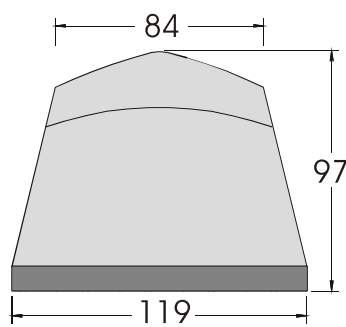
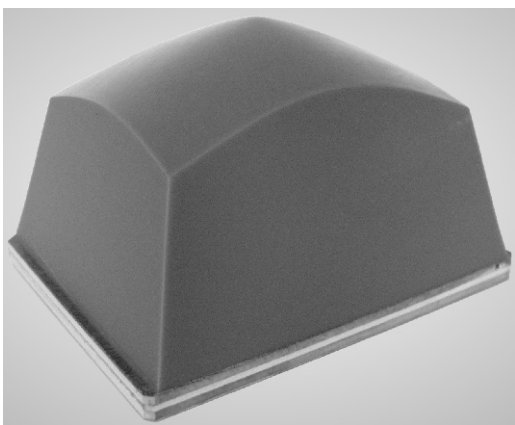

Nr. 80

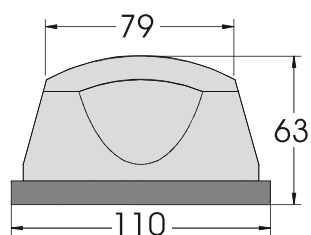
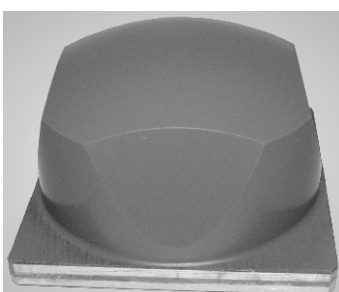

Nr. 884

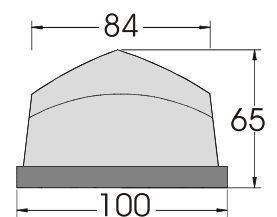
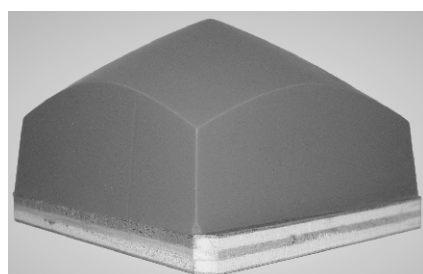



H = height  
B = width  
L = length

# LÜCK®

## TAMPON

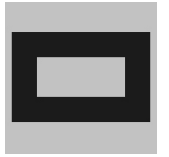

### Nr. 342

Nr. 342K L 226 B 92 H 60

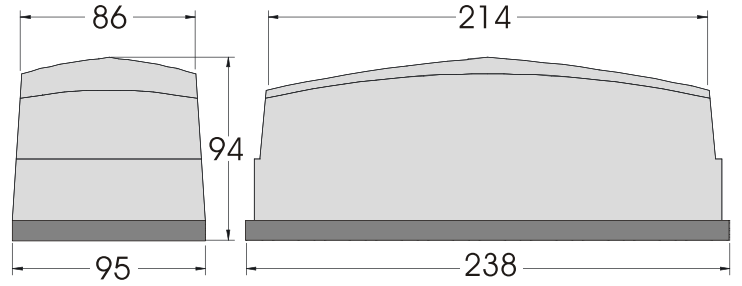
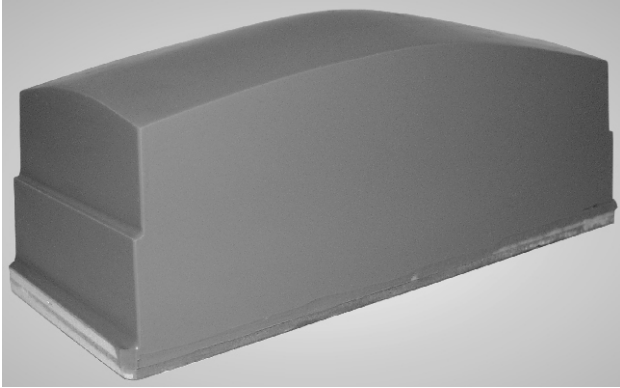

### Nr. 343

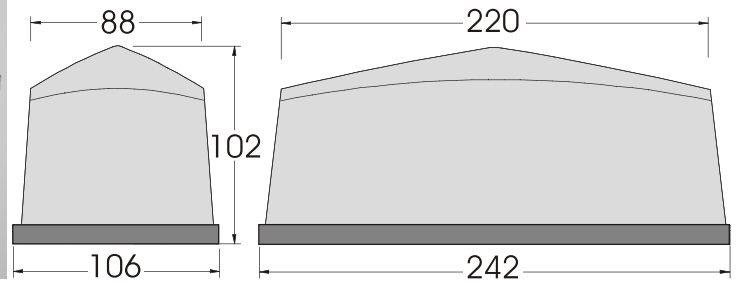
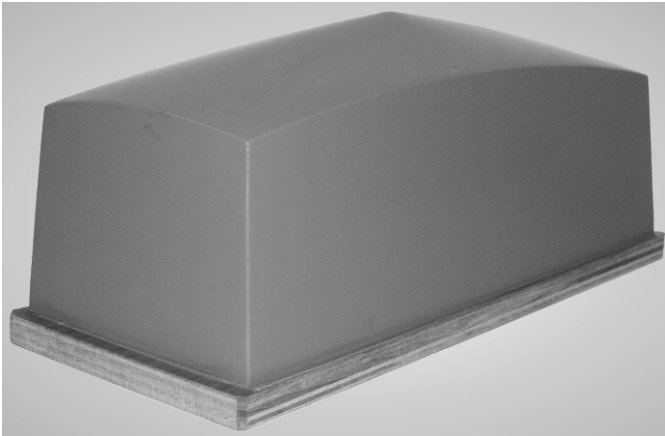

### Nr. 142

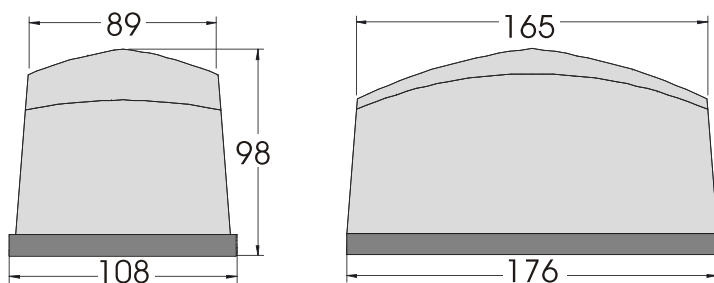
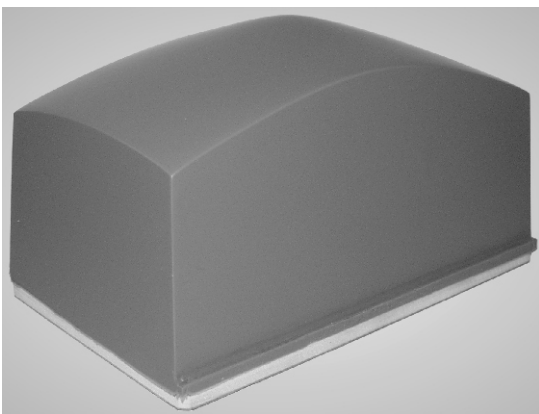

### Nr. 281

Nr. 281K H 64

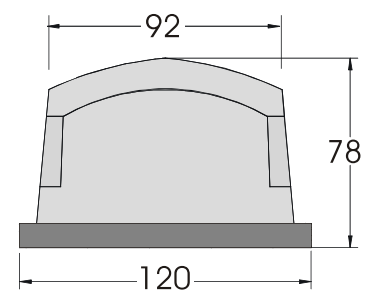
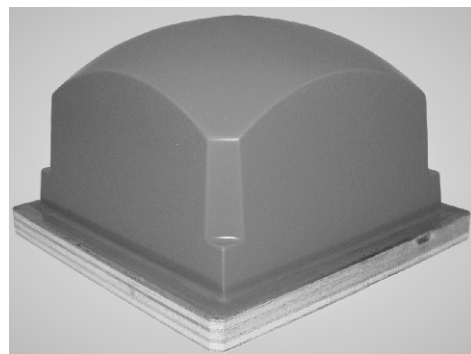



# LÜCK® TAMPON

H = Höhe  
B = Breite  
L = Länge

Nr. 240

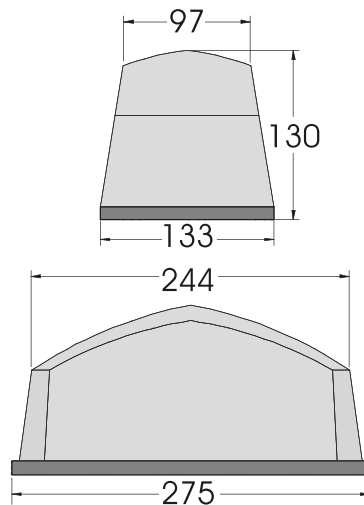
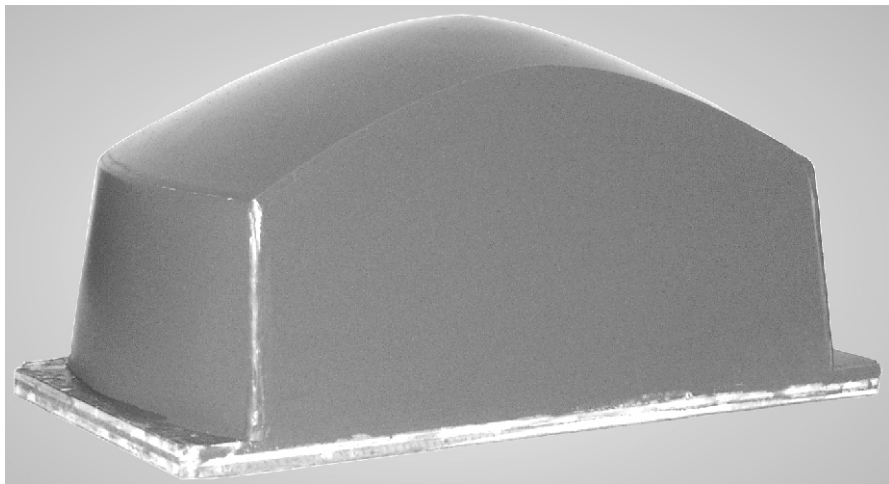

Nr. 283

Nr. 283K H 48

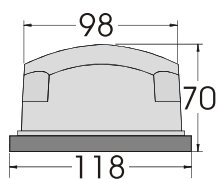
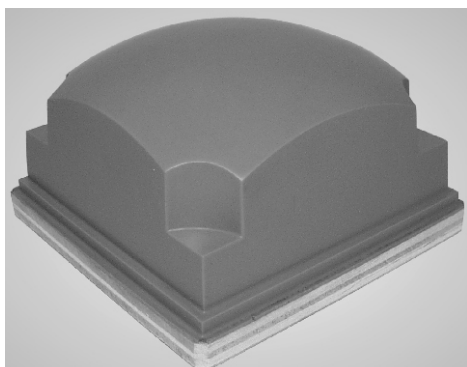

Nr. 280

Nr. 280K H 64

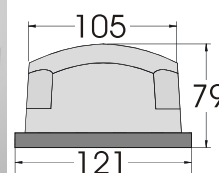
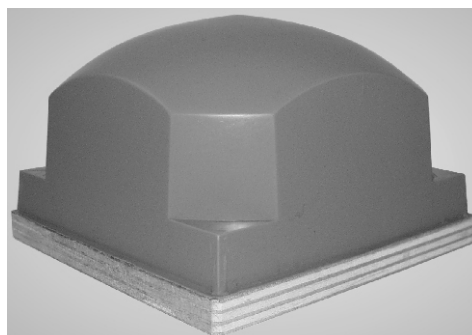

Nr. 1202

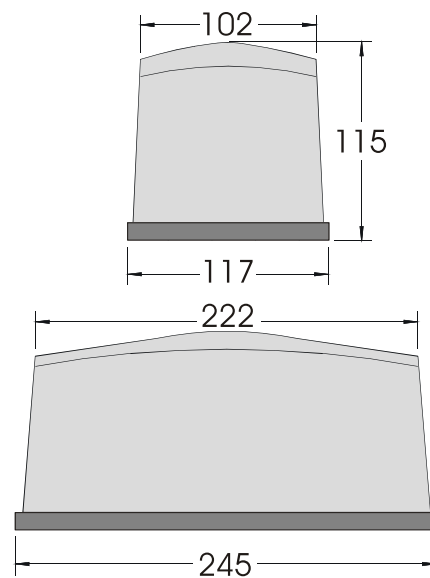
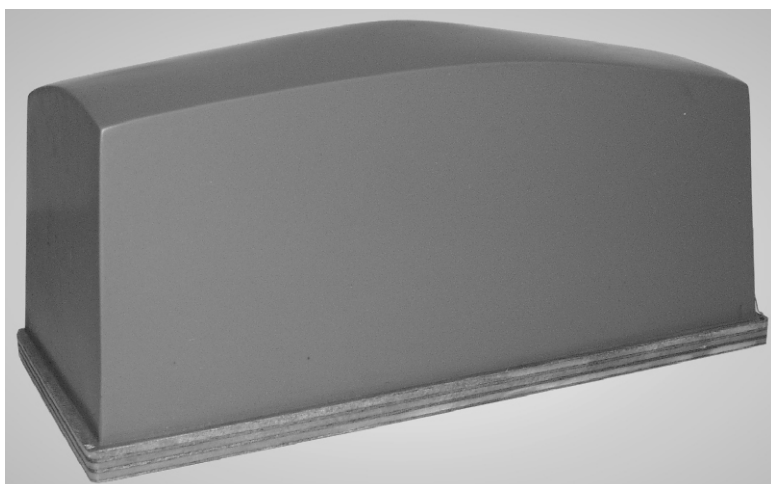

H = height  
B = width  
L = length

# LÜCK® TAMPON

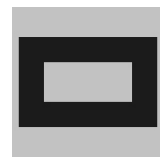

Nr. 210

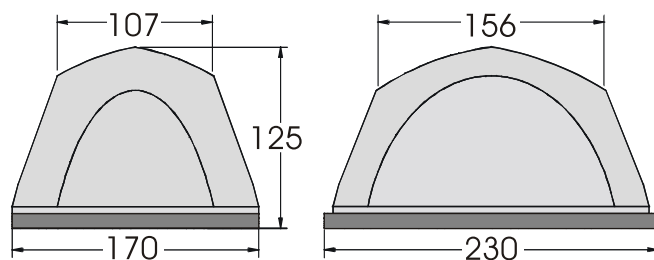
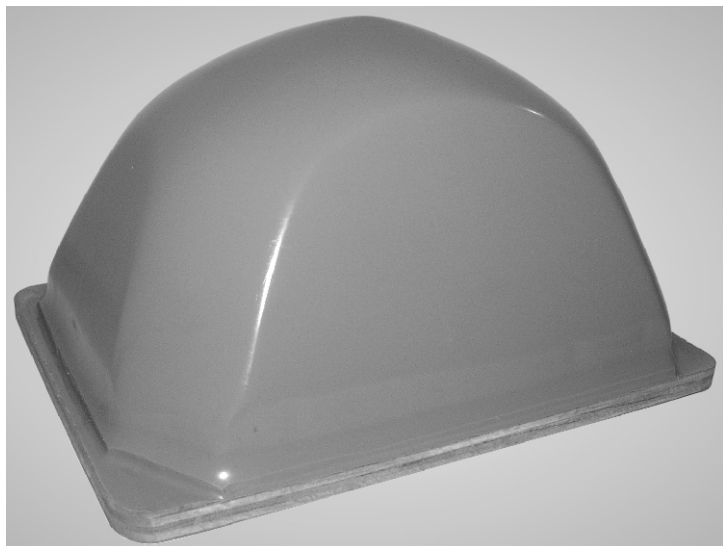

Nr. 180

Nr. 180K L 193 B 121 H 75

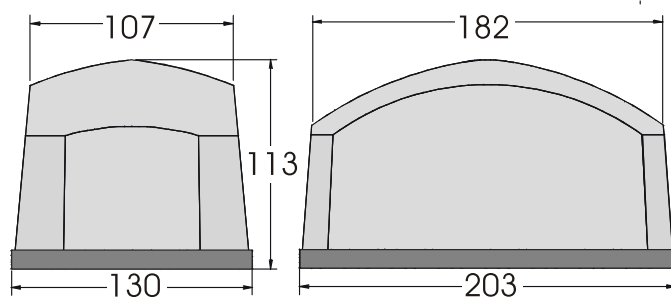
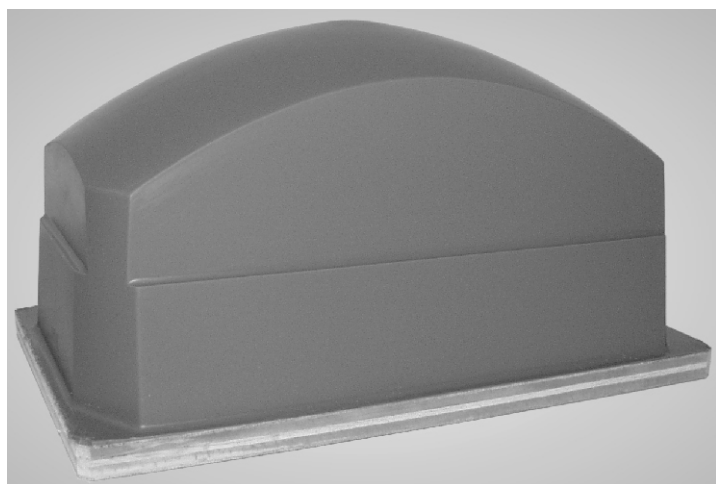

Nr. 284

Nr. 284K H 75

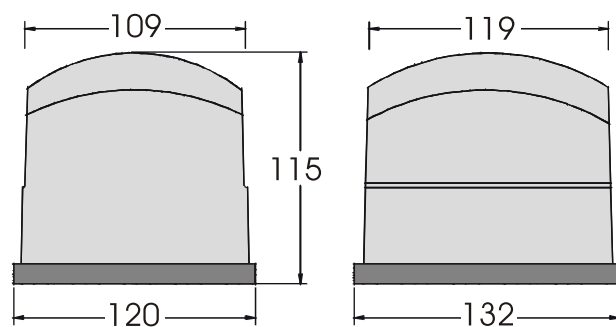
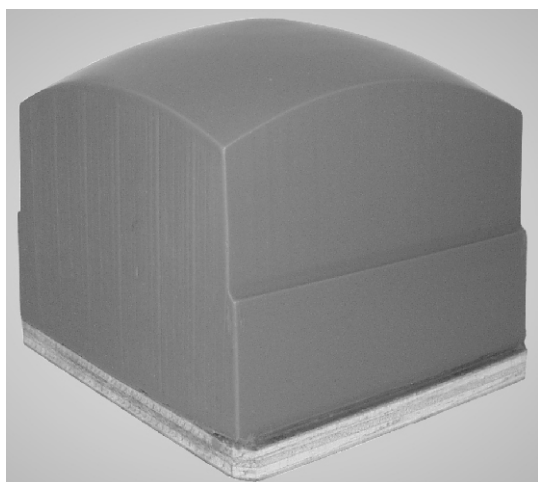

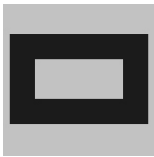

# LÜCK® TAMPON



Nr. 179

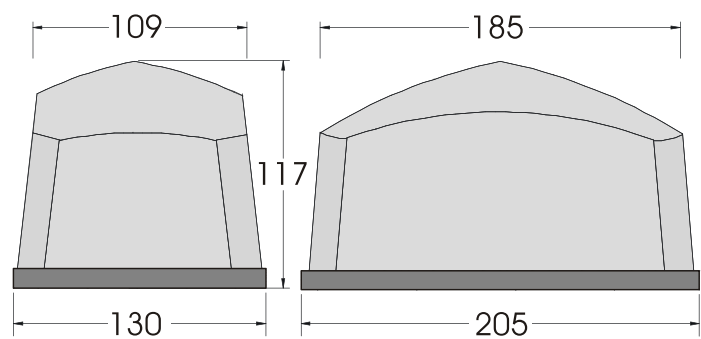
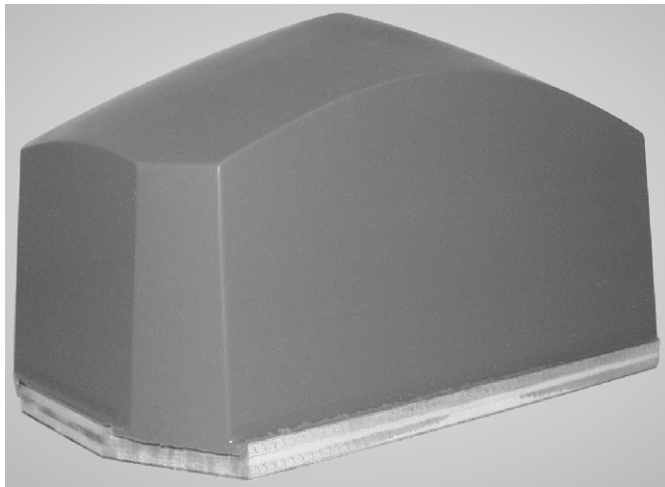

Nr. 145

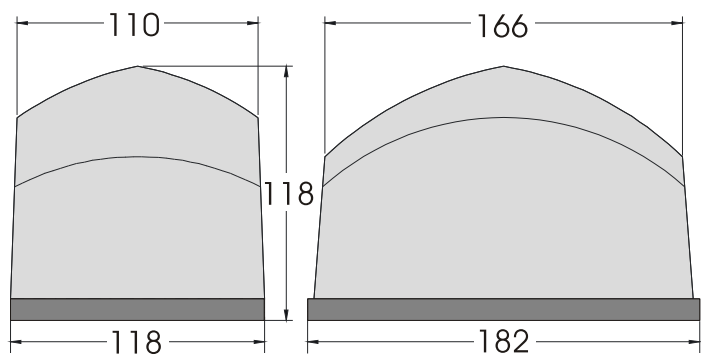
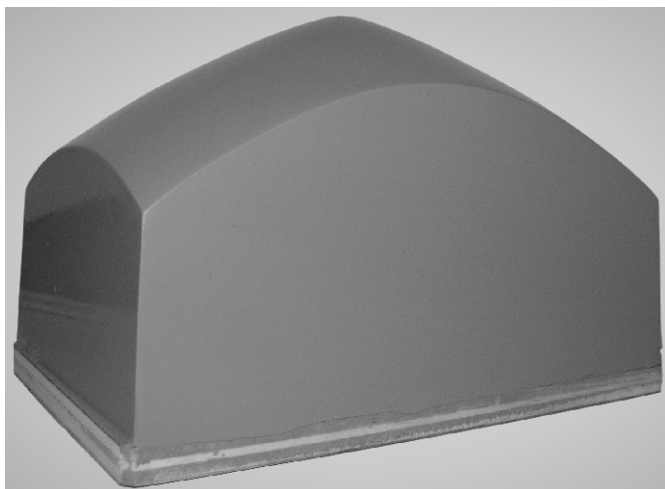

Nr. 223

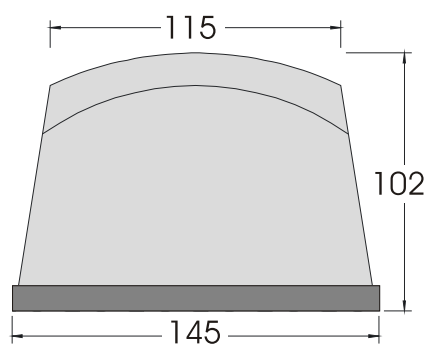
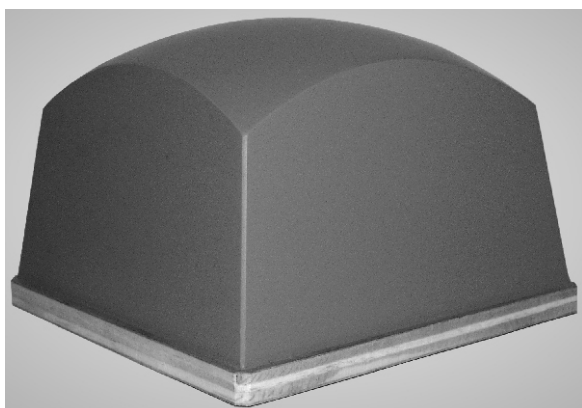



**LÜCK**<sup>®</sup>  
**TAMPON**

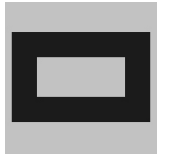

Nr. 222

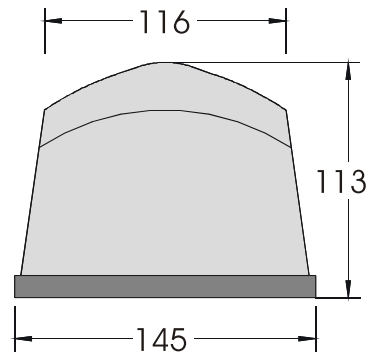
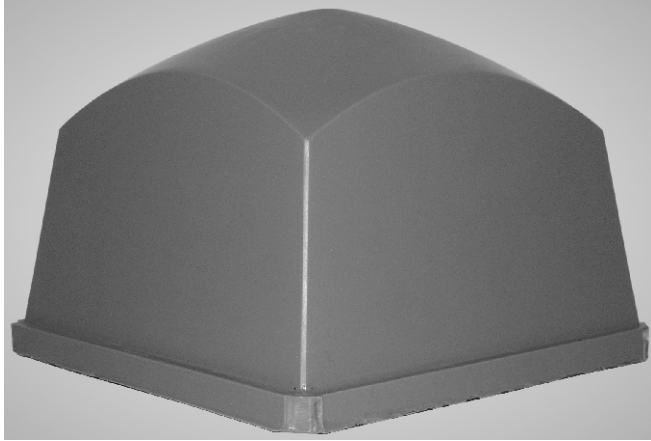

Nr. 220

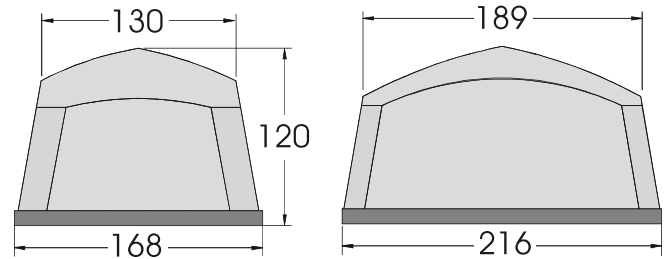
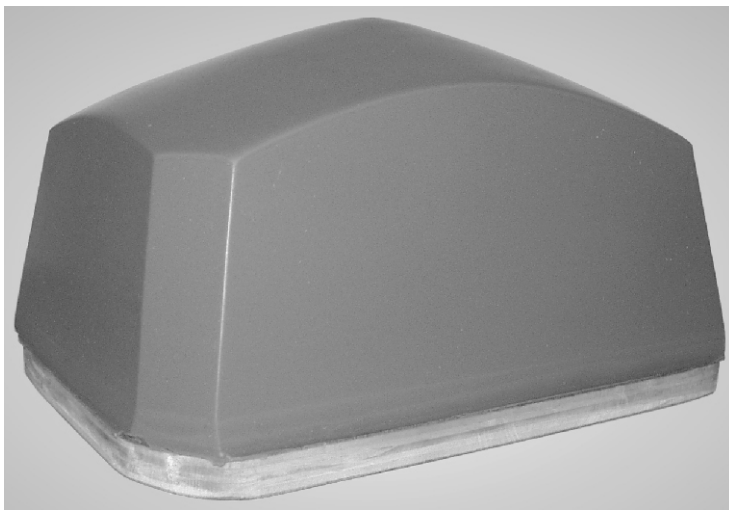

Nr. 221

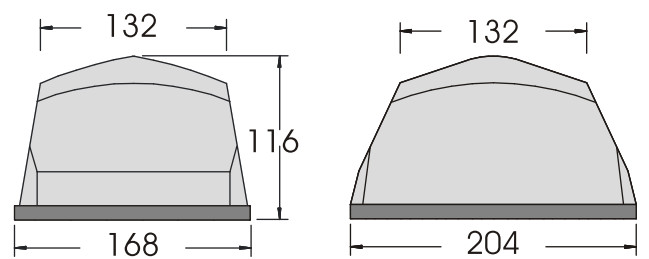
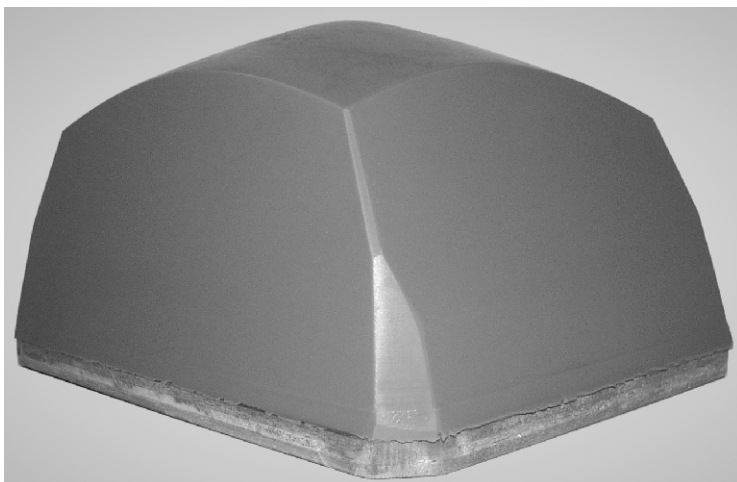

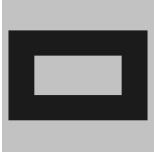

# LÜCK® TAMPON

H = Höhe  
B = Breite  
L = Länge  
SL = Silikonlänge

Nr. 224/115

Nr. 224/105 L 174 B 160 H 105

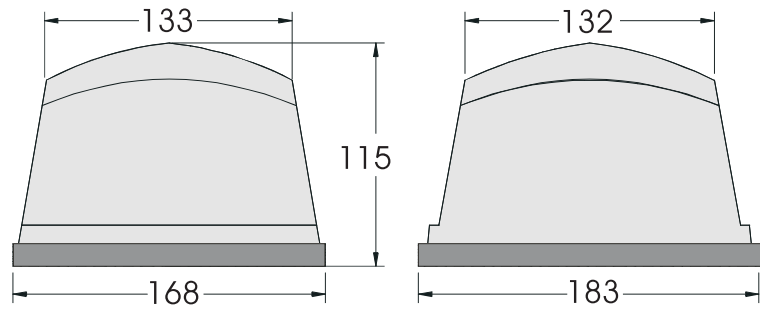
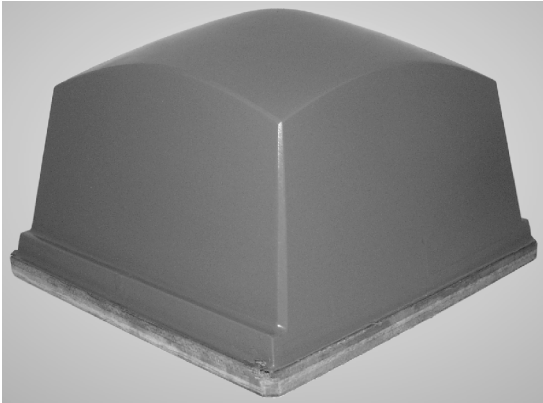

Nr. 260

Nr. 260K L 278 B 182 H 106

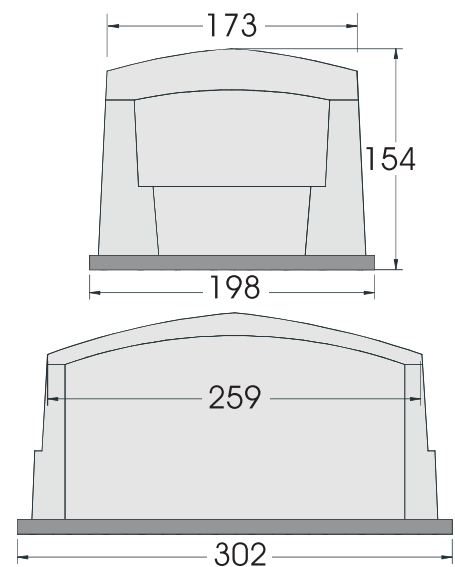
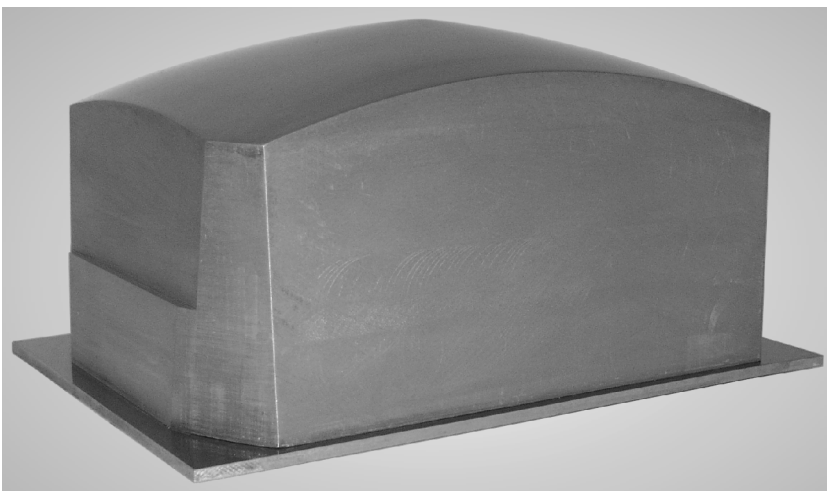

Nr. 305

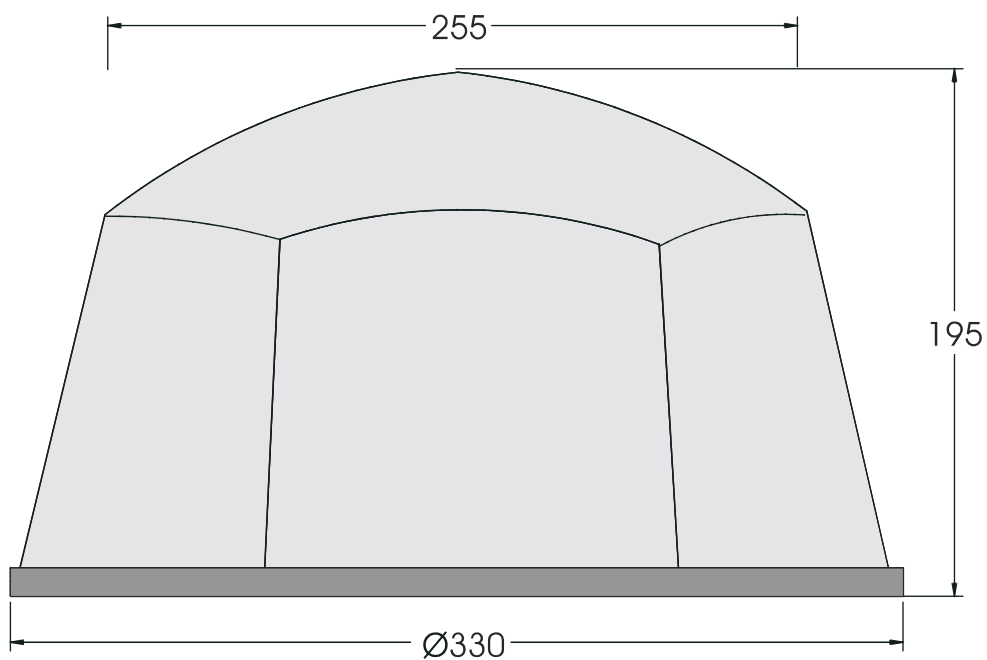

H = height  
 B = width  
 L = length  
 SL = silicone length

# LÜCK® TAMPON



**Nr. 522 Alu M6**

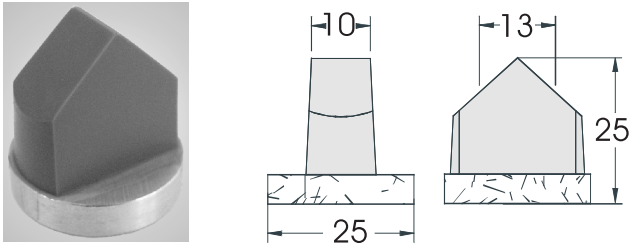

**Nr. 310**

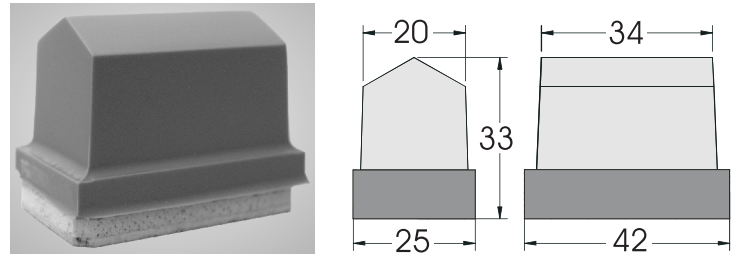

**Nr. 425**

Nr. 425 Alu M6 H 39

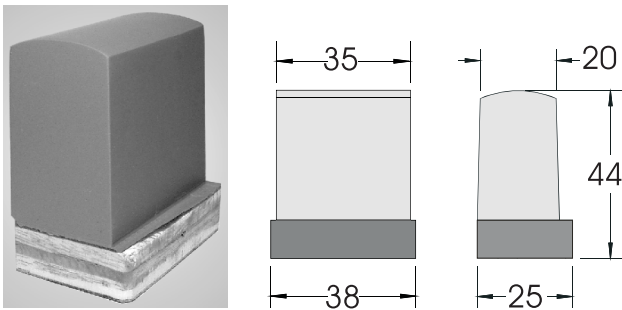

**Nr. 1005**

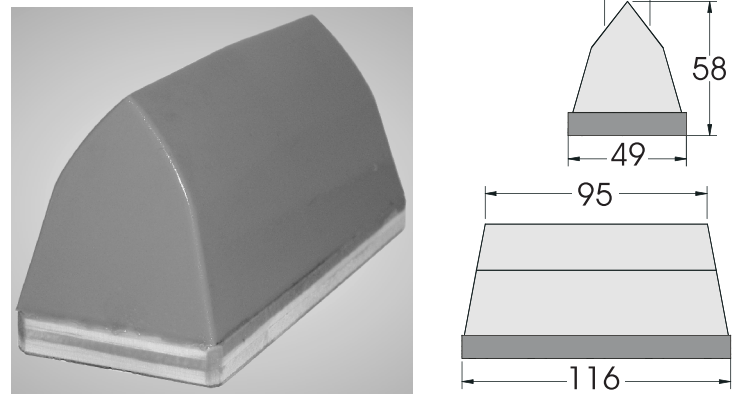

**Nr. 592**

Nr. 592 Alu M6 H 29

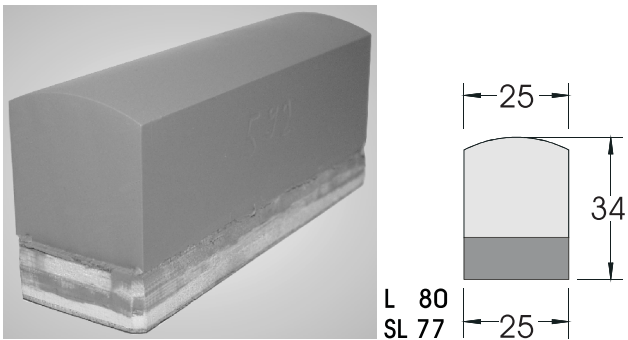

**Nr. 524**

Nr. 525 Druckfläche ohne Kante  
 (printing area without edge)

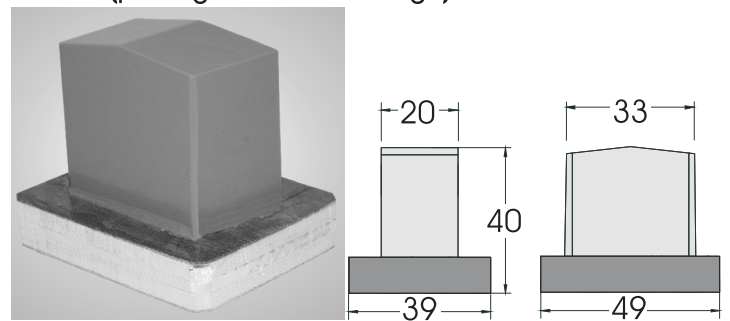

**Nr. 20**

Nr. 20S L 99 B 64 SL 80

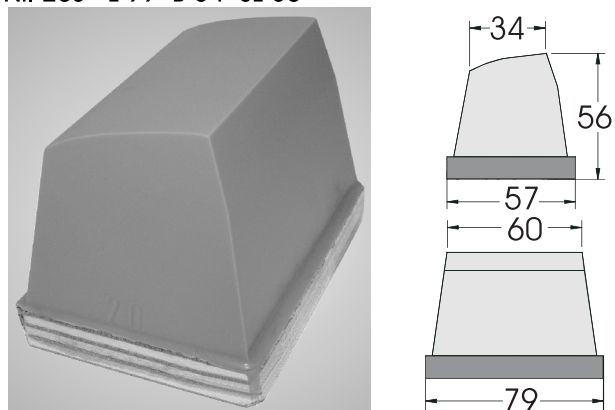

**Nr. 265**

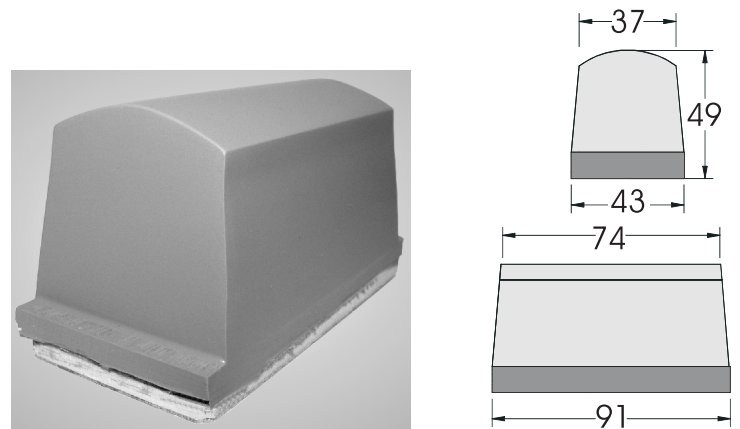



# LÜCK® TAMPON

B = Breite  
L = Länge  
SL = Silikonlänge

Nr. 406

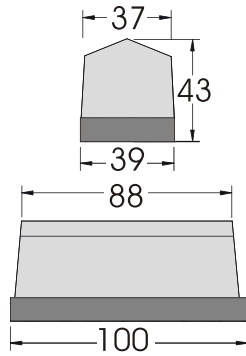
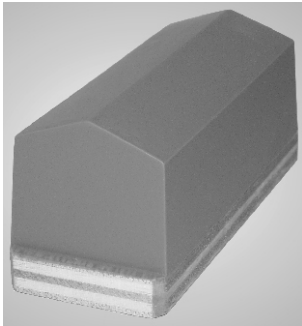

Nr. 21

Nr. 21S B 58

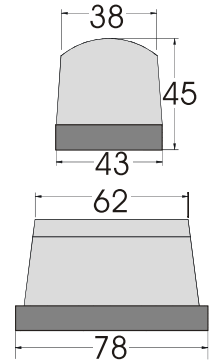
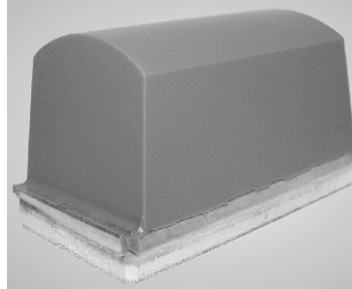

Nr. 447

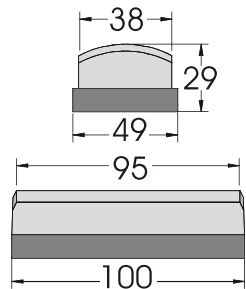
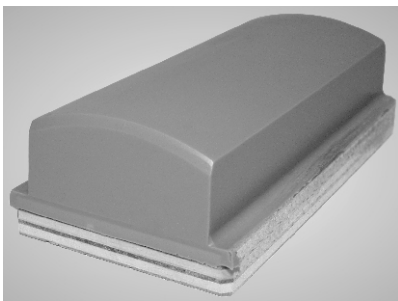

Nr. 563

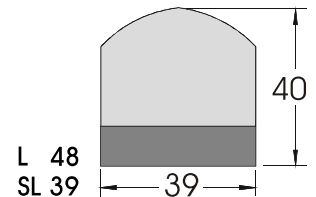
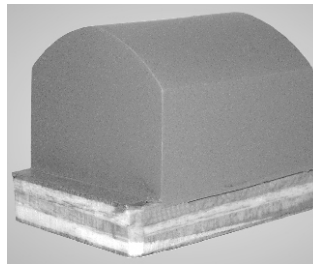

Nr. 891

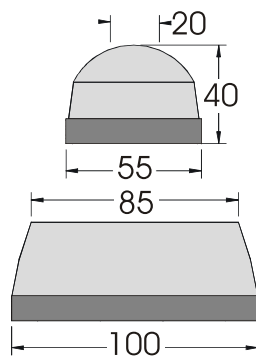
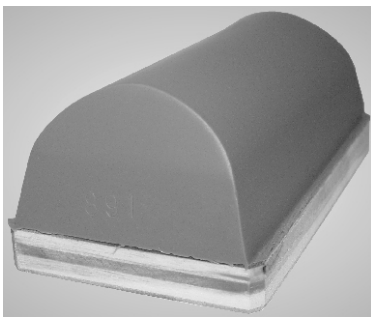

Nr. 404

Nr. 404K L 74 SL 63

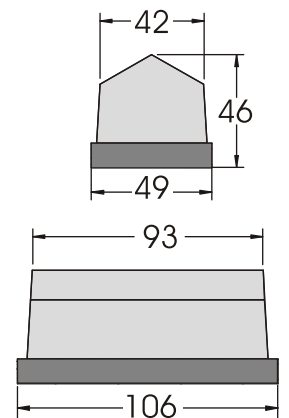
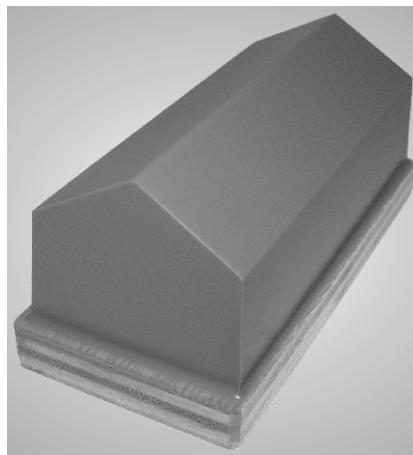

Nr. 446

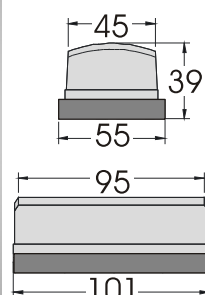
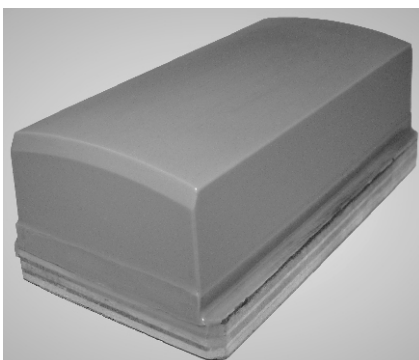

Nr. 445

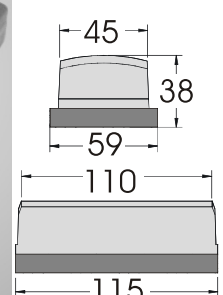
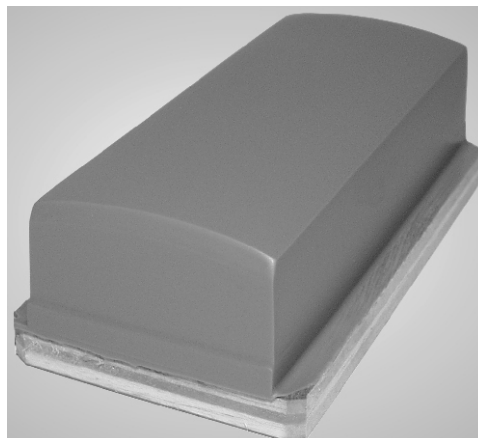



B = width  
L = length  
SL = silicone length

# LÜCK® TAMPON

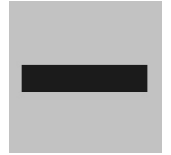

Nr. 528

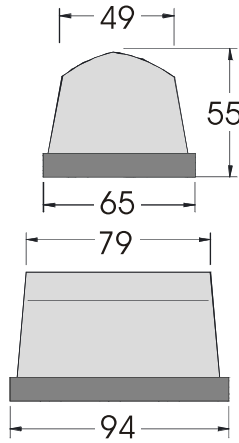
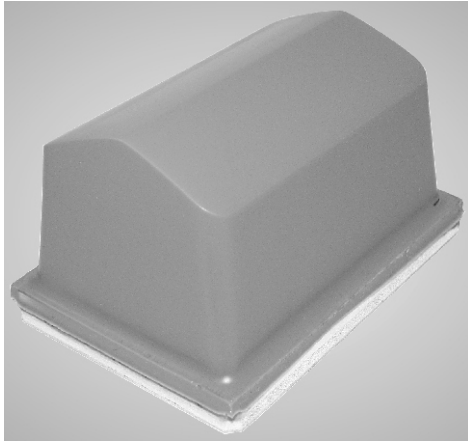

Nr. 51

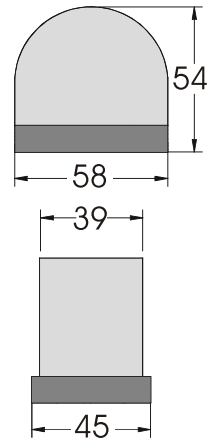
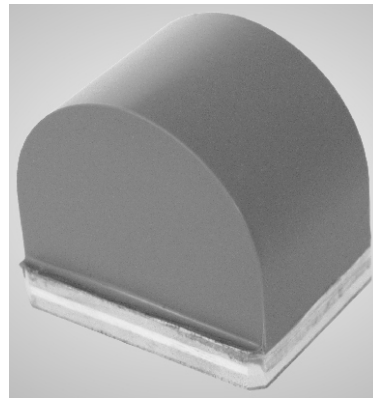

Nr. 799

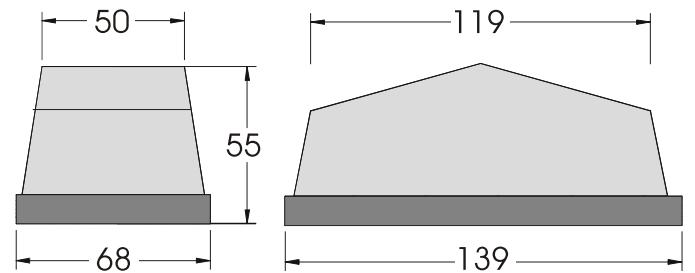
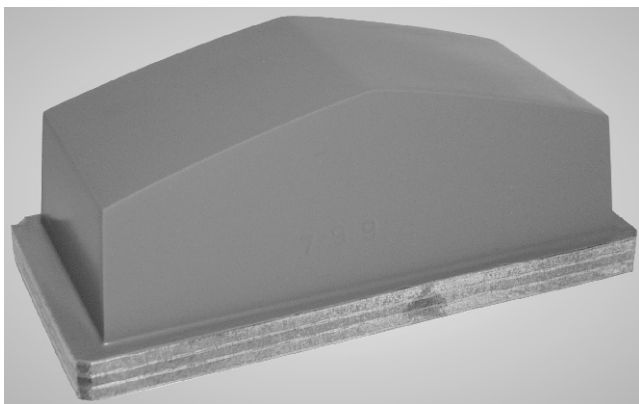

Nr. 200

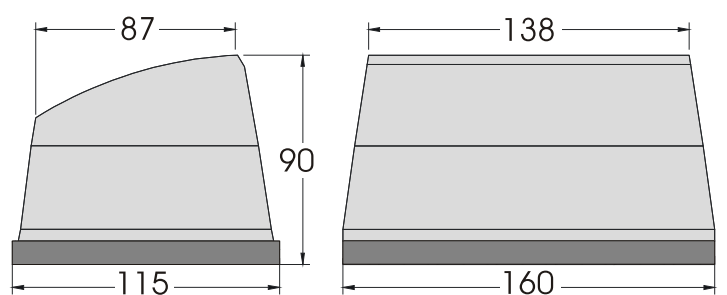
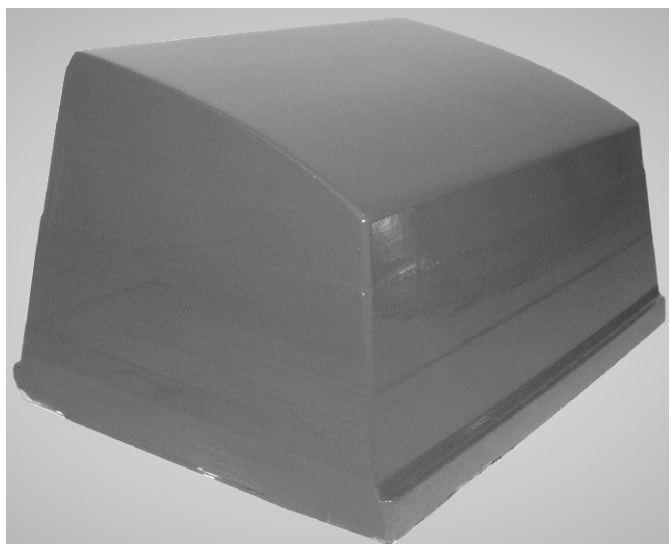



# LÜCK® TAMPON

H = Höhe  
L = Länge  
SL = Silikonlänge

Nr. 2018 Alu

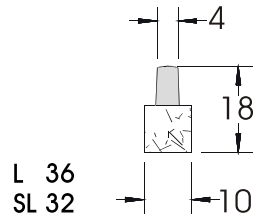
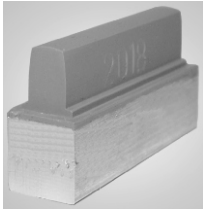

Nr. 7270

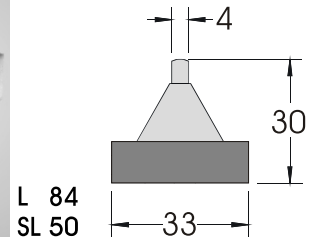
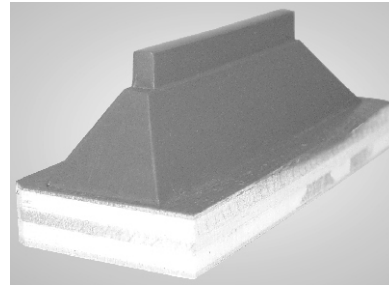

Nr. 7271

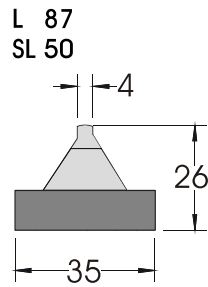
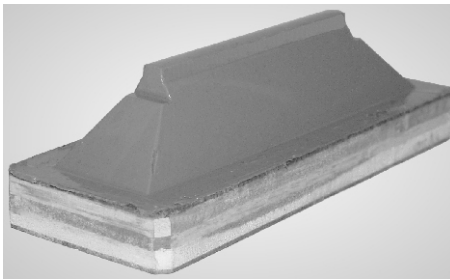

Nr. 99 Alu

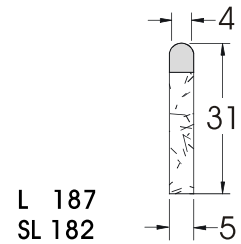
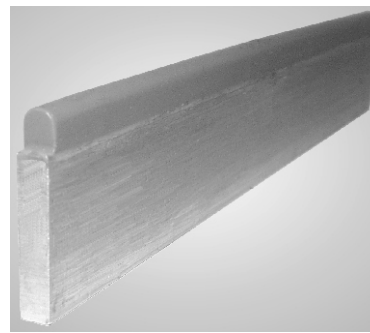

Nr. 7268

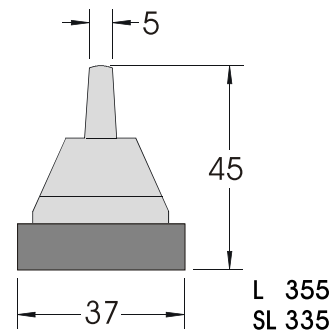
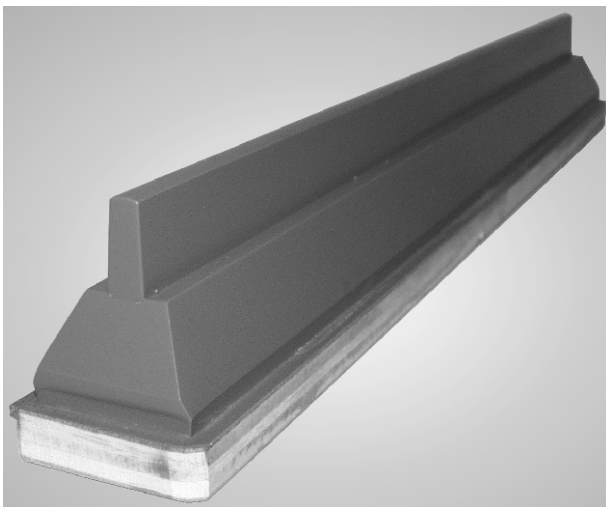

Nr. 680

- Nr. 6801 L 62 SL 49
- Nr. 6802 L 108 SL 94
- Nr. 6803 L 132 SL 119
- Nr. 6804 L 161 SL 149
- Nr. 6805 L 212 SL 199
- Nr. 6806 L 256 SL 244

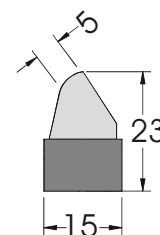
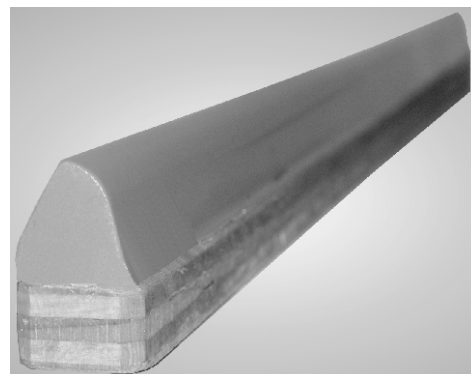

L 434  
SL 431

H = height  
 L = length  
 SL = silicone length

# LÜCK®

## TAMPON

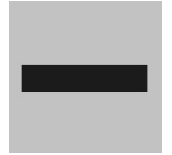

### Nr. 69

Nr. 69 Alu M5 H 18

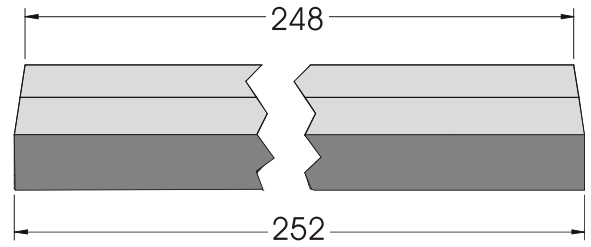
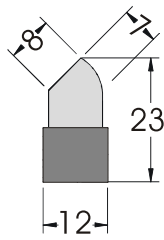
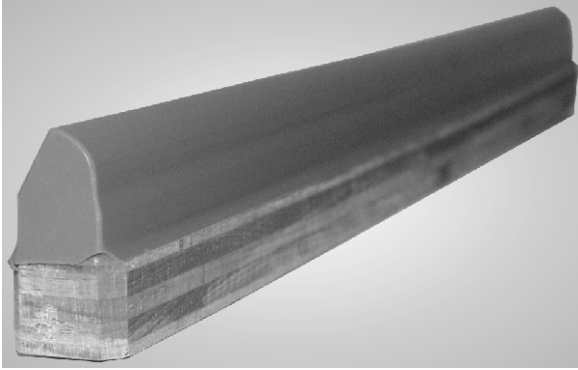

### Nr. 1106

- Nr. 1101 L 48 SL 30
- Nr. 1102 L 78 SL 60
- Nr. 1103 L 98 SL 80
- Nr. 1104 L 137 SL 120
- Nr. 1105 L 187 SL 169

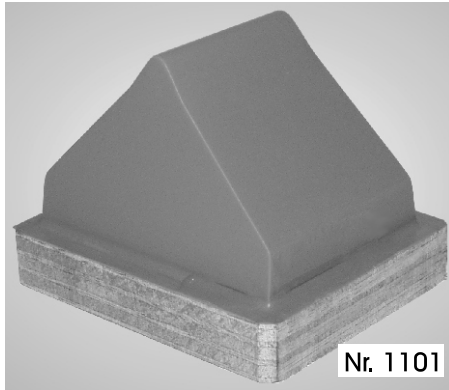

Nr. 1101

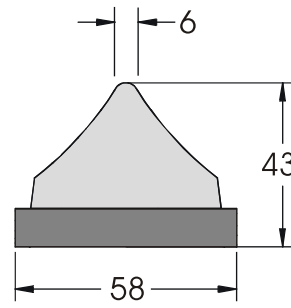

L 247  
 SL 229

### Nr. 100

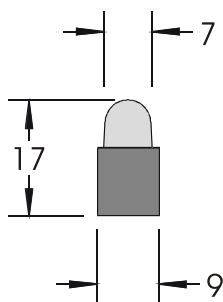
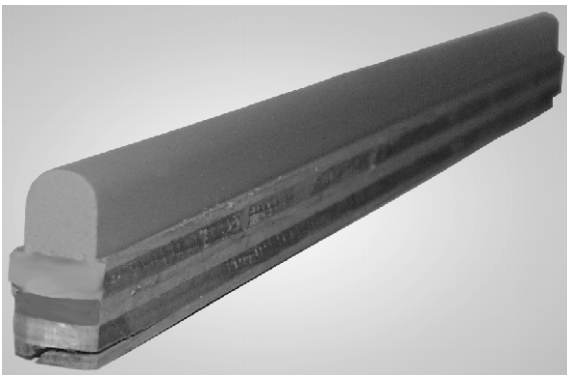

L 241  
 SL 241

### Nr. 68

Nr. 68 Alu

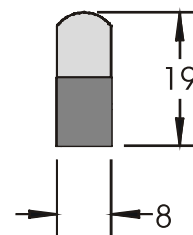
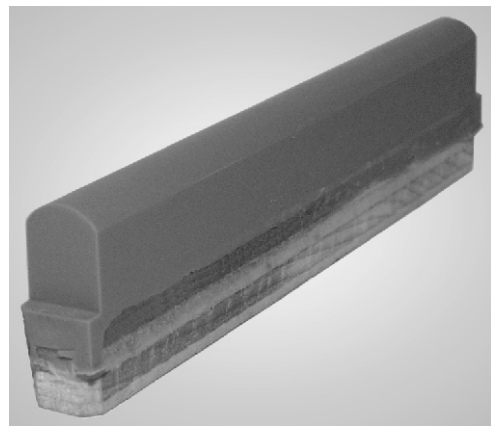

L 88  
 SL 84



# LÜCK® TAMPON

H = Höhe  
L = Länge  
SL = Silikonlänge

## Nr. 58 Alu M5

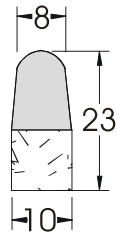
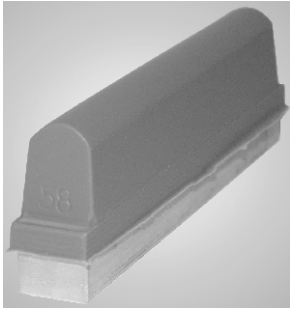

L 74  
SL 68

## Nr. 38 Alu M5

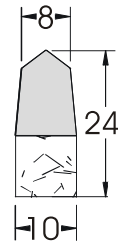
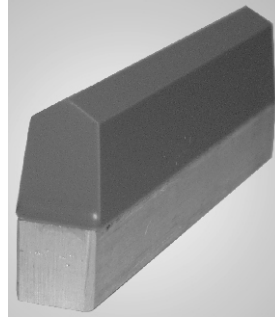

L 75  
SL 68

## Nr. 98

Nr. 98 Alu M6

Nr. 498/72 Alu M5 L 74 SL 72 H 21

Nr. 98/85 L 89 SL 82

Nr. 98/85 Alu M6 L 89 SL 82

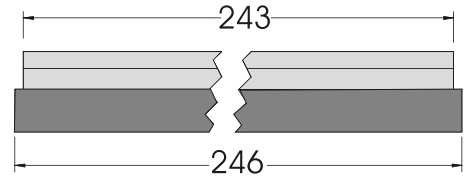
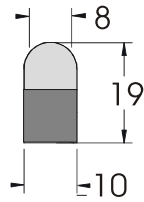
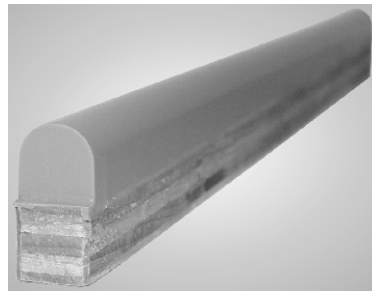

## Nr. 380

Nr. 3801 L 62 SL 49

Nr. 3802 L 107 SL 94

Nr. 3803 L 132 SL 119

Nr. 3804 L 162 SL 149

Nr. 3805 L 211 SL 199

Nr. 3806 L 256 SL 244

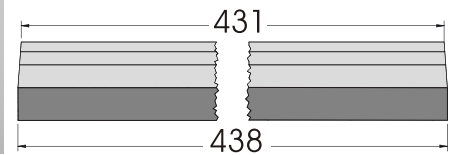
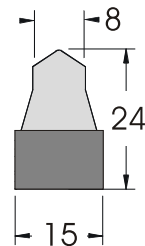
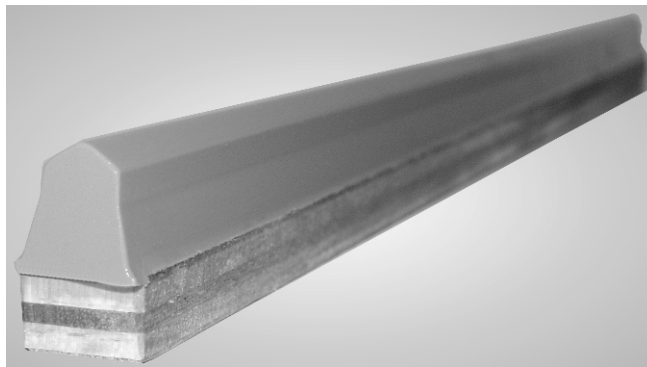

## Nr. 980

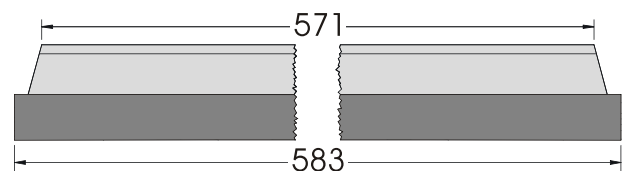
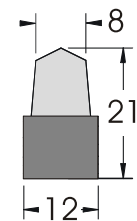
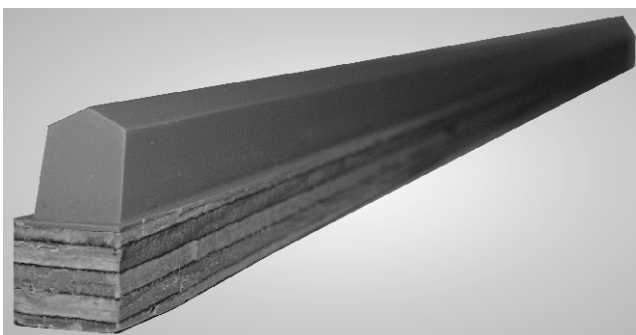

H = height  
L = length  
SL = silicone length

# LÜCK® TAMPON



**Nr. 629**  
Nr. 629 Alu M5

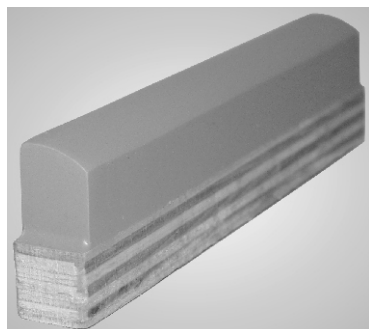

L 91  
SL 85

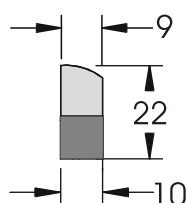

**Nr. 326 Alu M5**

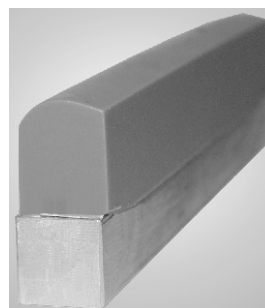

L 102  
SL 99

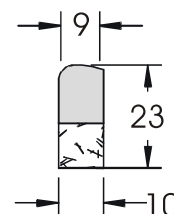

**Nr. 1120S**

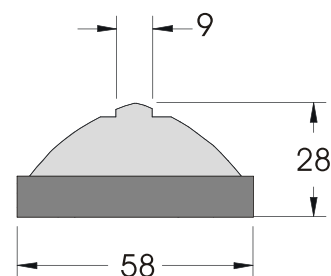
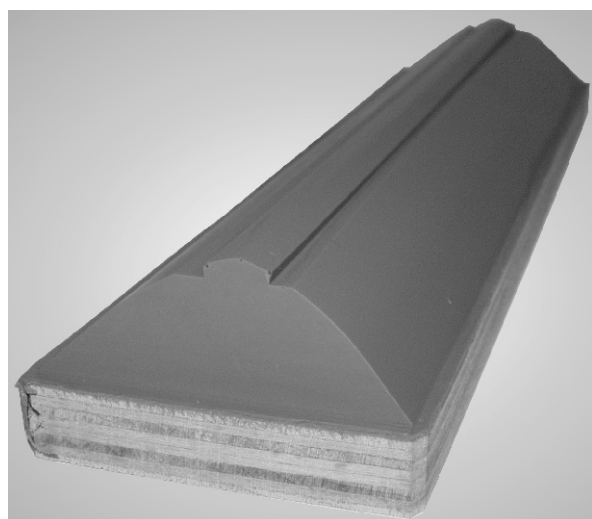

**Nr. 717**

- Nr. 7171 L 63 SL 49
- Nr. 7172 L 107 SL 94
- Nr. 7173 L 130 SL 119
- Nr. 7174 L 161 SL 149
- Nr. 7175 L 211 SL 198
- Nr. 7176 L 256 SL 244

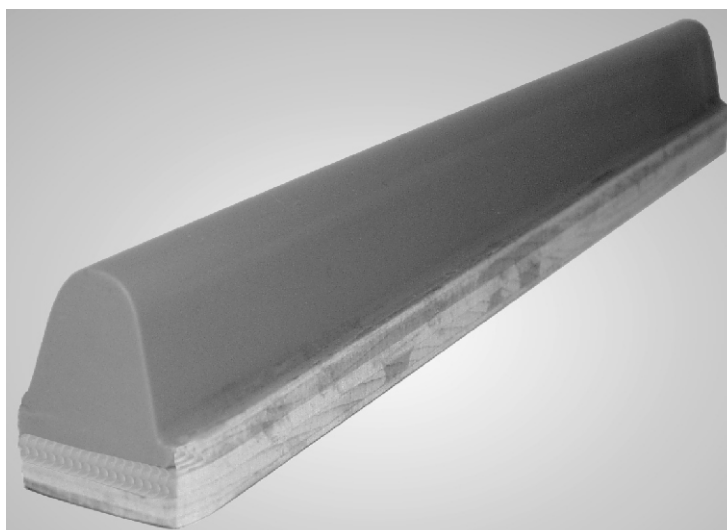

L 224  
SL 218

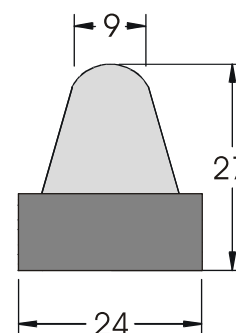



# LÜCK® TAMPON

H = Höhe  
L = Länge  
SL = Silikonlänge

## Nr. 327 Alu M5

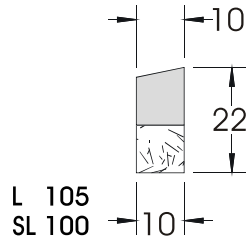
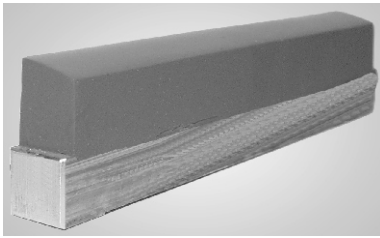

## Nr. 48

Nr. 48 Alu M6 H 24  
Nr. 48/46 Alu M6 L 50 SL 46 H 21

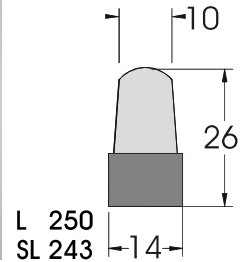
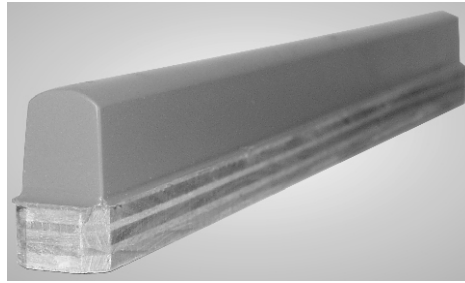

## Nr. 301

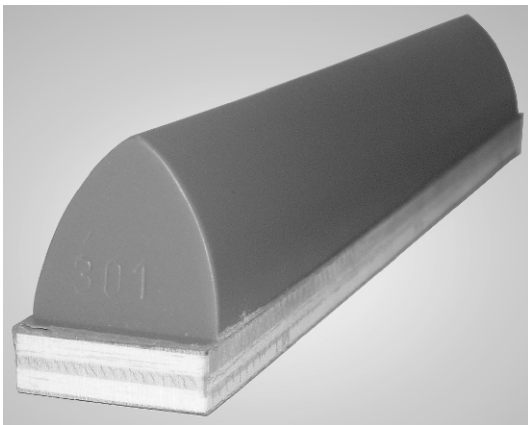

Nr. 3011 L 62 SL 50  
Nr. 3012 L 107 SL 95  
Nr. 3013 L 132 SL 119  
Nr. 831 L 144 SL 125  
Nr. 3014 L 162 SL 149  
Nr. 3015 L 212 SL 197  
Nr. 3016 L 256 SL 244

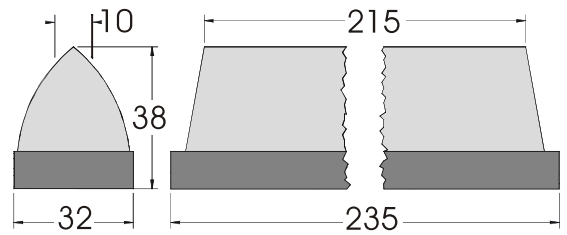

## Nr. 1916

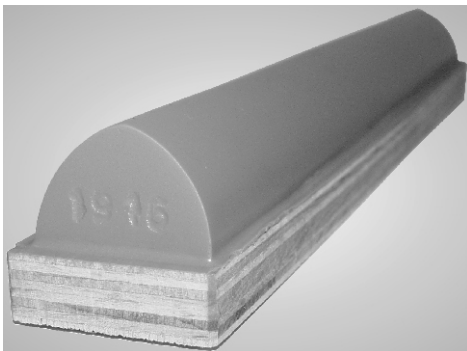

Nr. 1911 L 46 SL 30  
Nr. 1912 L 78 SL 60  
Nr. 1913 L 96 SL 80  
Nr. 1914 L 136 SL 119  
Nr. 1915 L 186 SL 167

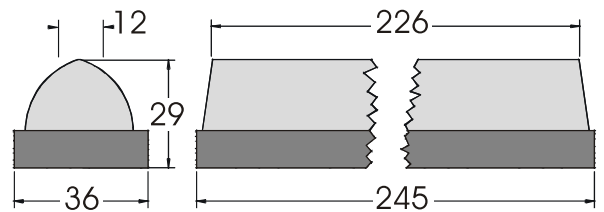

## Nr. 205

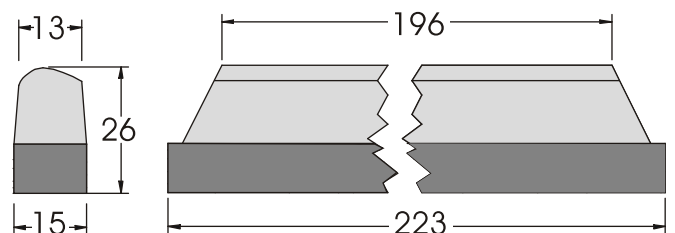
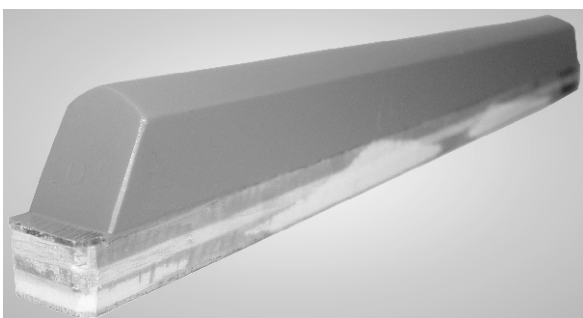

H = height  
L = length  
SL = silicone length

# LÜCK® TAMPON



## Nr. 708

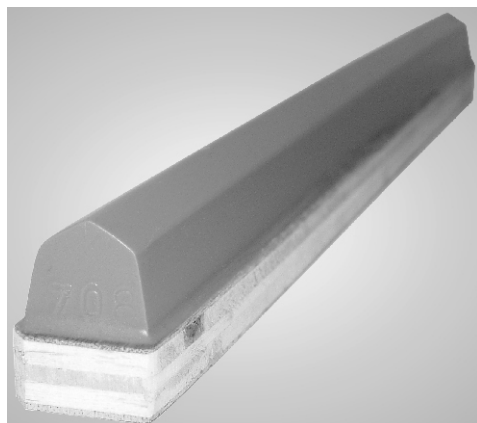

Nr. 7081 L 62 SL 50  
Nr. 7082 L 107 SL 95  
Nr. 7083 L 125 SL 116  
Nr. 7084 L 161 SL 150  
Nr. 7085 L 211 SL 200  
Nr. 7086 L 256 SL 245

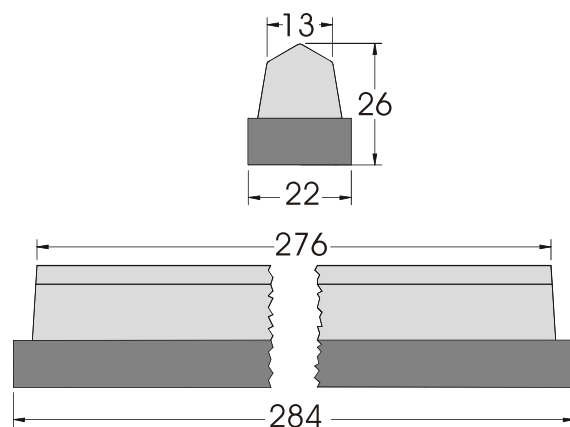

## Nr. 352

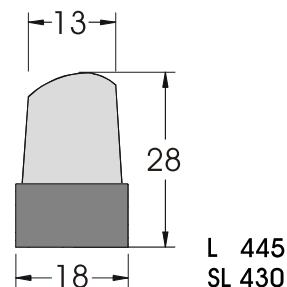
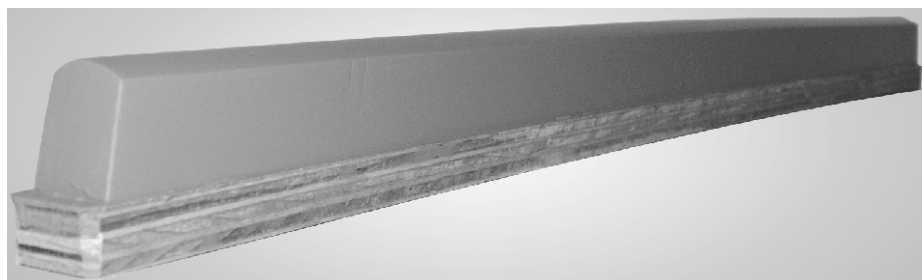

## Nr. 18

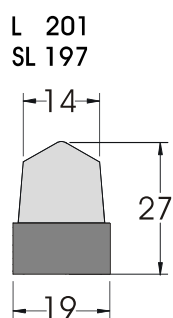
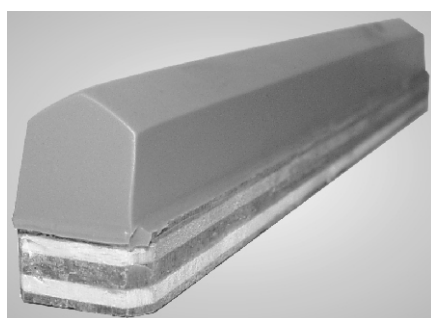

## Nr. 328

Nr. 3281 L 63 SL 50  
Nr. 328/60 L 70 SL 59  
Nr. 328/60 Alu M5 L 70 SL 59 H 23

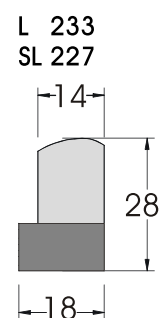
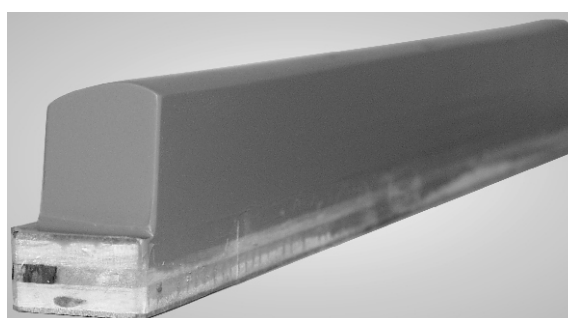

## Nr. 329

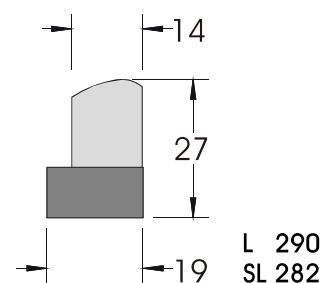
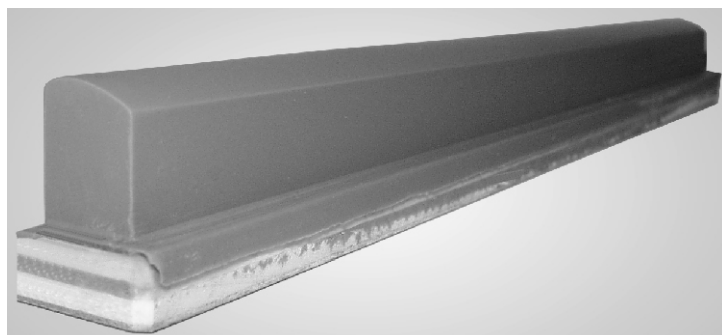



# LÜCK® TAMPON

H = Höhe  
L = Länge  
SL = Silikonlänge

Nr. 418

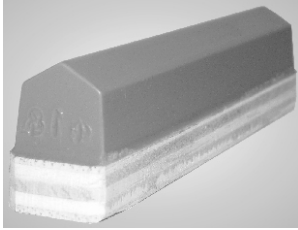

L 117  
SL 108

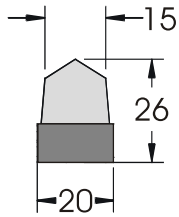

Nr. 206

Nr. 206/40  
Nr. 206/40 Alu 2xM6  
Nr. 206/100

L 54 SL 39  
L 54 SL 39 H 21  
L 109 SL 100

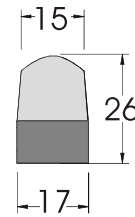
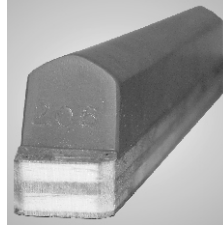

L 211  
SL 196

Nr. 712

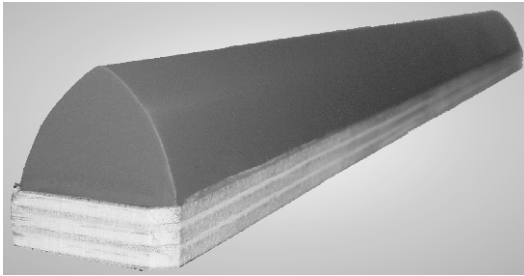

Nr. 7121 L 62 SL 50  
Nr. 7122 L 106 SL 94  
Nr. 7123 L 132 SL 120  
Nr. 7124 L 162 SL 150  
Nr. 7125 L 212 SL 200  
Nr. 7126 L 255 SL 244  
Nr. 7127 L 291 SL 282  
Nr. 7128 L 320 SL 310

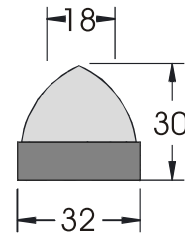

L 391  
SL 376

Nr. 74

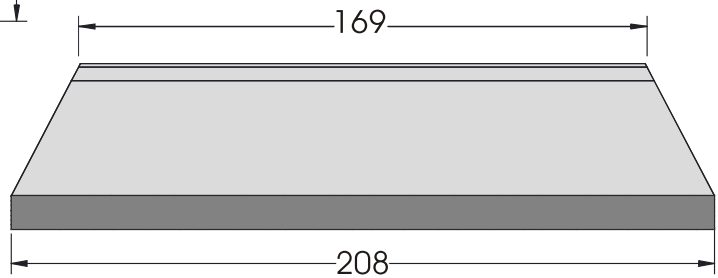
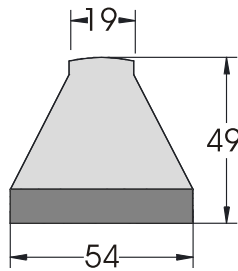
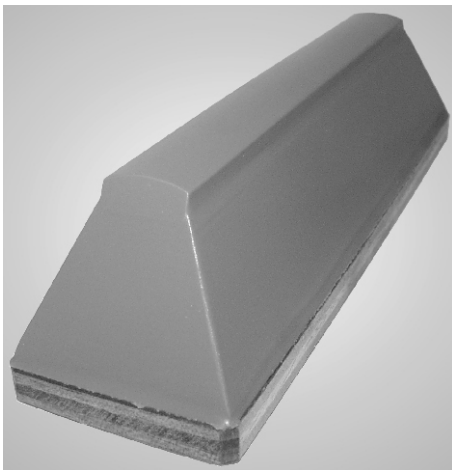

Nr. 207

Nr. 207/100 L 109 SL 100 H 26

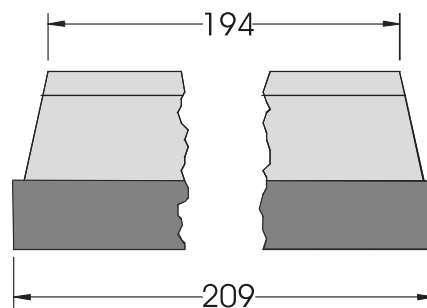
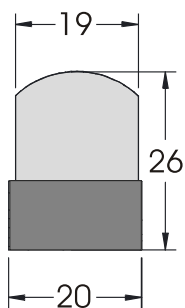
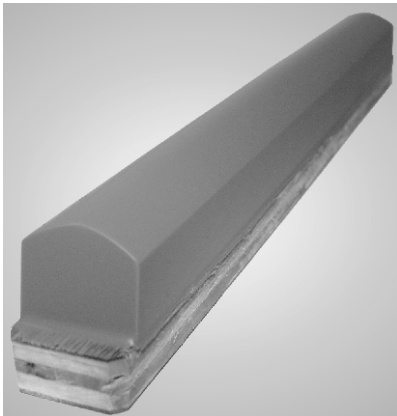



H = height  
 L = length  
 SL = silicone length

# LÜCK® TAMPON

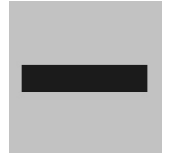

## Nr. 320

Nr. 320/26 L 55 SL 27  
 Nr. 320/45 L 55 SL 45

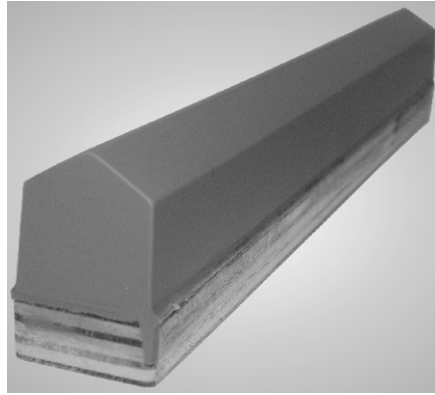

L 218  
 SL 213

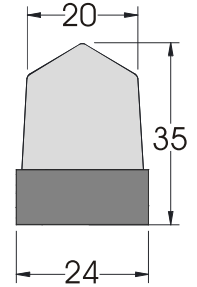

## Nr. 707

Nr. 7071 L 62 SL 50  
 Nr. 7072 L 108 SL 94  
 Nr. 7073 L 132 SL 120  
 Nr. 7074 L 162 SL 149  
 Nr. 7075 L 212 SL 197  
 Nr. 7076 L 258 SL 247  
 Nr. 7077 L 292 SL 283

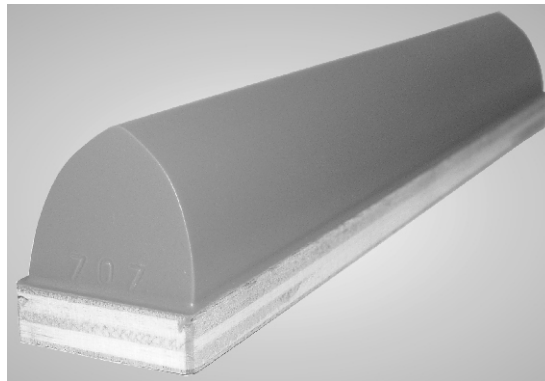

L 230  
 SL 214

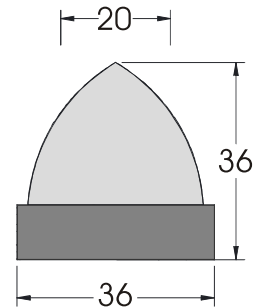

## Nr. 738

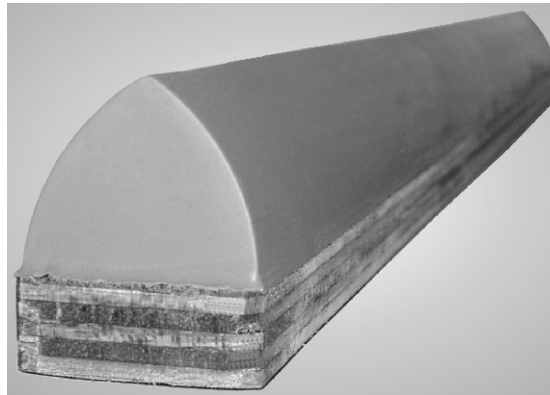

L 600  
 SL 590

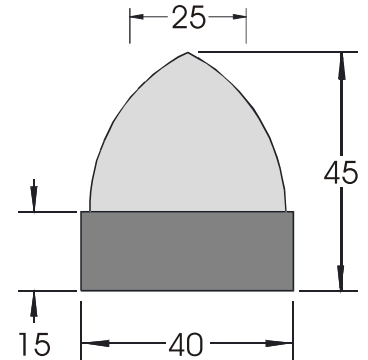

## Nr. 6167

Nr. 6161 L 63 SL 49  
 Nr. 6162 L 108 SL 94  
 Nr. 6163 L 132 SL 118  
 Nr. 6164 L 161 SL 148  
 Nr. 6165 L 212 SL 199  
 Nr. 6166 L 256 SL 244  
 Nr. 6168 L 360 SL 330

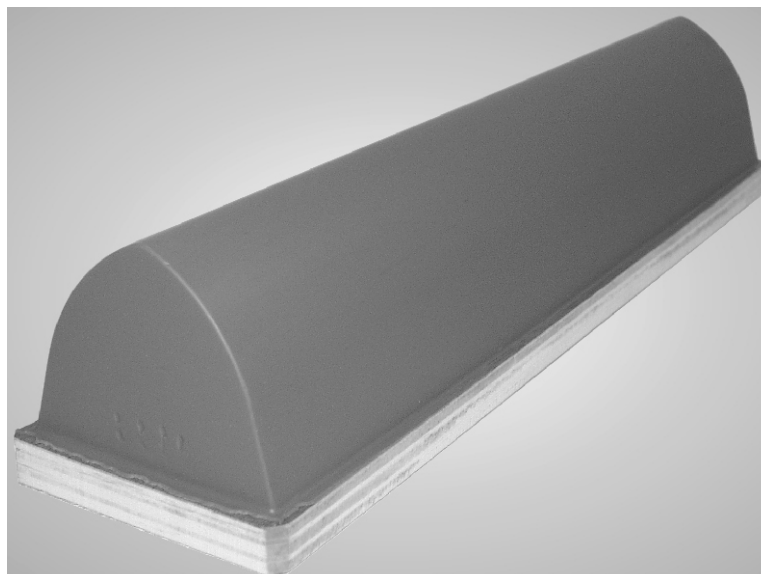

L 293  
 SL 283

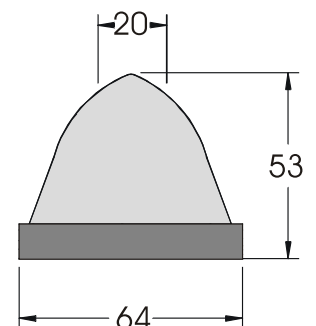



# LÜCK® TAMPON

H = Höhe  
L = Länge  
SL = Silikonlänge

Nr. 137

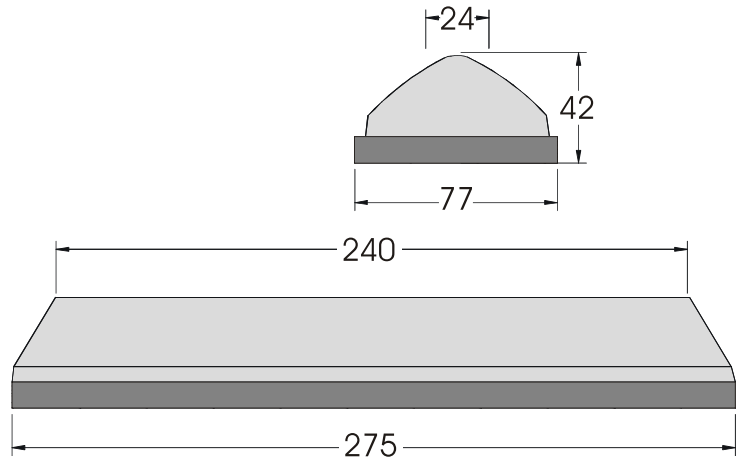
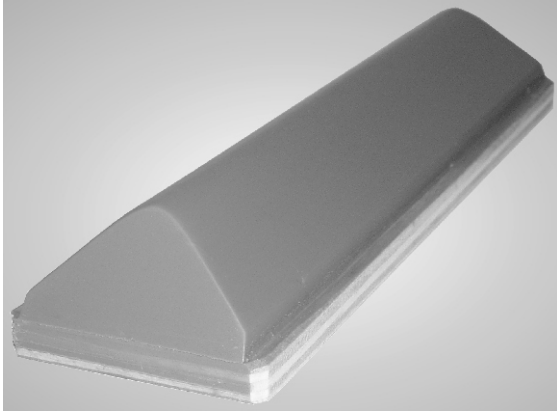

Nr. 610

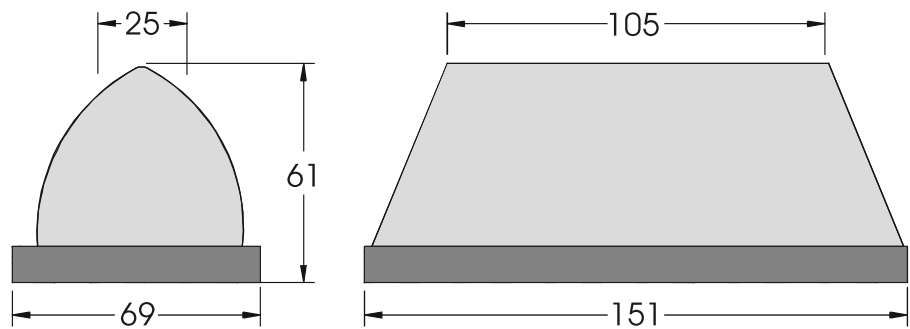
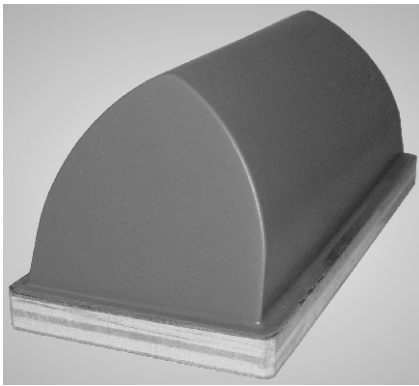

Nr. 1126

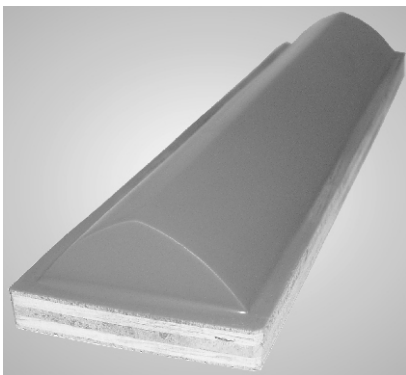

- Nr. 1121 L 45 SL 30
- Nr. 1122 L 75 SL 60
- Nr. 1123 L 95 SL 79
- Nr. 1124 L 134 SL 119
- Nr. 1125 L 183 SL 167

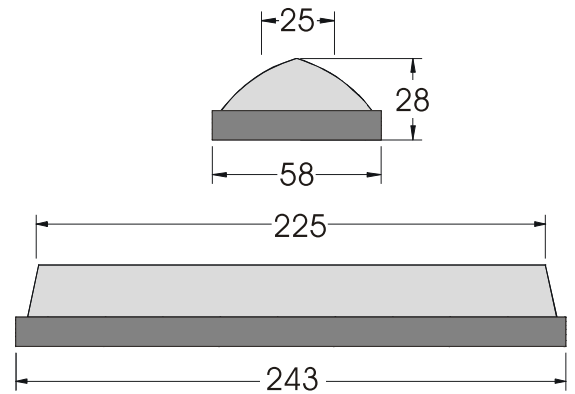

Nr. 233

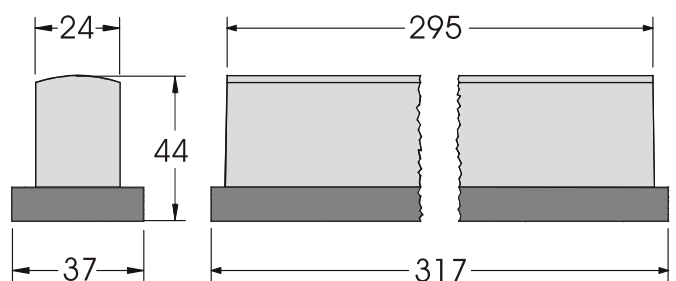
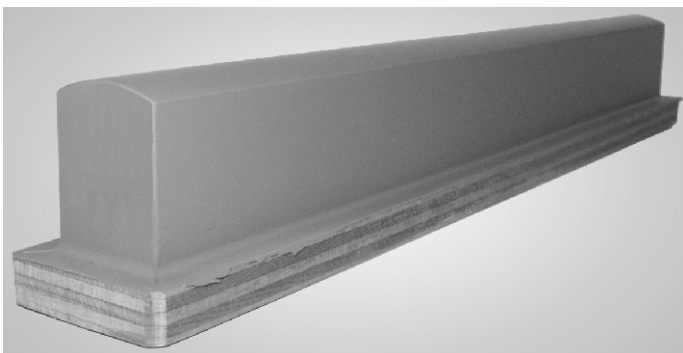

H = height  
L = length  
SL = silicone length

# LUCK<sup>®</sup>

## TAMPON



### Nr. 228

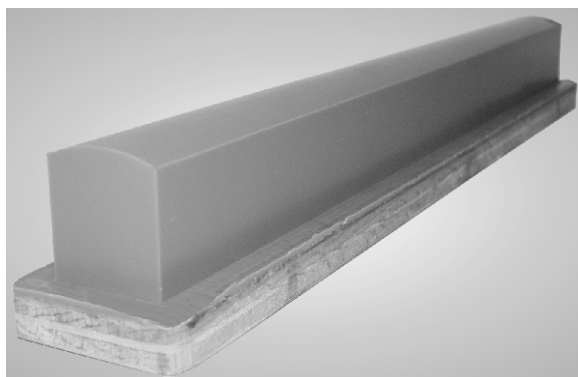

L 316  
SL 298

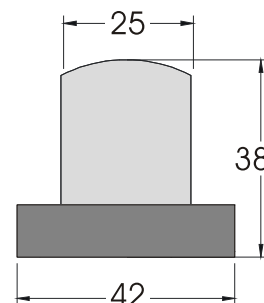

### Nr. 230

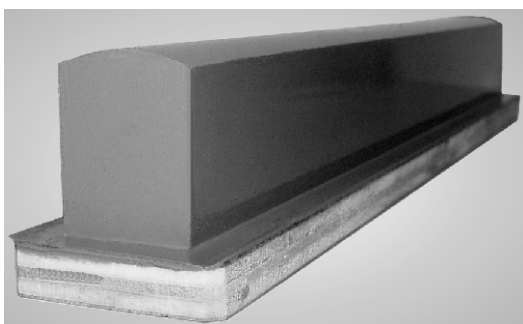

L 314  
SL 298

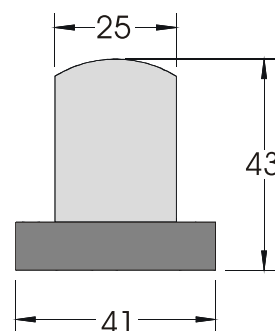

### Nr. 229

Nr. 229 Alu 2xM6 H 30

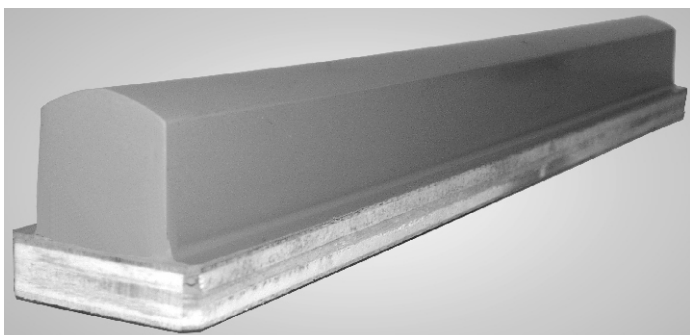

L 315  
SL 312

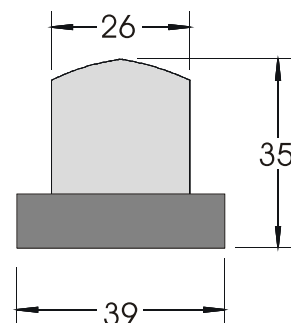

### Nr. 706

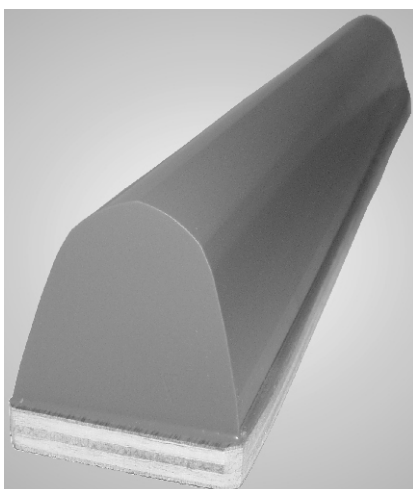

- Nr. 700 L 83 SL 56
- Nr. 701 L 130 SL 99
- Nr. 702 L 160 SL 128
- Nr. 703 L 185 SL 154
- Nr. 704 L 225 SL 194
- Nr. 705 L 293 SL 261
- Nr. 7001 L 58 SL 50
- Nr. 7002 L 103 SL 95
- Nr. 7003 L 129 SL 120
- Nr. 7004 L 159 SL 149
- Nr. 7005 L 207 SL 197
- Nr. 7006 L 255 SL 245
- Nr. 7007 L 291 SL 283

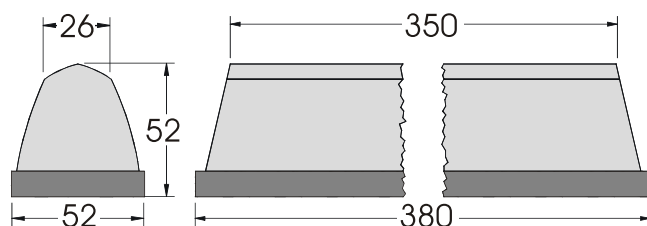



# LÜCK® TAMPON

H = Höhe  
 B = Breite  
 L = Länge  
 SL = Silikonlänge  
 SB = Silikonbreite

## Nr. 713

- Nr. 7131 L 63 SL 50
- Nr. 7132 L 108 SL 95
- Nr. 7133 L 132 SL 119
- Nr. 7134 L 162 SL 149
- Nr. 7135 L 212 SL 197
- Nr. 7136 L 257 SL 247
- Nr. 7137 L 291 SL 282
- Nr. 713/100 L 111 SL 100

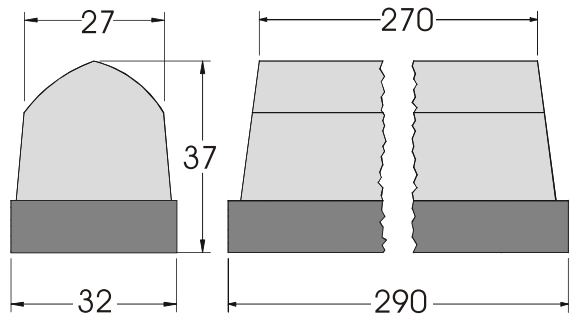
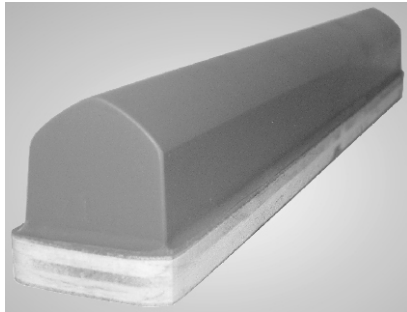

## Nr. 264

- Nr. 64**  
L 127 SL 124 B 37 SB 26 H 44
- Nr. 64/20 Alu M6**  
L 25 SL 20 B 37 SB 26 H 39
- Nr. 64/40 Alu M6**  
L 45 SL 40 B 37 SB 26 H 39
- Nr. 64/55 Alu M6**  
L 59 SL 55 B 37 SB 26 H 39
- Nr. 64/75 Alu M6**  
L 77 SL 75 B 37 SB 26 H 39
- Nr. 64/75**  
L 77 SL 75 B 37 SB 26 H 44

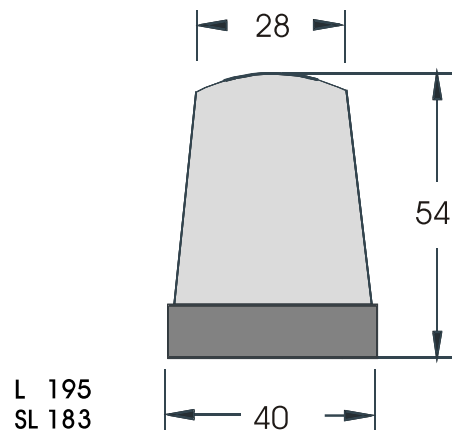
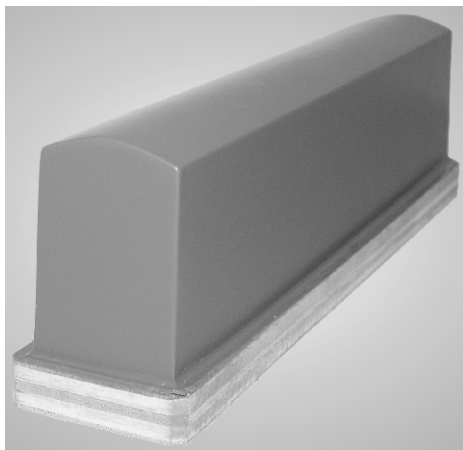

## Nr. 77

- Nr. 75 L 164 SL 137
- Nr. 76 L 210 SL 182

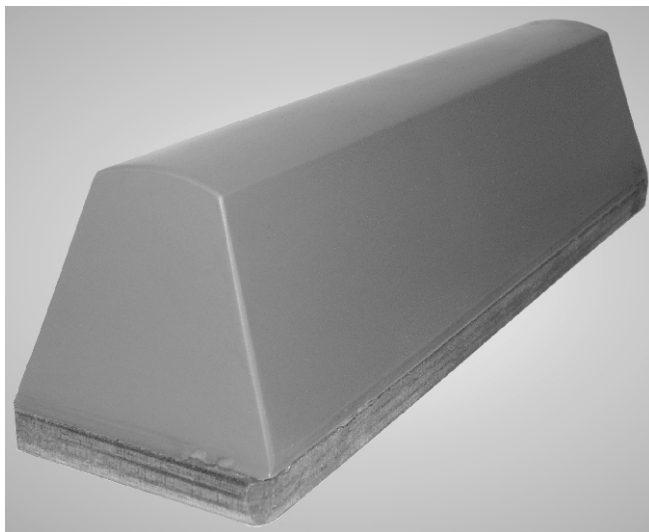

L 264  
 SL 236

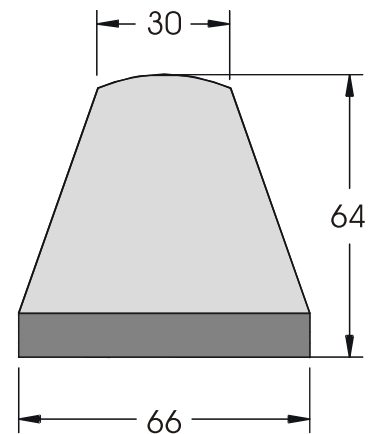

## Nr. 660

- Nr. 66 L 128 SL 120
- Nr. 66/25 L 34 SL 24
- Nr. 66/55 L 64 SL 55

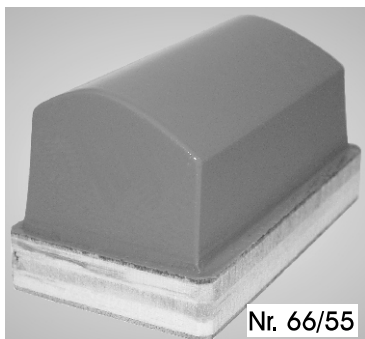

Nr. 66/55

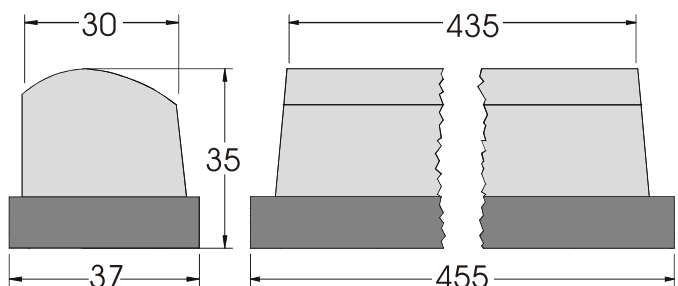

H = height  
 B = width  
 L = length  
 SL = silicone length  
 SB = silicone width

**LÜCK®**  
**TAMPON**

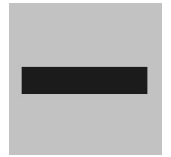

Nr. 1229

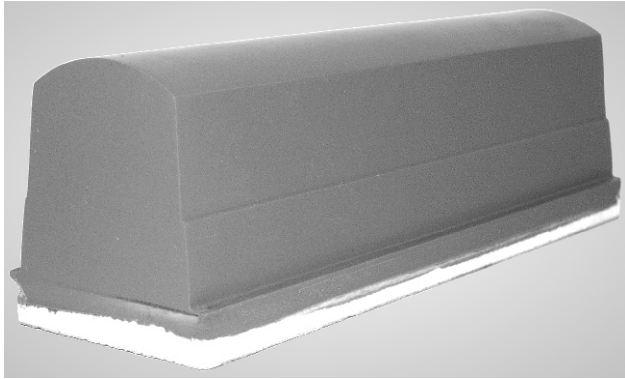

L 150  
 SL 145

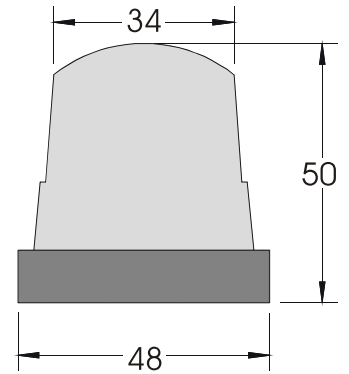

Nr. 65

Nr. 65 K L 196 SL 185 B 43 H 40  
 Nr. 65/120 L 142 SL 120 B 50 H 67  
 Nr. 65K/120 L 130 SL 120 B 43 H 40

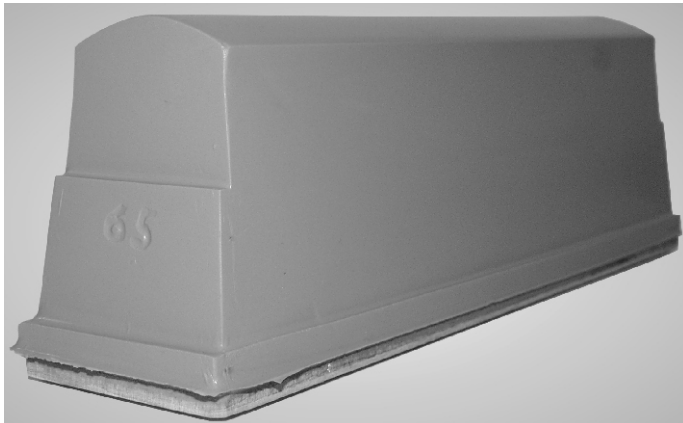

L 208  
 SL 185

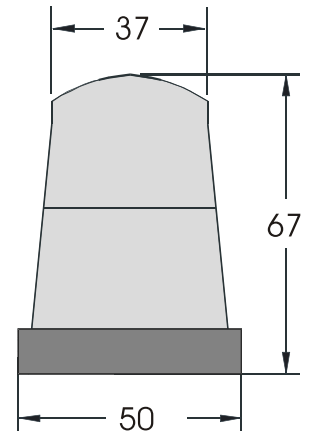

Nr. 353

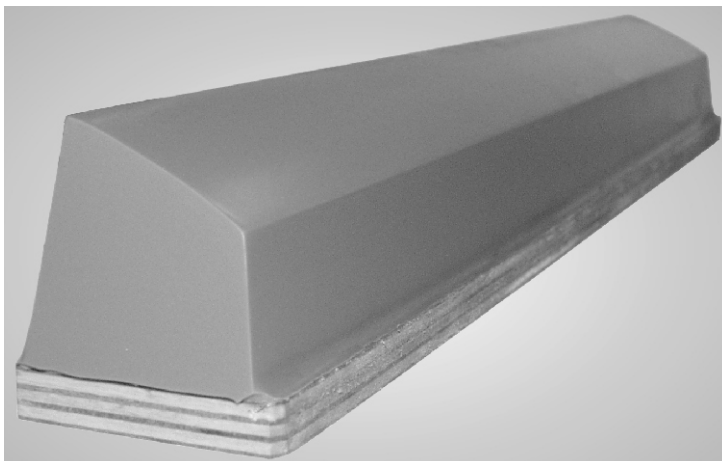

L 445  
 SL 430

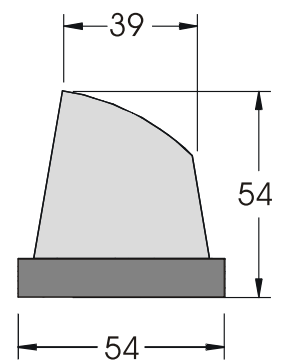



# LÜCK® TAMPON

H = Höhe  
L = Länge  
SL = Silikonlänge  
SB = Silikonbreite

## Nr. 1136

Nr. 1131 L 54 SL 29  
Nr. 1132 L 65 SL 59  
Nr. 1133 L 105 SL 79  
Nr. 1134 L 145 SL 120  
Nr. 1135 L 195 SL 169

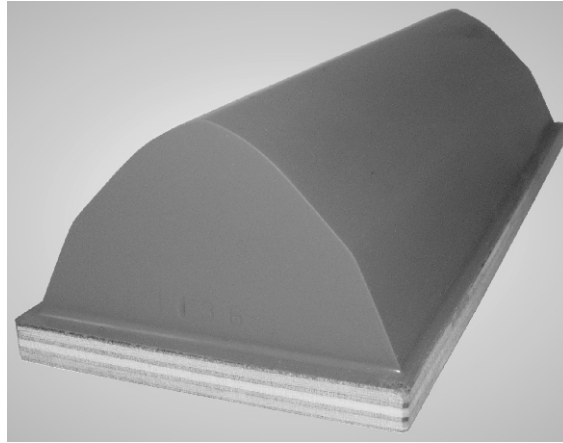

L 254  
SL 230

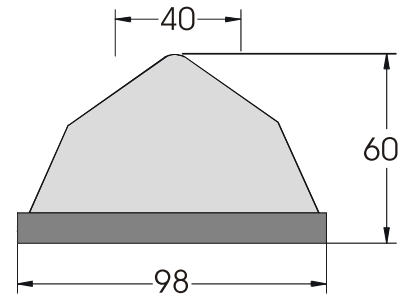

## Nr. 740/450

Nr. 7401 L 64 SL 49 H 51  
Nr. 7402 L 108 SL 94 H 51  
Nr. 7403 L 132 SL 119 H 51  
Nr. 7404 L 162 SL 149 H 51  
Nr. 7405 L 212 SL 199 H 51  
Nr. 7406 L 247 SL 243 H 51  
Nr. 7407 L 292 SL 282 H 51  
Nr. 740 L 345 SL 320 H 60

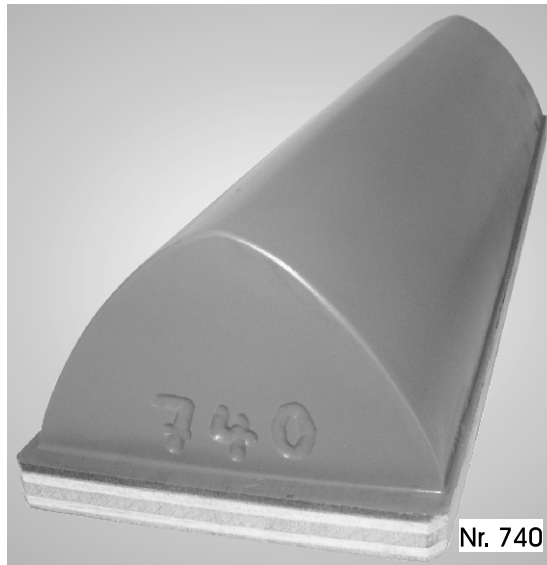

L 480  
SL 447

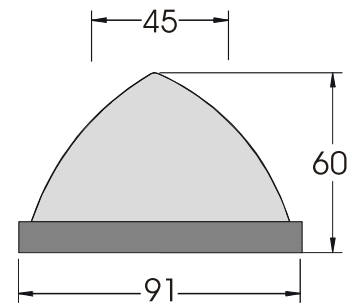

## Nr. 62

Nr. 62/110 L 138 SL 110  
Nr. 62/50 L 78 SL 50

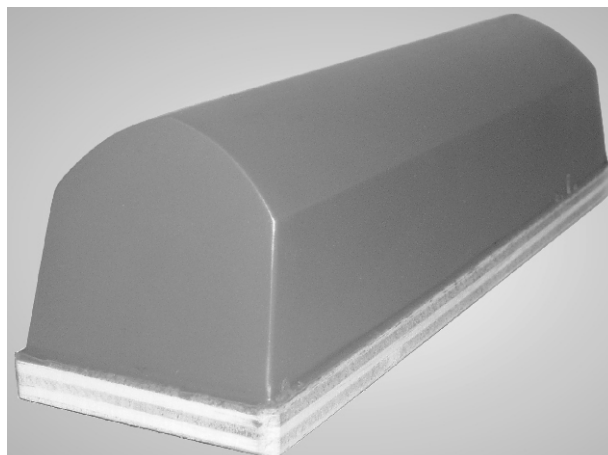

L 208  
SL 185

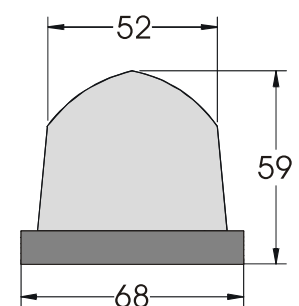

H = height  
 L = length  
 SL = silicone length  
 SB = silicone width

# LÜCK® TAMPON

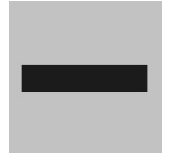

## Nr. 63

Nr. 6301 L 63 SL 47 H 53  
 Nr. 6302 L 108 SL 95 H 53  
 Nr. 6303 L 132 SL 117 H 53  
 Nr. 6304 L 161 SL 147 H 53  
 Nr. 6305 L 212 SL 197 H 53  
 Nr. 6306 L 257 SL 243 H 53  
 Nr. 6307 L 293 SL 283 H 53  
 Nr. 6308 L 367 SL 330 H 53  
 Nr. 6309 L 400 SL 378 H 53

Nr. 63/65 L 104 SL 64  
 Nr. 63/115 L 153 SL 114  
 Nr. 63/130 L 141 SL 129  
 Nr. 63/220 L 236 SL 219  
 Nr. 763 L 298 SL 254

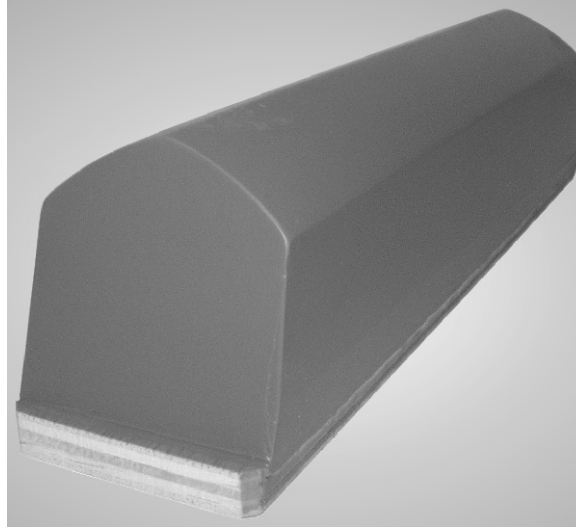

L 235  
 SL 270

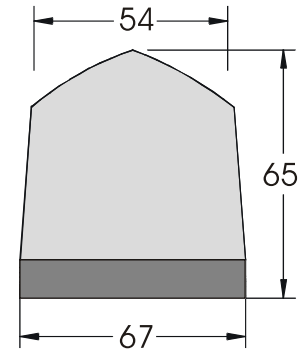

## Nr. 7370

Nr. 7371 SB 60 SL 228  
 Nr. 7372 L 160 SL 140

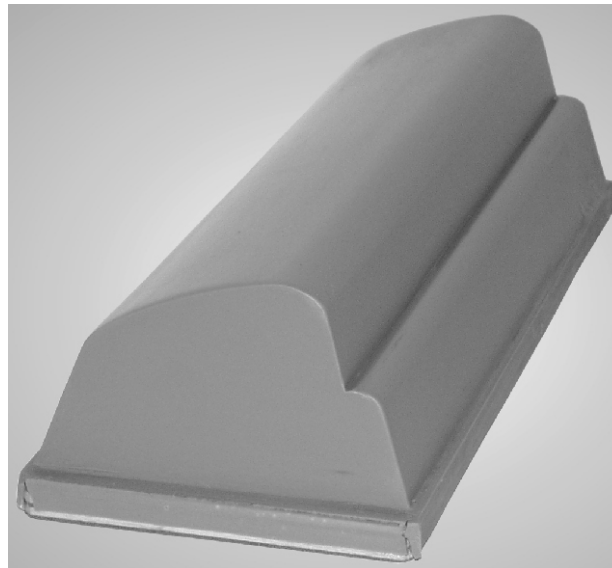

L 246  
 SL 230

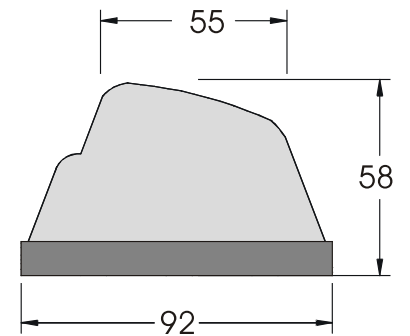

## Nr. 359

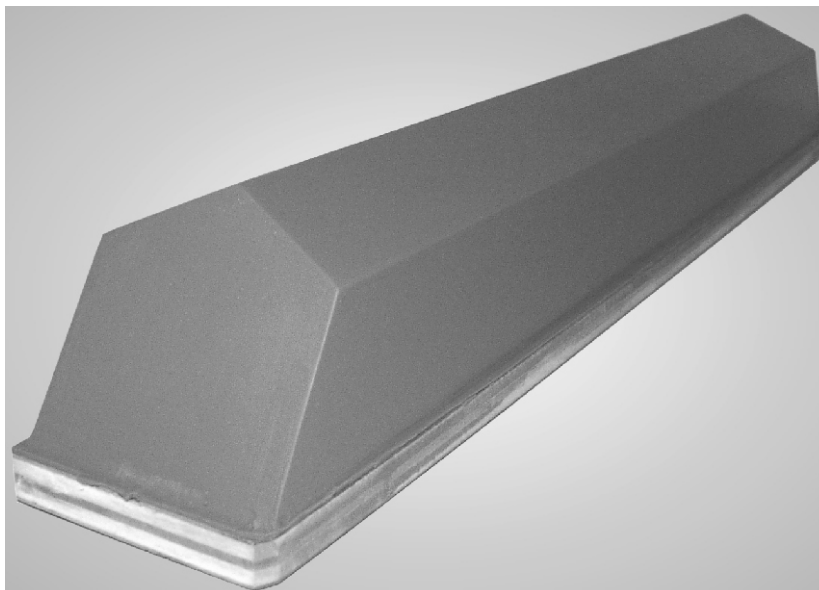

L 405  
 SL 339

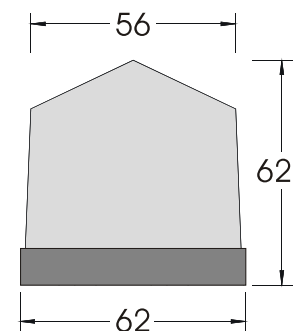



# LÜCK® TAMPON

H = Höhe  
B = Breite  
L = Länge  
SL = Silikonlänge

## Nr. 256

Nr. 256K L 230 B 74 H 55

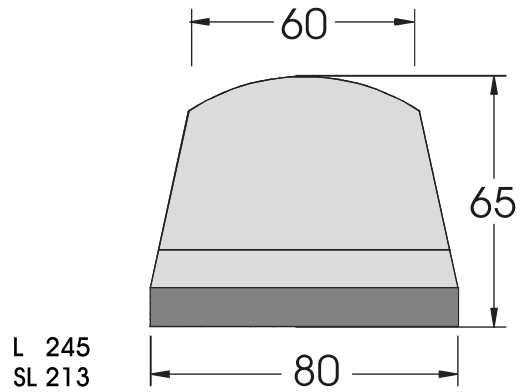
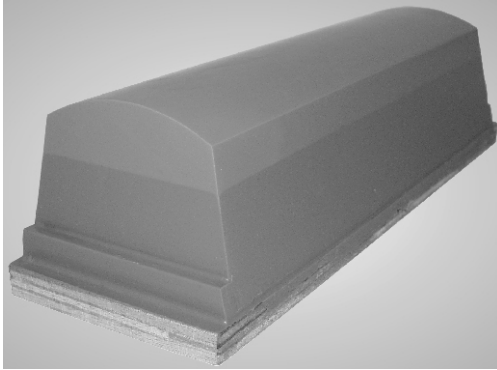

## Nr. 355

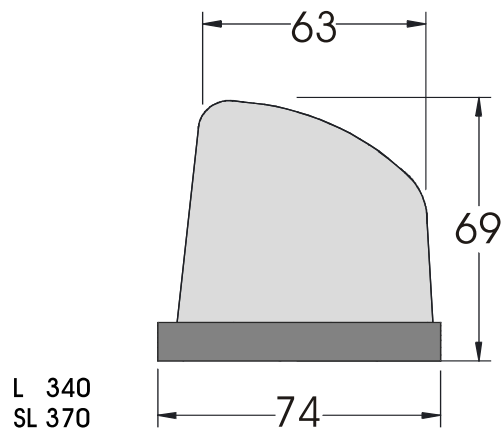
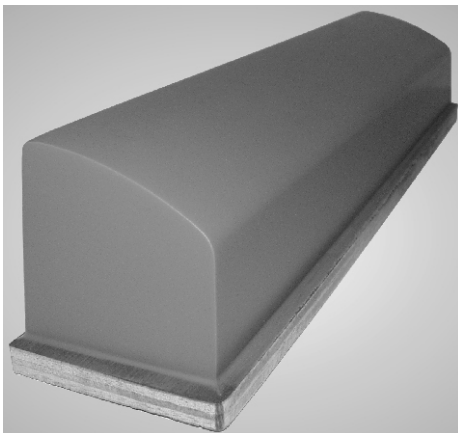

## Nr. 257

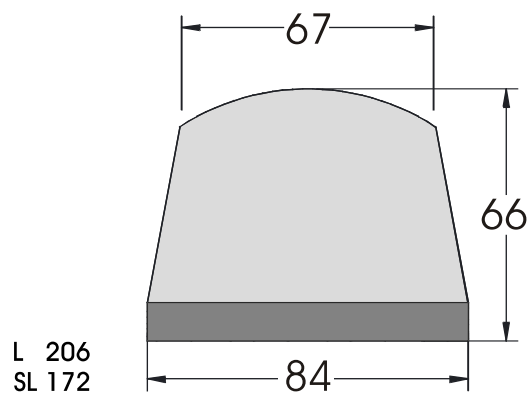
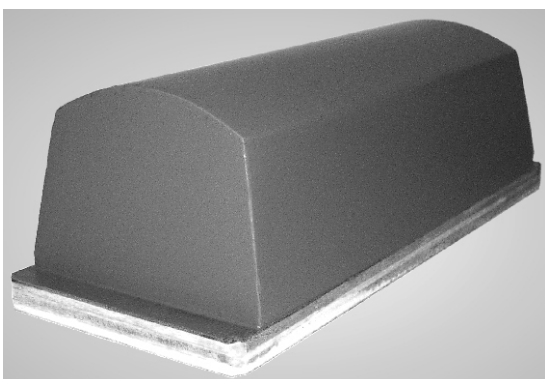



H = height  
B = width  
L = length  
SL = silicone length

# LÜCK®

## TAMPON

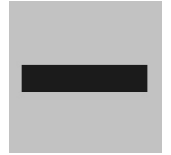

### Nr. 251/390

Nr. 251/305 L 343 SL 305

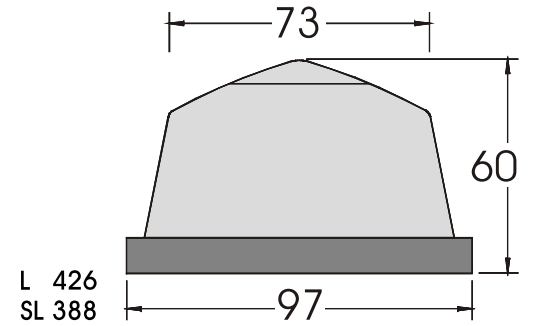
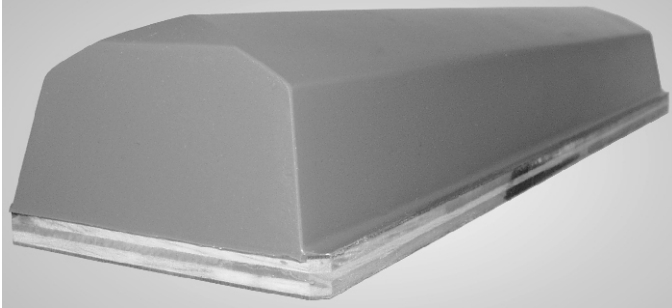

### Nr. 354

Nr. 354K L 312 SL 267

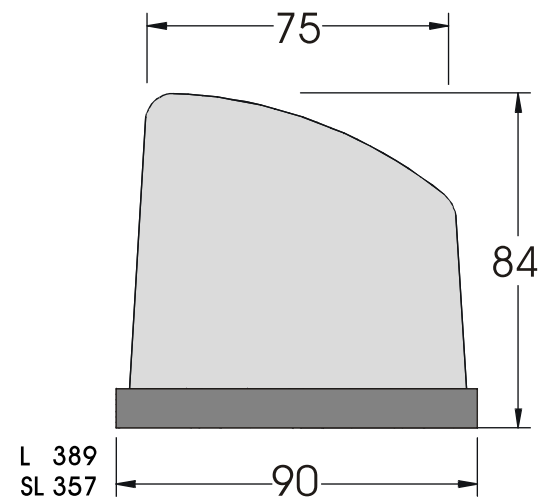
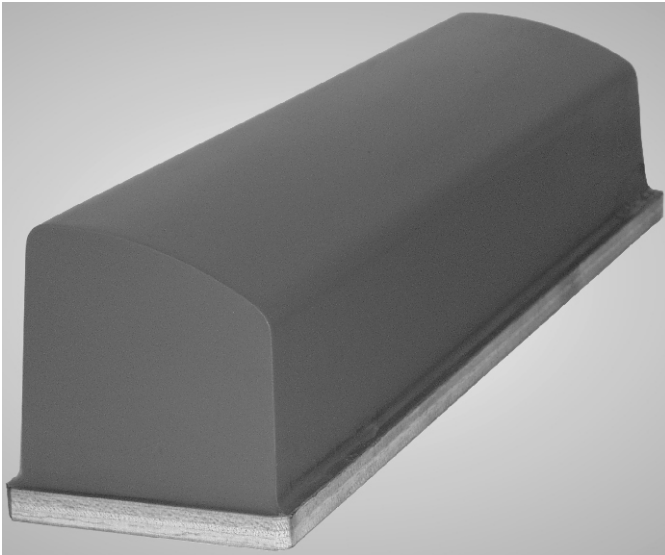

### Nr. 360

Nr. 360K H 65  
Nr. 360/80 H 80

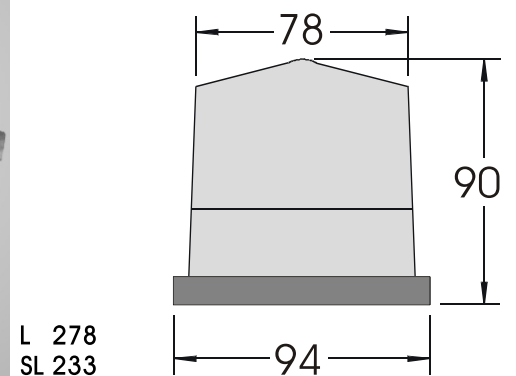
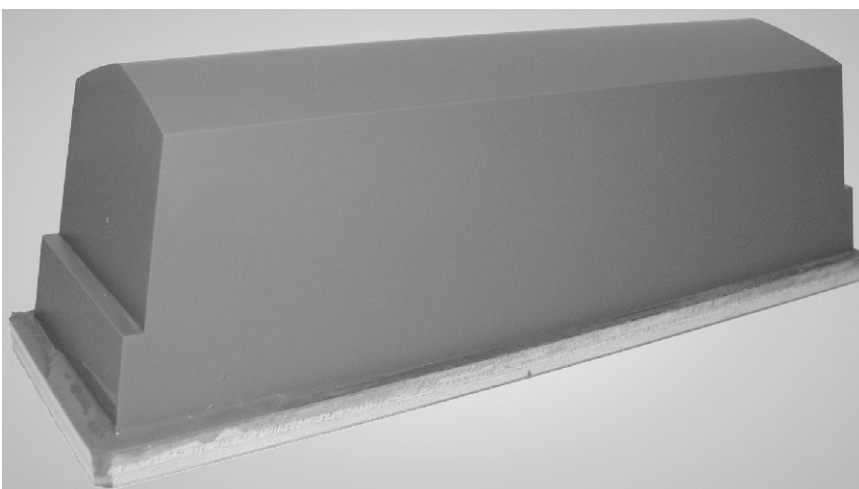



# LÜCK® TAMPON

H = Höhe  
B = Breite  
L = Länge  
SL = Silikonlänge

## Nr. 250

Nr. 250/130/65	L 140	B 110	H 65	SL 127
Nr. 250/130/105	L 150	B 138	H 104	SL 127
Nr. 250/190/65	L 200	B 110	H 65	SL 190
Nr. 250/190/105	L 210	B 138	H 105	SL 190
Nr. 250/250/65	L 270	B 110	H 65	SL 247
Nr. 250/250/105	L 300	B 138	H 104	SL 247
Nr. 250/280/105	L 310	B 138	H 104	SL 280
Nr. 250/380/105	L 410	B 138	H 104	SL 380

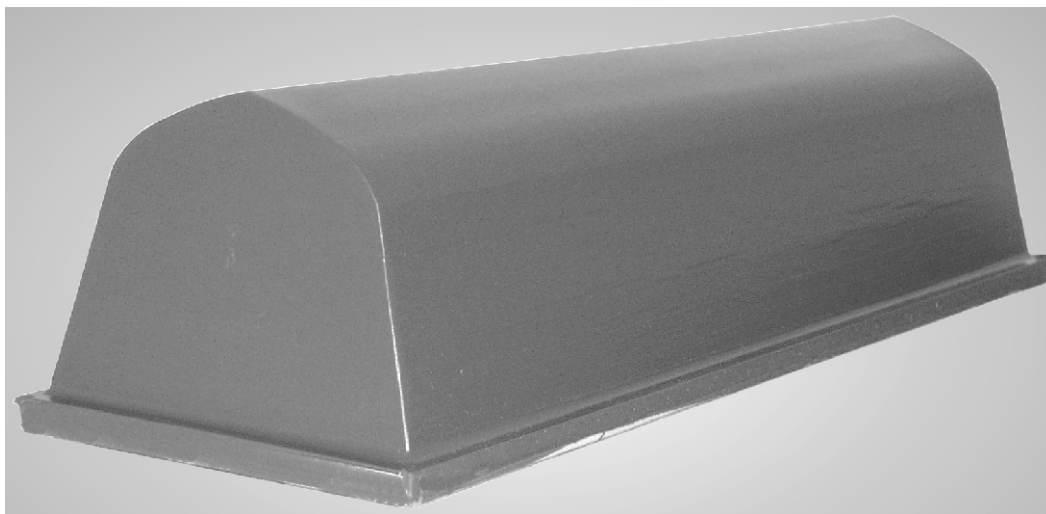
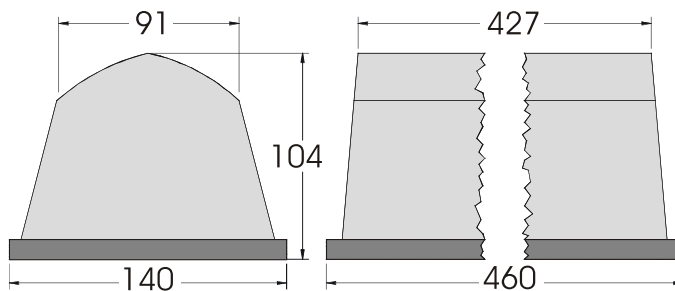

## Nr. 500

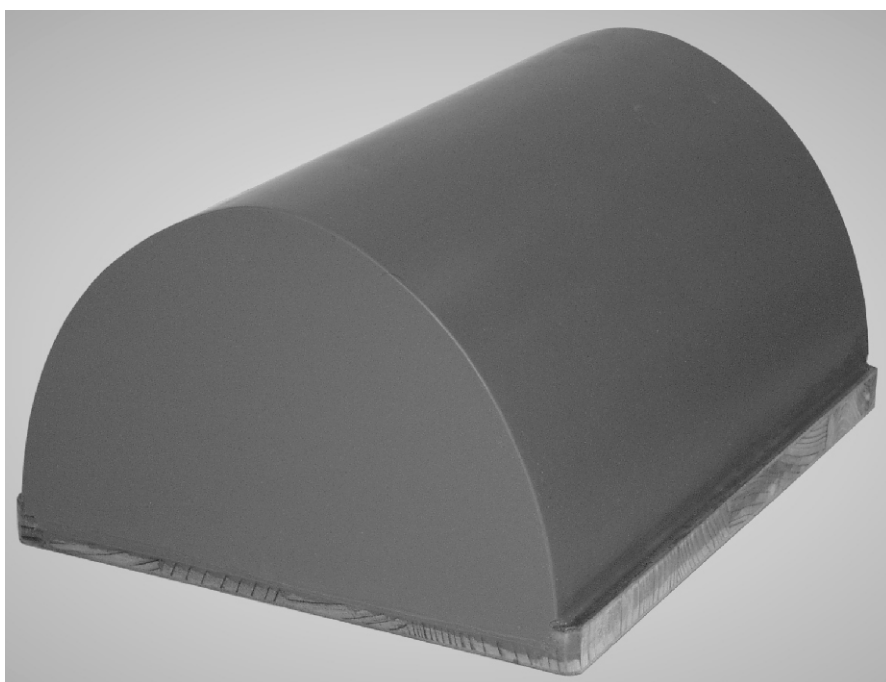

L 248  
SL 248

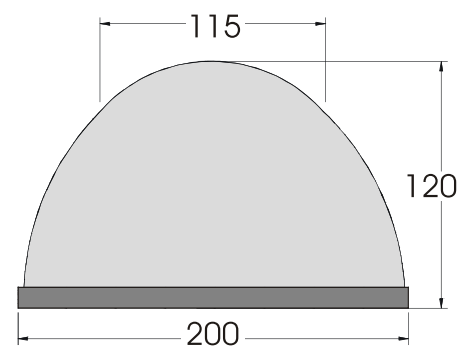

H = height  
B = width  
L = length  
SL = silicone length

# LÜCK® TAMPON

# S

Nr. 2028 Alu

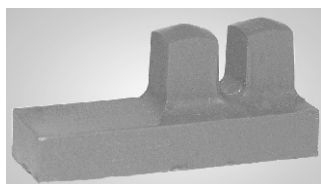

L 30 B 10 H 13

Nr. 2029

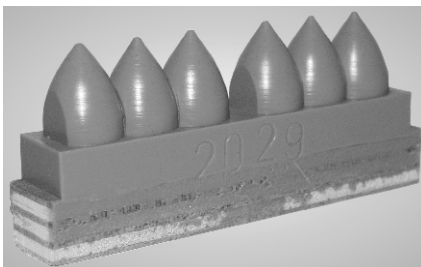

L 77 B 14 H 32

Nr. 2023 Alu M6

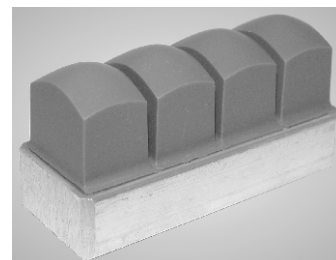

L 50 B 20 H 25

Nr. 19D

Nr. 19D Alu M6 H 25



L 52 B 25 H 30

Nr. 594

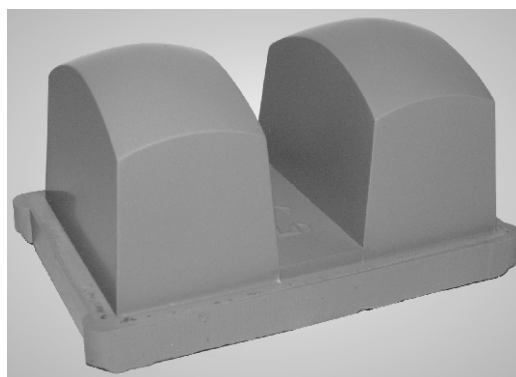

L 93 B 62 H 51

Nr. 276

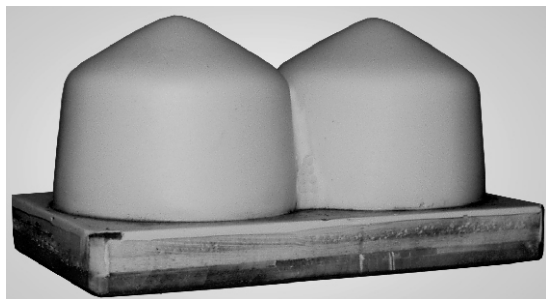

L 89 B 54 H 44

Nr. 87

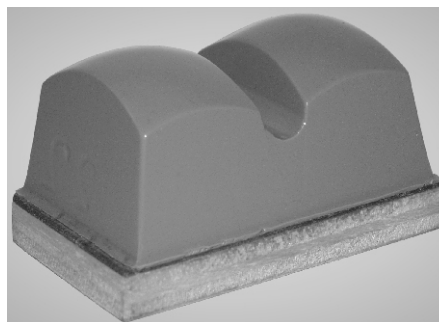

L 70 B 52 H 39

Nr. 596

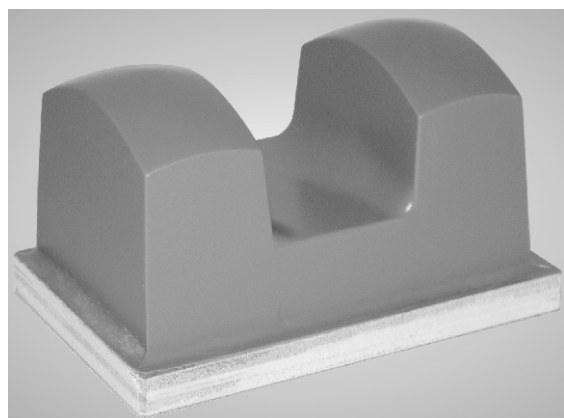

L 108 B 70 H 62

Nr. 28D

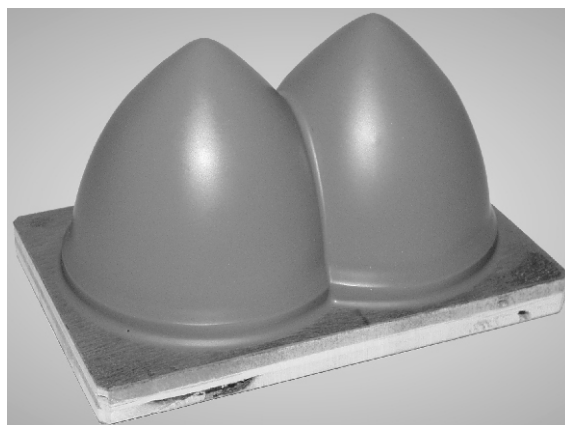

L 108 B 69 H 63

**S**

**LÜCK®  
TAMPON**

H = Höhe  
B = Breite  
L = Länge  
S = Silikon  
SB = Silikonbreite

Nr. 1M

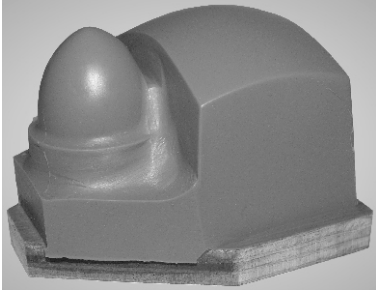

L 84 B 72 H 57

Nr. 89D

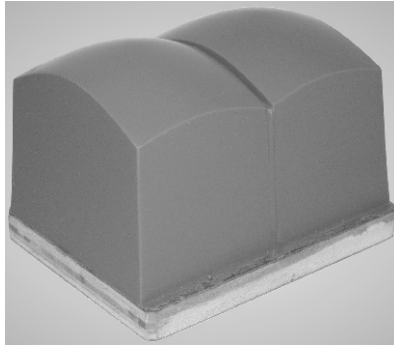

L 93 B 72 H 64

Nr. 430D

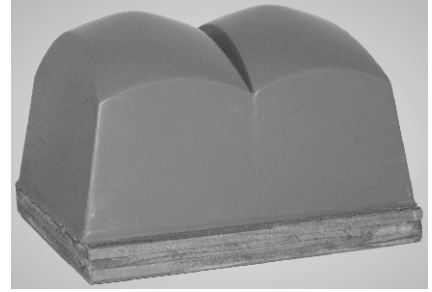

L 89 B 81 H 61

Nr. 593S

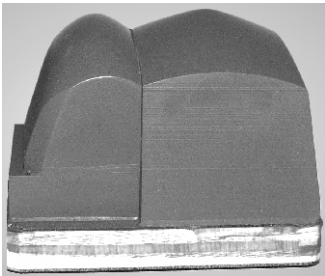

L 68 B 55 H 51

Nr. 593

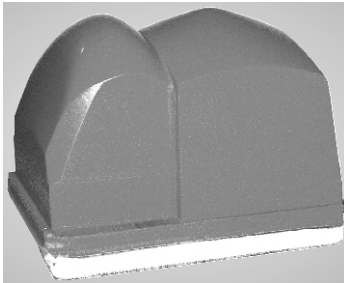

L 66 B 56 H 51

Nr. 641

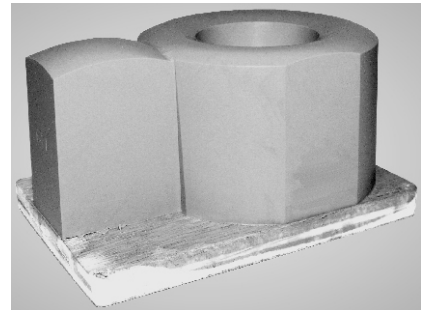

L 110 B 73 H 58

Nr. 640

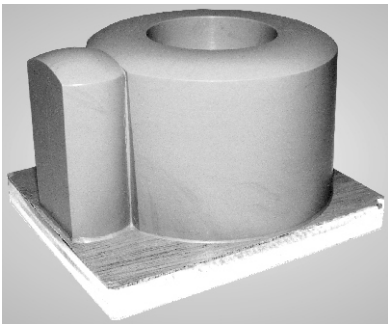

L 94 B 80 H 59

Nr. 801

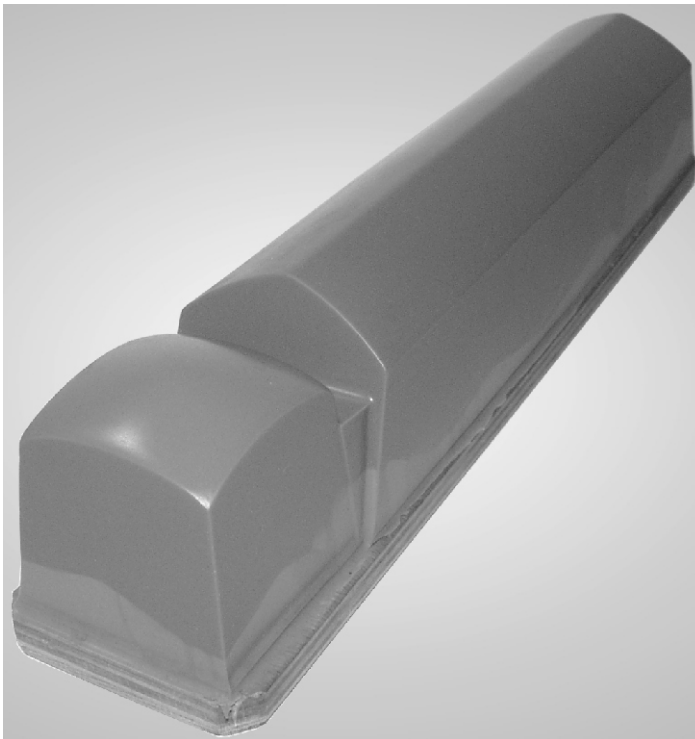

L 325 B 66 H 66

H = height Loch = hole  
 B = width Rand = edge  
 L = length hohl = hollow  
 S = silicone  
 SB = silicone width

# LÜCK® TAMPON

S

Nr. 548

Nr. 648 SB 19

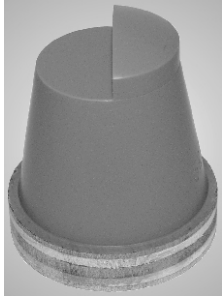

ØS27 H 50 SB 13

Nr. 520



ØS29 H 35 Loch Ø15

Nr. 671



ØS34 H 35 Loch Ø28

Nr. 674



ØS35 H 39 Loch Ø19

Nr. 672



ØS36 H 40 Rand 3

Nr. 673



ØS37 H 35 Rand 5

Nr. 675



ØS37 H 39 Loch Ø21

Nr. 547

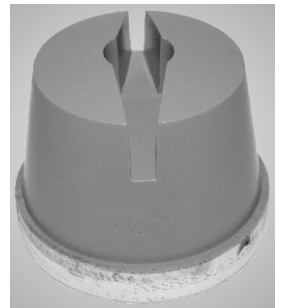

ØS44 H 45

Nr. 646



ØS35 H 58 Loch Ø13

Nr. 670



ØS38 H 58 Loch Ø30

Nr. 668



ØS48 H 50

Nr. 667



ØS50 H 53 Loch Ø35

Nr. 465 hohl

auf Ring-Alu mit 2xM6



ØS53 H 58

Nr. 466L hohl

auf Ring-Alu mit 2xM6



ØS52 H 50

Nr. 467L hohl

auf Ring-Alu mit 2xM6

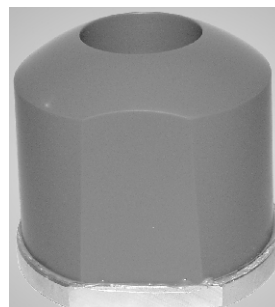

ØS54 H 51 Loch Ø26

Nr. 468L hohl

auf Ring-Alu mit 2xM6



ØS55 SB48 H 52

**S**

# LÜCK® TAMPON

H = Höhe  
S = Silikon

Nr. 46L23



S Ø54 H 46 Loch Ø23

Nr. 546S

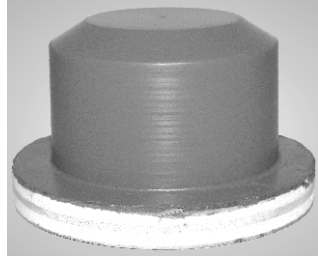

S Ø57 H 47

Nr. 669

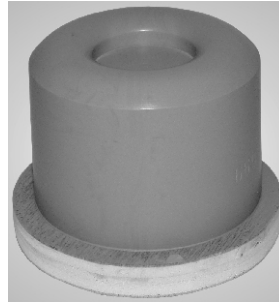

S Ø57 H 53 Loch Ø26

Nr. 676



S Ø45 H 47 Loch Ø28

Nr. 45S16

Nr. 45S13 Nut 13x34 H45

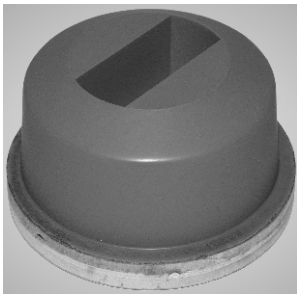

S Ø62 H 43 Nut 16x40

Nr. 809



S Ø62 H 68 Nut 12x40

Nr. 644

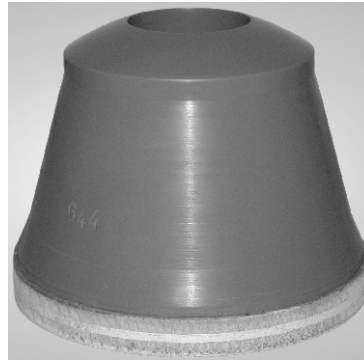

S Ø62 H 70 Loch Ø30

Nr. 44S22

Nr. 44S17 H 49 Nut 17



S Ø64 H 52 Nut 22

Nr. 544

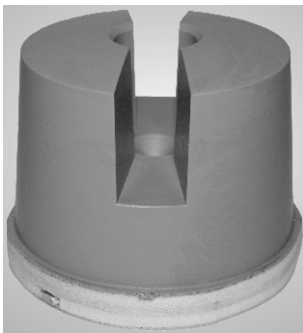

S Ø64 H 59 Innenloch Ø21

Nr. 846S



S Ø70 H 60

Nr. 846

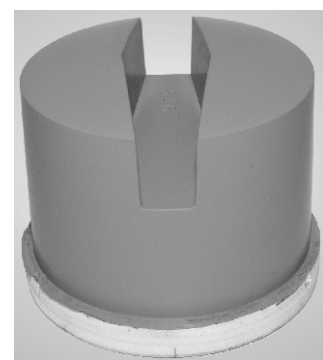

S Ø70 H 60

Nr. 639S

Nr. 639 flacherer Radius



S Ø72 H 57 Loch Ø37

Nr. 843



S Ø78 H 59 Loch Ø23

Nr. 814



S Ø81 H 58 Loch Ø48

H = height Loch= hole  
 S = silicone Nut= groove  
 Schlitz= slit  
 Fläche= plane

**LÜCK®**  
**TAMPON**

**S**

Nr. 811



S Ø81 H 72 Schlitz 10x34

Nr. 810



S Ø81 H 72 Schlitz 10x40

Nr. 808



S Ø81 H 72 Schlitz 11x35

Nr. 643

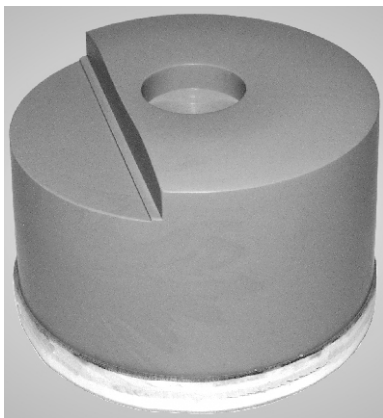

S Ø81 H 59 Loch Ø23

Nr. 643S



S Ø81 H 59 Loch Ø23

Nr.804



S Ø94 H 63

Nr. 513

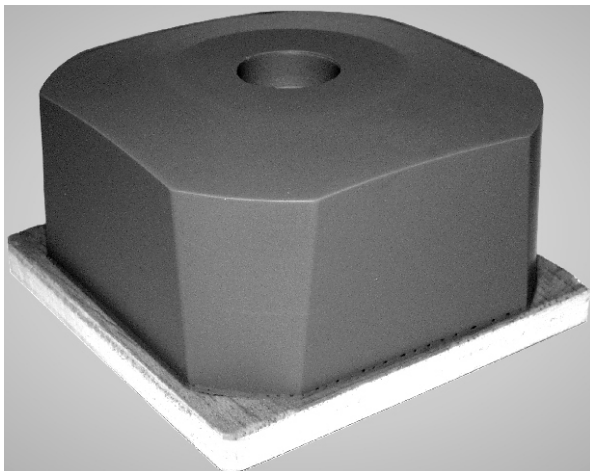

S Ø97 H 58 Fläche Ø54 Loch Ø23

Nr. 805

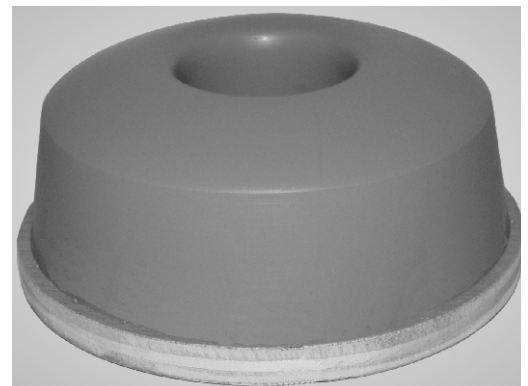

S Ø103 H 51 Loch Ø34

**S**

# LÜCK® TAMPON

H = Höhe  
S = Silikon

Nr. 807



S ø103 H 72 Loch ø33

Nr. 507



S ø105 H 85 Loch ø63

Nr. 818

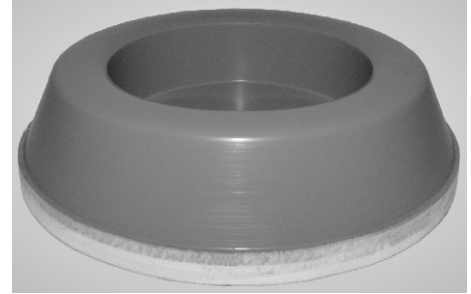

S ø111 H 36 Loch ø79

Nr. 903

Nr. 903 Alu

S ø115  
H 90  
abgeflacht



Nr. 157

S ø117  
H 92  
abgeflacht



Nr. 902

S ø118  
H 92  
abgeflacht



Nr. 802

S ø123  
H 60



Nr. 803

S ø130  
H 77  
Loch ø78



Nr. 800

S ø135  
H 78  
Loch ø67





H = height Loch = hole  
S = silicon  
abgeflacht = flattened

# LÜCK®

## TAMPON

# S

Nr. 512

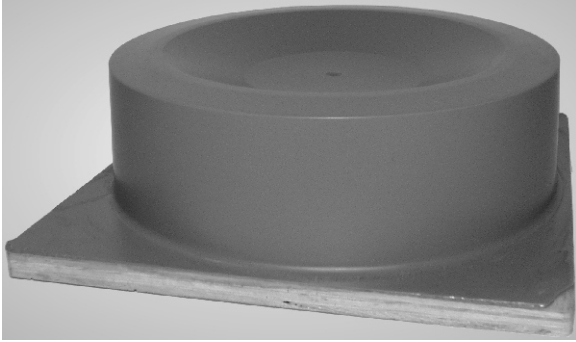

S  $\varnothing$ 167 H 61 Loch  $\varnothing$  130-70

Nr. 822

Nr. 823 S  $\varnothing$  207 H 62 Loch  $\varnothing$ 136

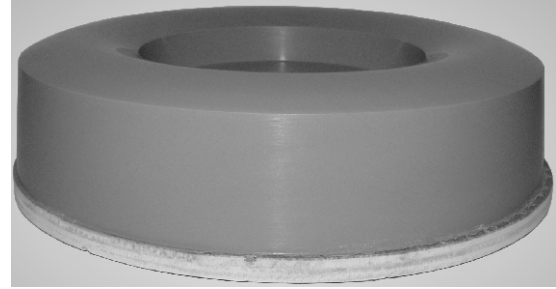

S  $\varnothing$  220 H 63 Loch  $\varnothing$ 123

Nr. 303

Nr. 304 Loch  $\varnothing$ 135

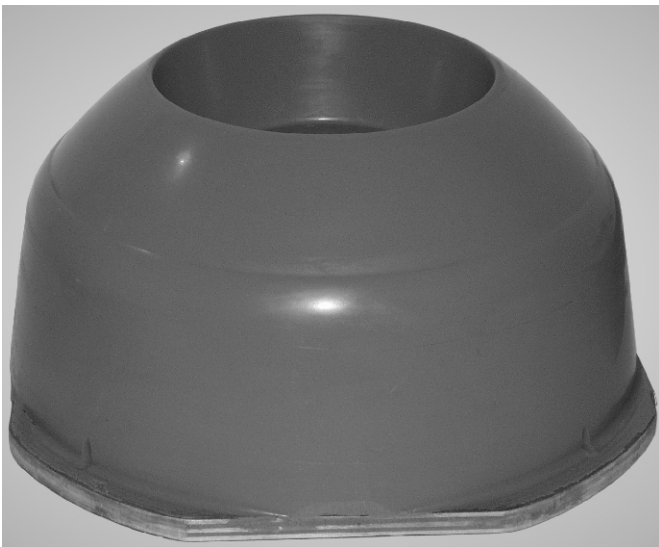

S  $\varnothing$ 241 H 155 Loch  $\varnothing$ 150

Nr. 299

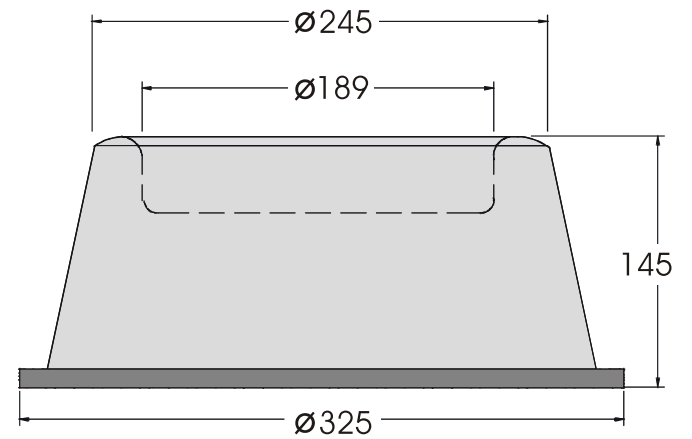

Nr. 298

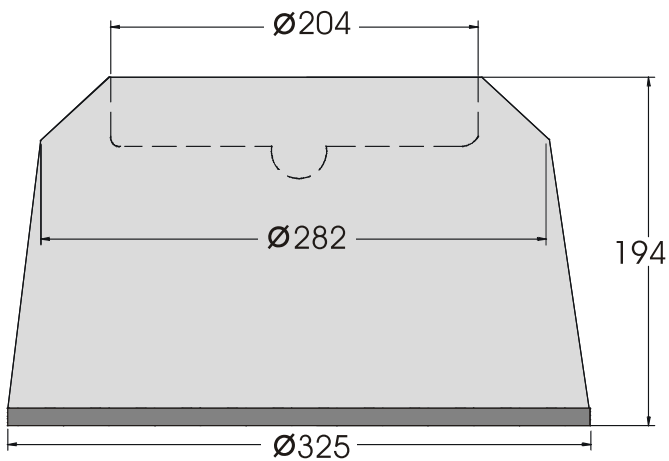

**S**

# LÜCK® TAMPON

H = Höhe  
L = Länge  
S = Silikon  
SL = Silikonlänge  
SB = Silikonbreite

**Nr. 659**

L 87  
SB 17  
H 35

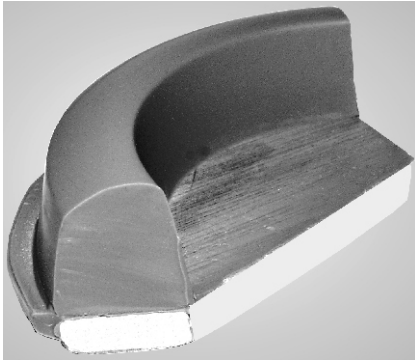

**Nr. 657**

S ø132 SB 14 H 40

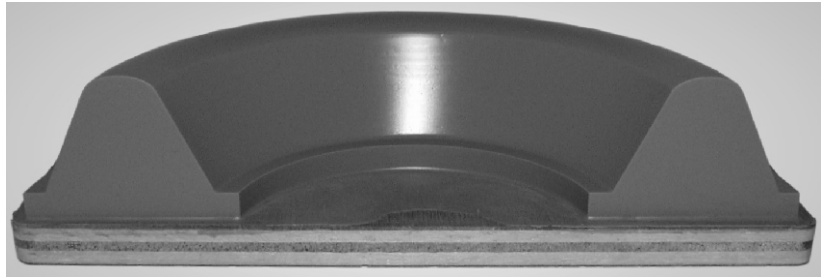

**Nr. 658**

S ø132  
SB 14  
H 35

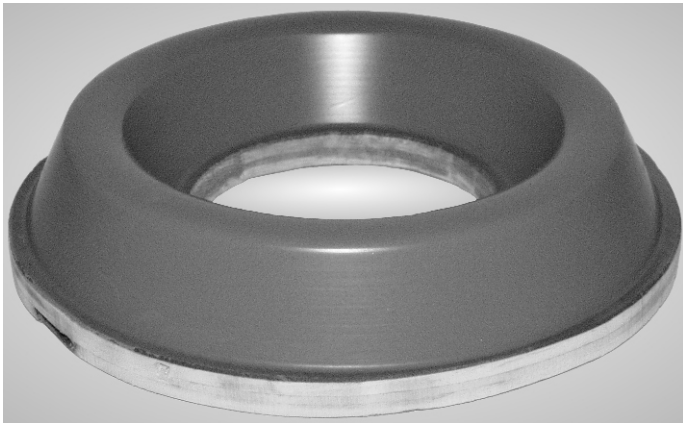

**Nr. 654**

S ø197  
SB 32  
H 61

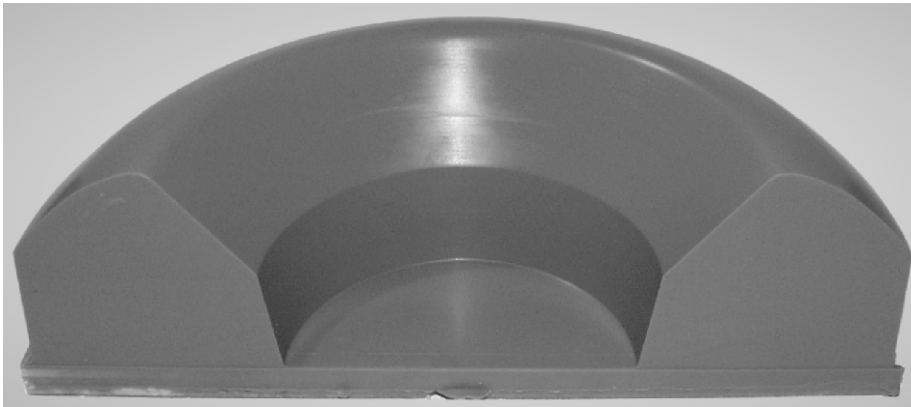

**Nr. 1171**

SL 34  
SB 1  
H 31

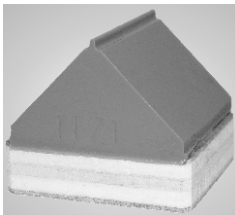

**Nr. 7171/200002**

SL 49  
SB 1  
H 27

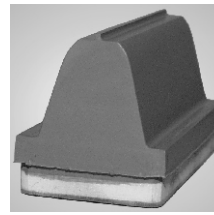

**Nr. 721**

SL 118  
SB 1,5  
H 40

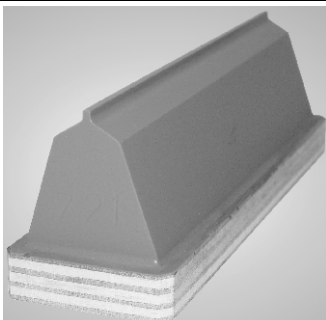

**Nr. 7171/55066**

SL 50  
SB 2  
H 28

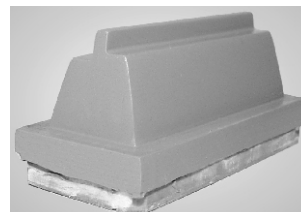

H = height  
 B = width  
 L = length  
 SL = silicone length  
 SB = silicone width

# LÜCK® TAMPON

# S

## Nr. 722

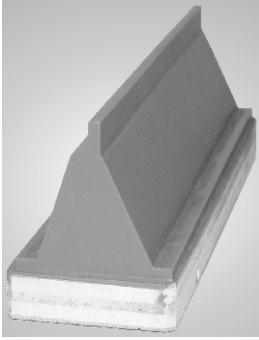

Nr. 715	Silikonfläche	plan	SL 117	SB 1,5
Nr. 716	Silikonfläche	plan	SL 117	SB 1,2
Nr. 718	Silikonfläche	plan	SL 112	SB 2
Nr. 71	Silikonfläche	gewölbt	SL 112	SB 2
Nr. 719S	Silikonfläche	plan	SL 110	SB 2
Nr. 720	Silikonfläche	gewölbt	SL 110	SB 1,8
Nr. 720S	Silikonfläche	plan	SL 111	SB 1,8
Nr. 723	Silikonfläche	gewölbt	SL 110	SB 2
Nr. 728	Silikonfläche	plan	SL 140	SB 1,5
Nr. 729	Silikonfläche	plan	SL 116	SB 2 H 42

SL 112 SB 2 H 40

silicone-surface plane gewölbt=vaulted

## Nr. 727

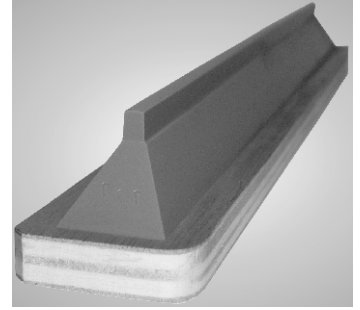

SL 245 SB 3,5 H 31

## Nr. 724

Nr. 724K SL 64

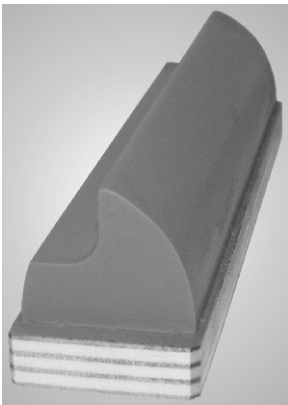

SL 133 H 35

## Nr. 730

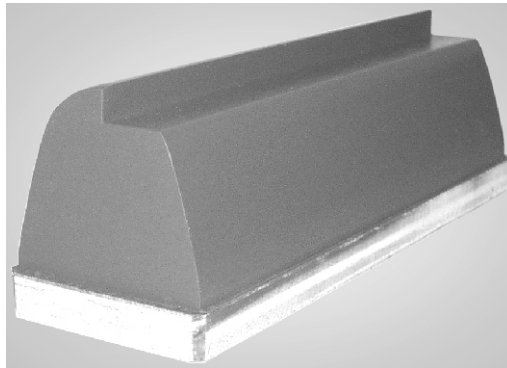

SL 149 SB 13 H 51

## Nr. 207S

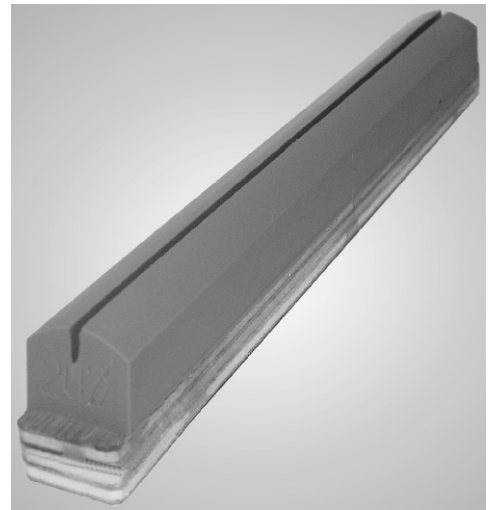

SL 194 SB 19 H 26

## Nr. 573

SL 23  
 SB 4  
 H 35

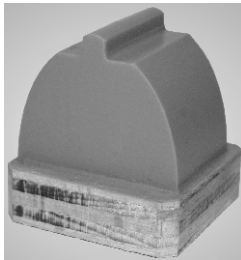

## Nr. 590

SL 35  
 SB 12  
 H 46

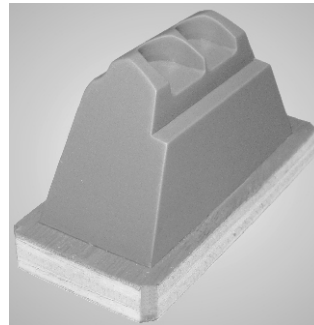

## Nr. 587

SL 68  
 SB 14  
 H 45

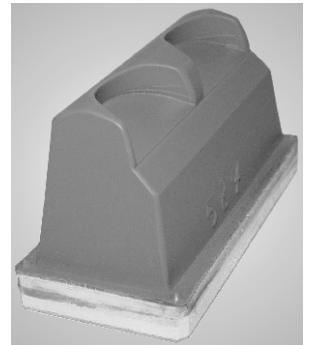

## Nr. 585

Nr. 584 SB 16

SL 79  
 SB 19  
 H 49

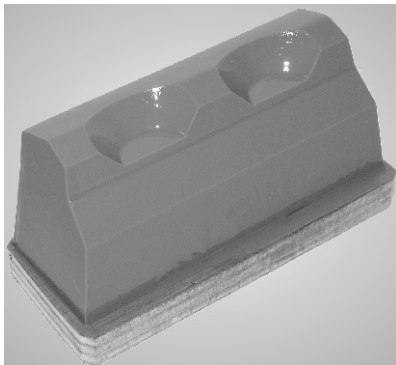

## Nr. 588

SL 95  
 SB 39  
 H 65

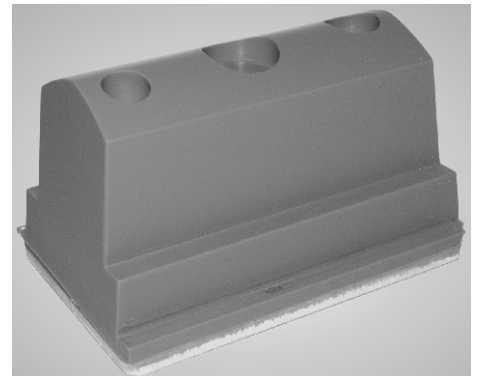

**S**

**LÜCK®  
TAMPON**

H = Höhe  
L = Länge  
SL = Silikonlänge  
SB = Silikonbreite

Nr. 2012 Alu M6

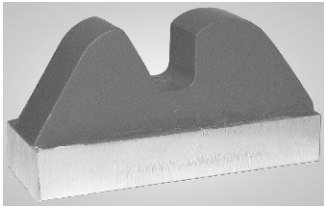

SL 60 SB 11 H 30

Nr. 2051 Alu M6

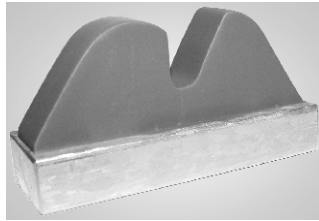

SL 56 SB 12 H 30

Nr. 2021 Alu M6

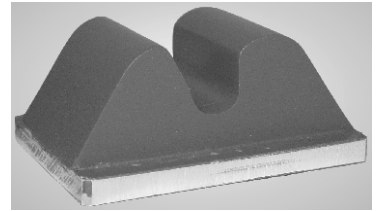

SL 60 SB 28 H 25

Nr. 2001

Nr. 2001 Alu M6 H 31

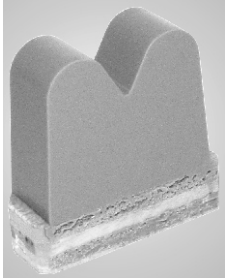

SL 28 SB 12 H 36

Nr. 2016

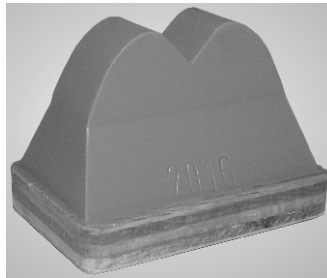

SL 30 SB 15 H 42

Nr. 2025

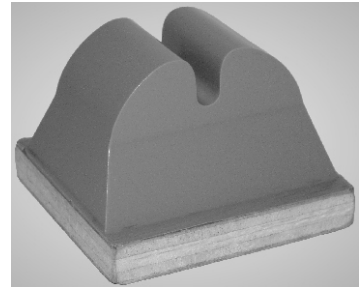

SL 43 SB 28 H 42

Nr. 2053 Alu M6

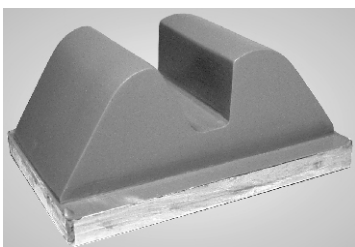

SL 56 SB 29 H 25

Nr. 2021S Alu M6

Nr. 2021 H 30

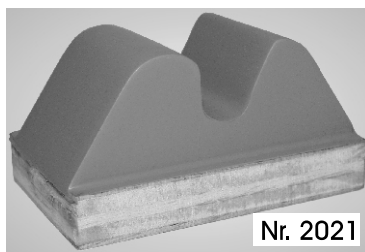

SL 59 SB 30 H 25

Nr. 2020

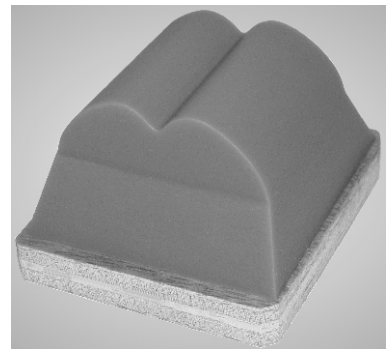

SL 33 SB 39 H 39

Nr. 2052 Alu M6

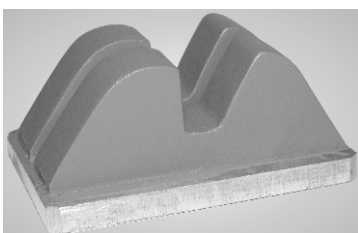

SL 56 SB 28 H 25

Nr. 2026 Alu M6

Nr. 2011 Alu M6 einfach (single)

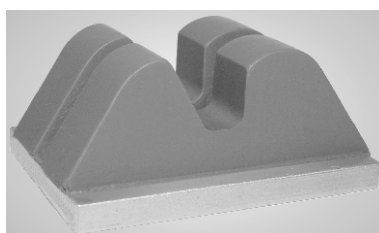

SL 59 SB 30 H 25

Nr. 2030 Alu M6

Nr. 2030 H 30

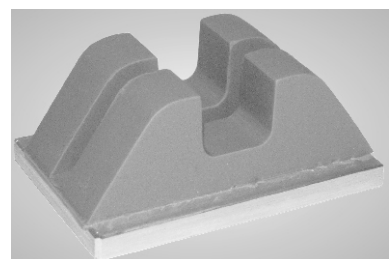

SL 59 SB 30 H 26

H = height  
L = length  
SL = silicone length  
SB = silicone width

# LUCK<sup>®</sup>

## TAMPON

# S

Nr. 2061 Alu M6

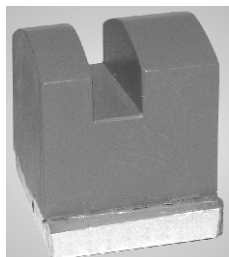

SL 27 SB 25 H 30

Nr. 2062 Alu M6

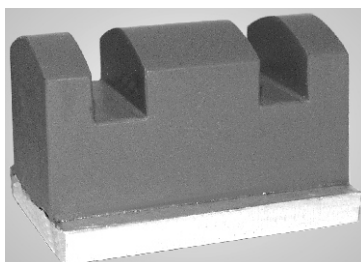

SL 48 SB 25 H 30

Nr. 2063 Alu M6

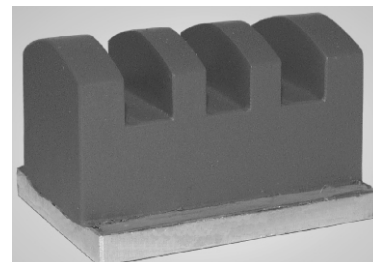

SL 48 SB 25 H 30

Nr. 488

Nr. 488K L 114 SL 112

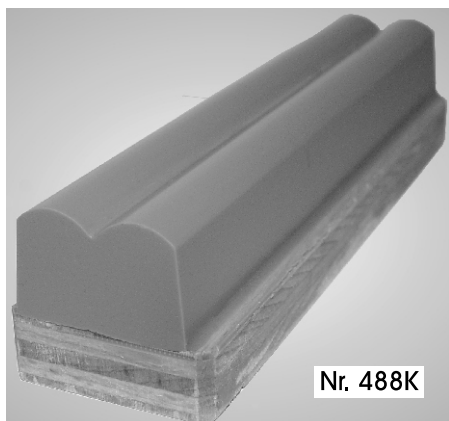

Nr. 488K

SL 242 SB 21 H 25

Nr. 66D

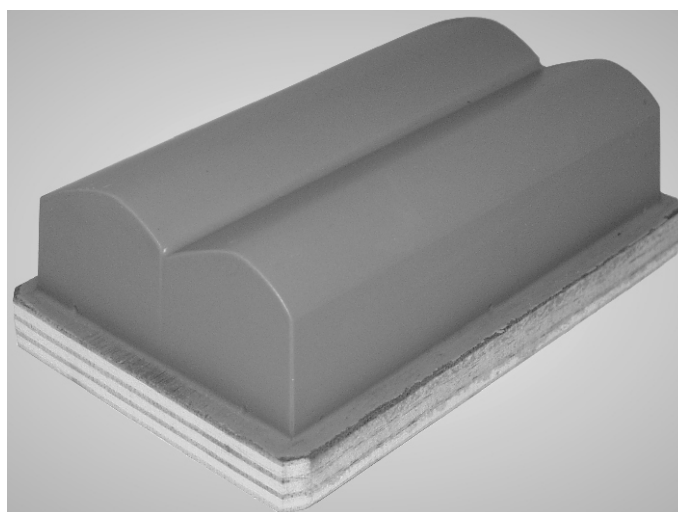

SL 93  
SB 55  
H 35

Nr. 706D

Nr. 701D L 133 SL 97

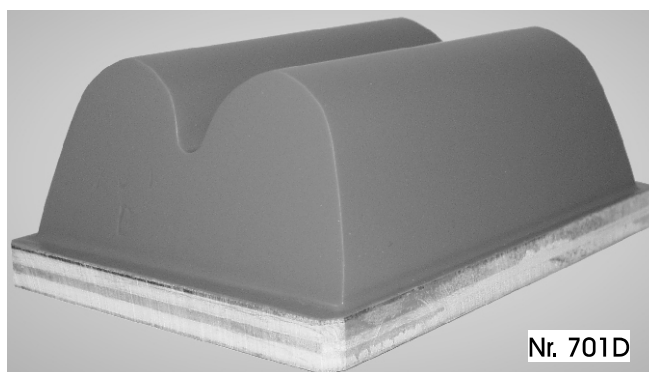

Nr. 701D

SL 350  
SB 61  
H 52

Nr. 702/III

SL 128 SB 98 H 51

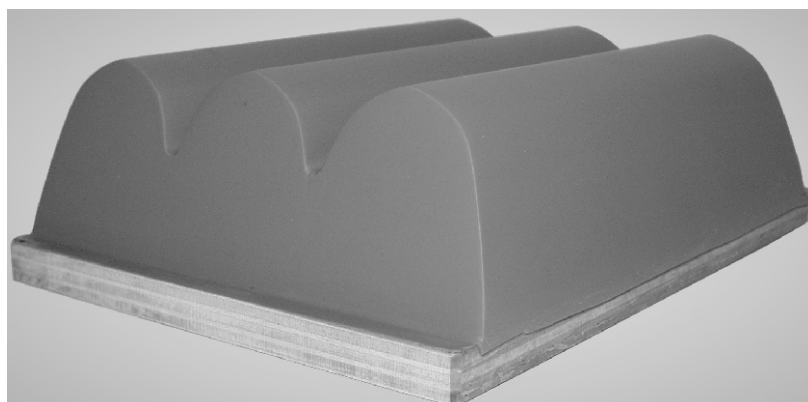

**S**

**LÜCK®**  
**TAMPON**

H = Höhe  
L = Länge  
SL = Silikonlänge  
SB = Silikonbreite

Nr. 583 Alu M6  
Nr. 581 Alu M6 SL 5 SB 1 H 28



SL 4 SB 1,3 H 25

Nr. 582 Alu M6



SL 7 SB 2 H 25

Nr. LP 34

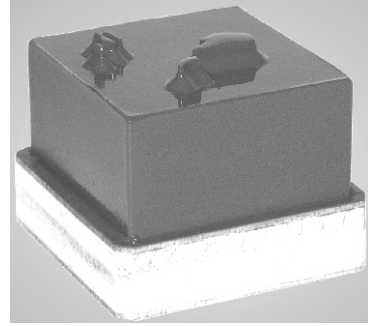

L 37 B 37 H 30

Nr. 92S

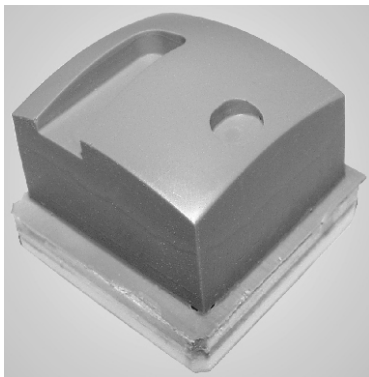

SL 35 SB 35 H 35

Nr. 542

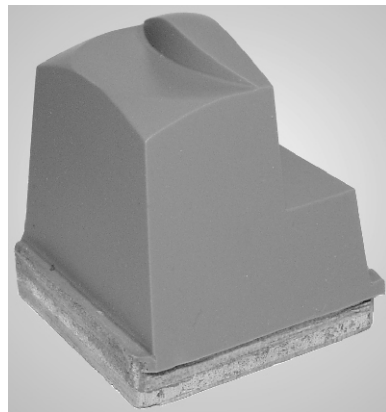

SL 34 SB max. 7 H 52

Nr. 549

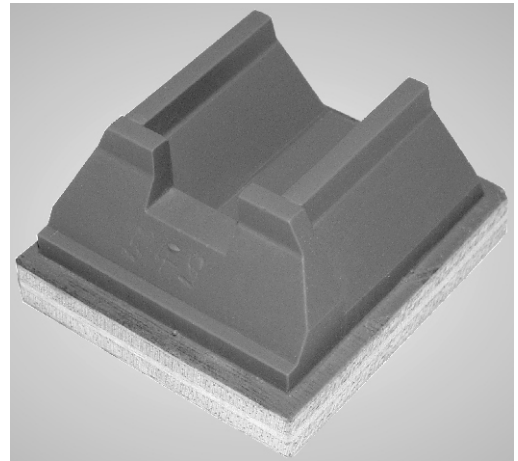

SL 39 SB 36 H 34

Nr. 655

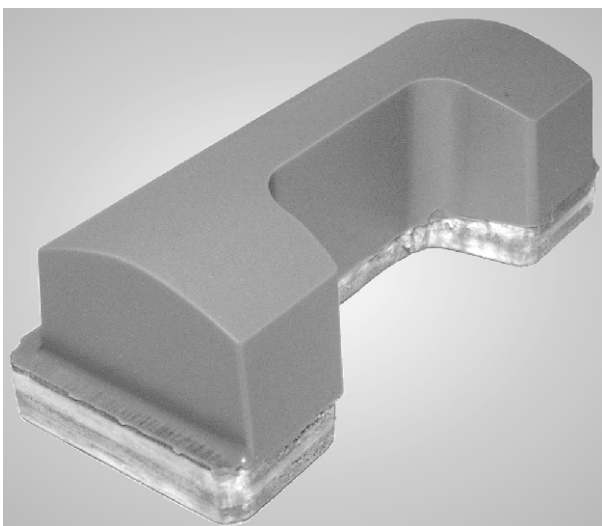

SL 88 SB 34 H 32

Nr. 586

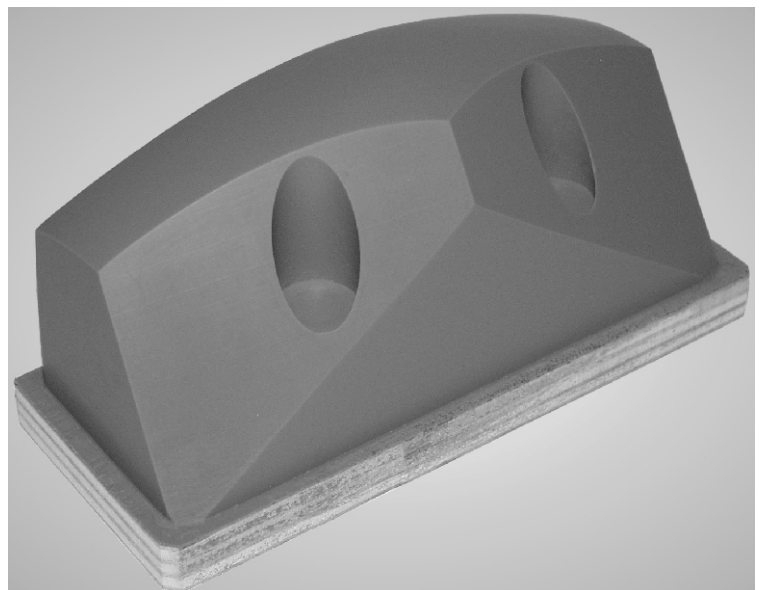

SL 113 SB 34 H 63

H = height  
L = length  
SL = silicone length  
SB = silicone width

# LÜCK® TAMPON

# S

Nr. 83S

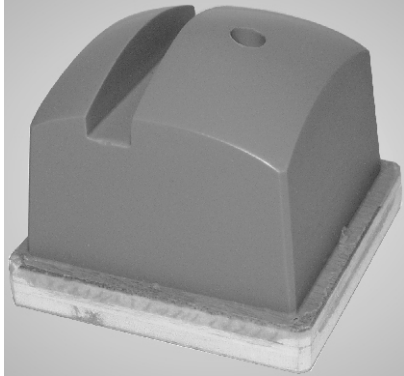

SL 45 SB 45 H 48

Nr. 94S

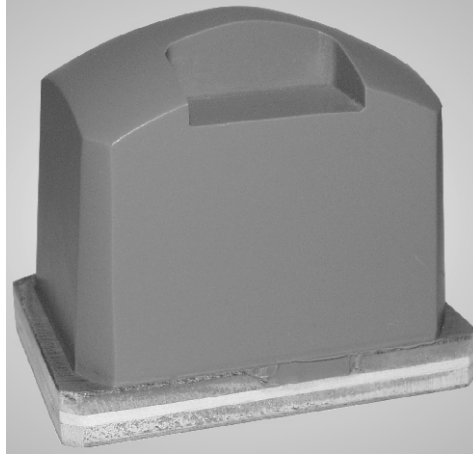

SL 61 SB 43 H 64

Nr. 83SI Alu M6

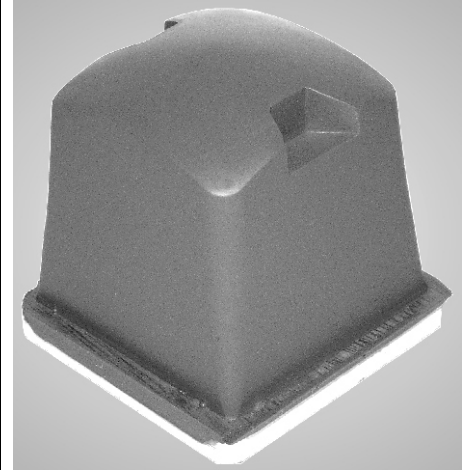

SL 45 SB 45 H 63

Nr. 633

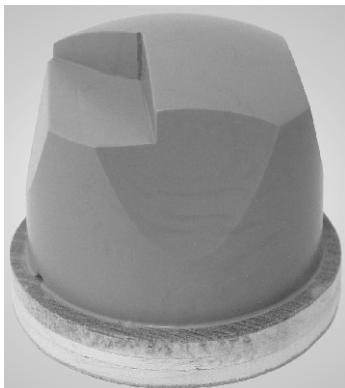

∅ 47 SB 37 H 48

Nr. 732

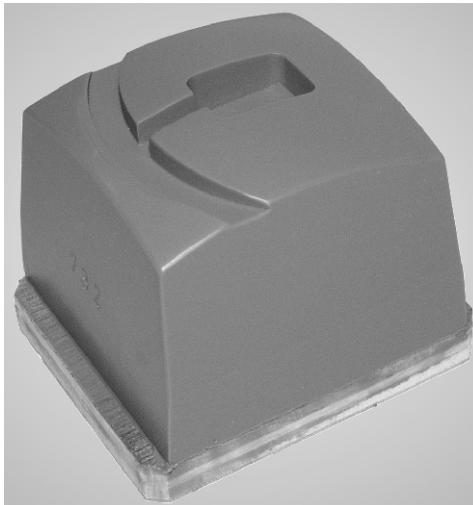

SL 56 SB 52 H 62

Nr. 733

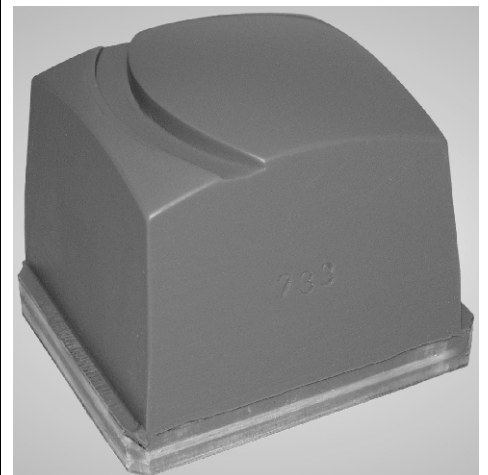

SL 56 SB 52 H 62

Nr. 501

SL 64 SB 37 H 46

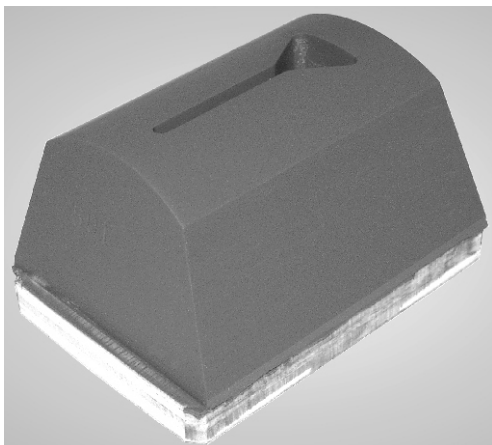

Nr. 17S

SL 85  
H 60

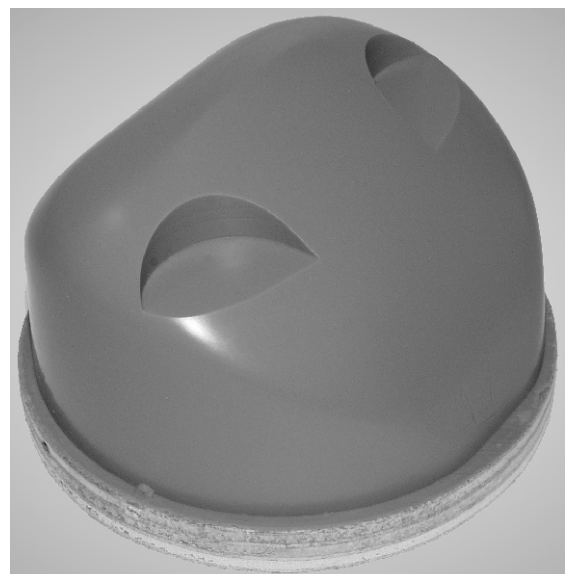



# LÜCK® TAMPON

H = Höhe  
SL = Silikonlänge  
SB = Silikonbreite

Nr. 759 Alu M6

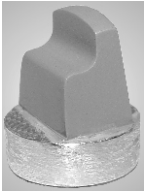

SL 9,5 SB 2,5 H 17

Nr. 371 Alu M6

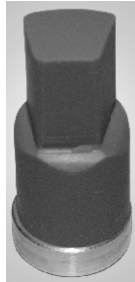

SL 10 H 33

Nr. 574

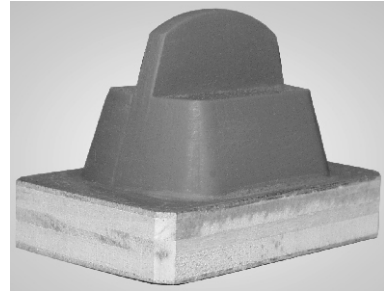

SL 24 SB 3 H 34

Nr. 844

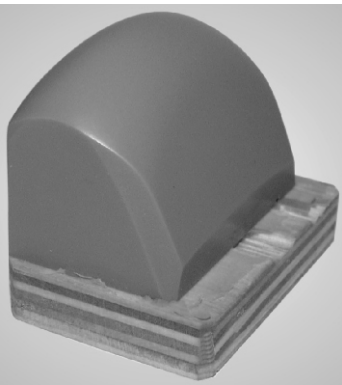

SL 44 SB 15 H 41

Nr. 589

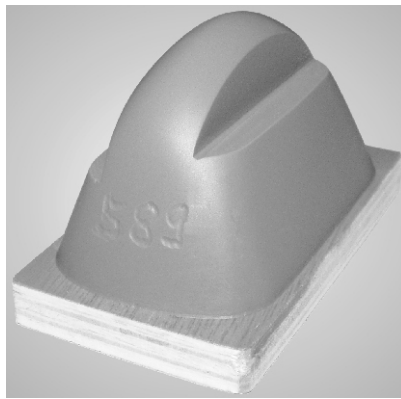

SL 50 SB 17 H 50

Nr. 2040



SL 35 SB 35 H 56

Nr. 679

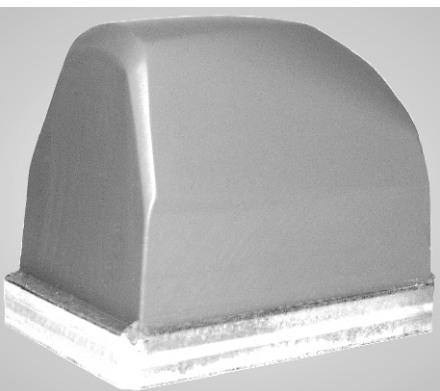

SL 57 SB 25 H 60

Nr. 678

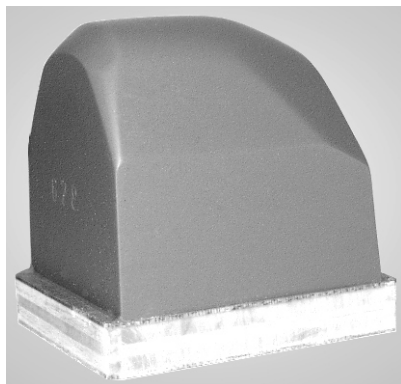

SL 46 SB 42 H 59

Nr. 677

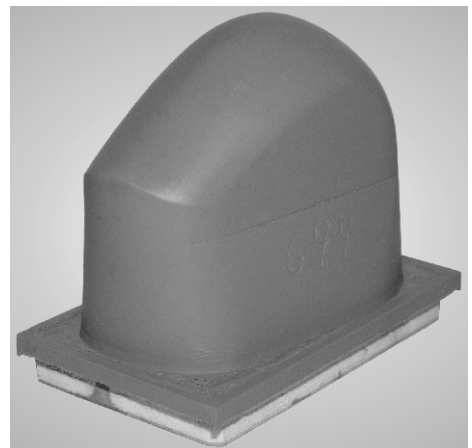

SL 64 SB 28-37 H 66



H = height  
SL = silicone length  
SB = silicone width

# LÜCK® TAMPON

# S

Nr. 539

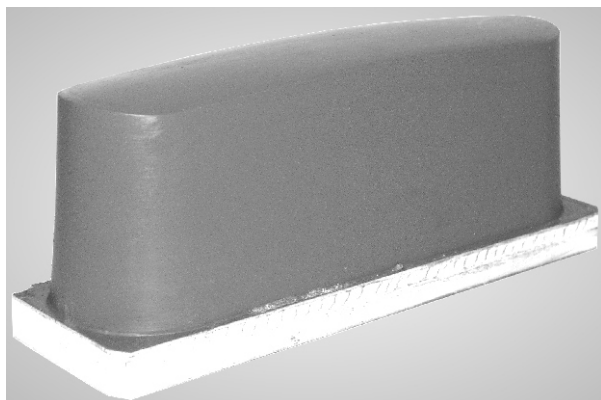

SL 133 SB 34 H 58

Nr. 538

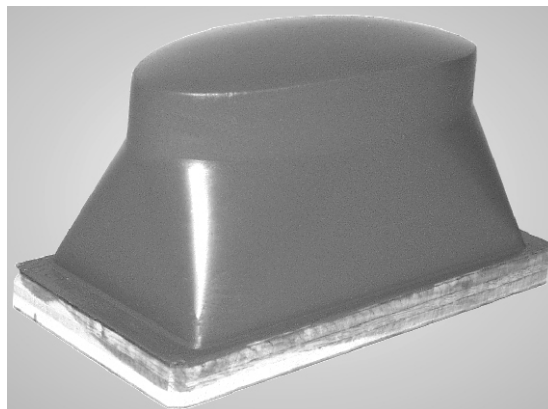

SL 94 SB 43 H 65

Nr. 545

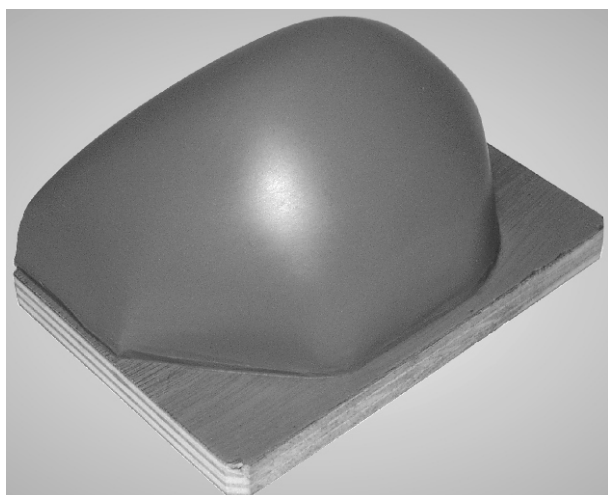

SL 105 SB 73 H 64

Nr. 991



SL 145 SB 48 H 80

Nr. 70S

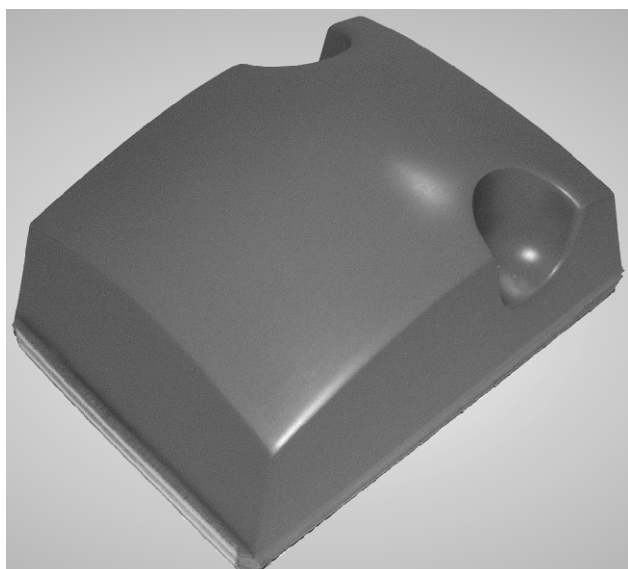

SL 114 SB 95 H 68

Nr. 70SP

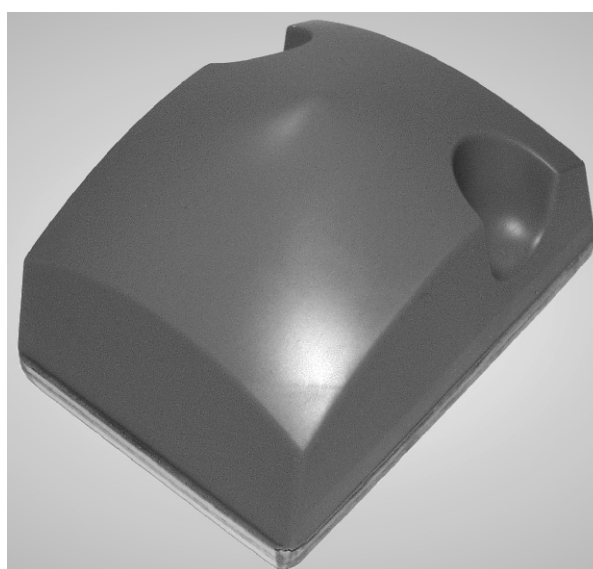

SL 111 SB 93 H 80

**S**

**LÜCK®**  
**TAMPON**

H = Höhe  
SL = Silikonlänge  
SB = Silikonbreite

Nr. 551

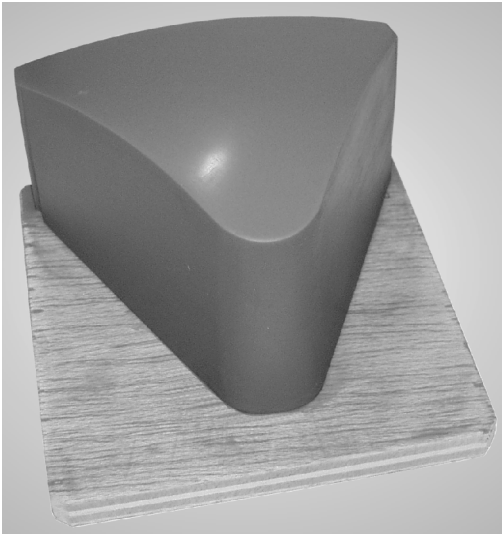

SL 83 SB 90 H 66

Nr. 550S

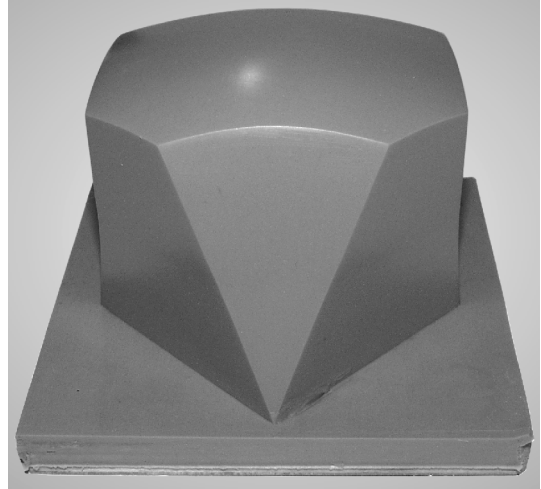

SL 70 SB 79 H 76

Nr. 550



SL 95 SB 95 H 76

Nr. 1500 Alu

Nr. 1501 Alu mit Nut (with groove)

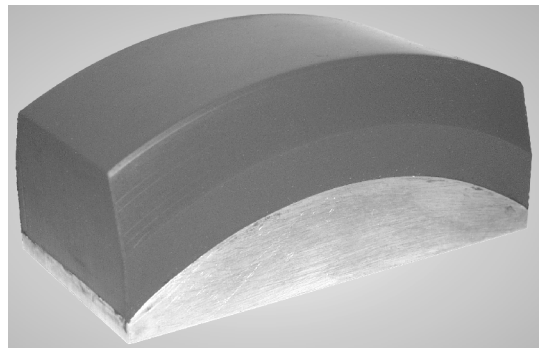

SL 93 SB 42 H 41

Nr. 449

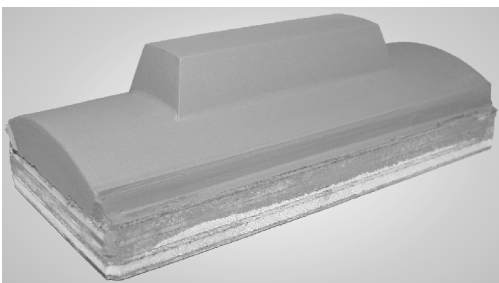

SL 50 SB 13 H 29

Nr. 448

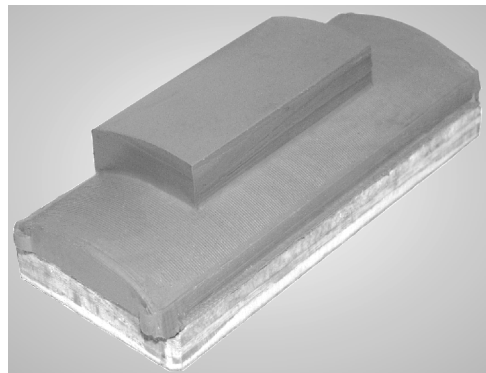

SL 54 SB 27 H 29

## Walzen und Druckwalzen

finden Sie in unserer Preisliste für Walzen. (ca. 150 verschiedene Modelle)

Die Bezeichnungen L,D,K bedeuten Silikonlänge, Gesamtdurchmesser und Durchmesser des Kernes.

Die Walzenkerne werden in der Regel vom Kunden gestellt.

Die Härte des Silikons kann stufenlos bis 70 Shore A gewählt werden. Darüber hinaus auf Anfrage. Der Härte-Standard liegt bei 40 Shore A.

Reinigungswalzen sollten eine superfeuchte Oberfläche aufweisen, um eine bessere Reinigungswirkung zu erzielen. Der Härte-Standard liegt bei 5 Shore A.

Für Etikettendrucker bieten wir ein spezielles Antihaft-Material an.

Gebrauchte Alu-Kerne von Druckwalzen können problemlos aufgearbeitet und wiederverwendet werden.

Vorhandene Walzenformen können kostengünstig auf Ihren Walzenkern angepasst werden.

## Rollers and Printing Rollers

Please find the about 150 different types of rollers and printing rollers in our roller price list.

The designations L, D, K stand for silicone length, complete diameter and diameter of the core.

Usually the customer indicates the roller's core.

Hardness of the silicone can be chosen infinitely up to 70 shore A. Hardness's exceeding this value can be delivered on request. Hardness standard lies at 40 shore A.

Stripper rollers should have a very humid surface to achieve a better cleaning effect. Hardness standard lies at 5 shore A.

We offer a special anti-sticking product for label printers.

Used printing roller alu-cores can without problems be regenerated and used again.

Existing roller forms can at low cost be adjusted to you roller core.

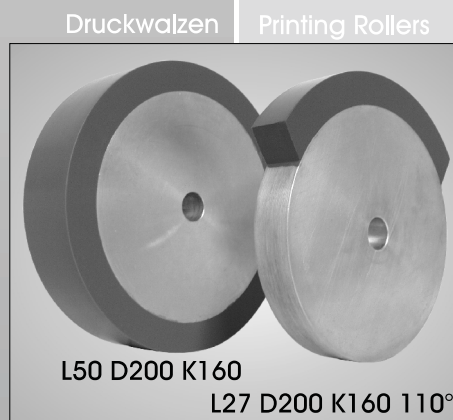

## Zubehör

### Stahlklischees

In unserer Preisliste bieten wir Stahlklischees in den Abmessungen von 30x70 mm bis 200x300 mm in 10 mm Stärke an. (Sondergrößen auf Anfrage)

Das Stahlklischee besteht aus einem hochwertigen gehärteten Spezialstahl dessen Härtegrad bei ca. 63 HRC liegt. Die Rauhtiefe beträgt ca. 1  $\mu\text{m}$ .

Vorteile:

beste Druckqualität, äußerst Verschleißarm (min. 1 Million Raketungen - bei sachgerechtem Umgang)

Nachteile:

höherer Preis

Für die Ätzung benötigen wir einen reprofähigen Film (Schichtseite unten) bzw. Daten zur Erstellung eines Filmes. Ferner benötigen wir die gewünschte Ätztiefe (Empfehlung: Bei geschlossenen Drucksystemen ca. 19  $\mu\text{m}$ , bei offenen Drucksystemen ca. 23  $\mu\text{m}$ )

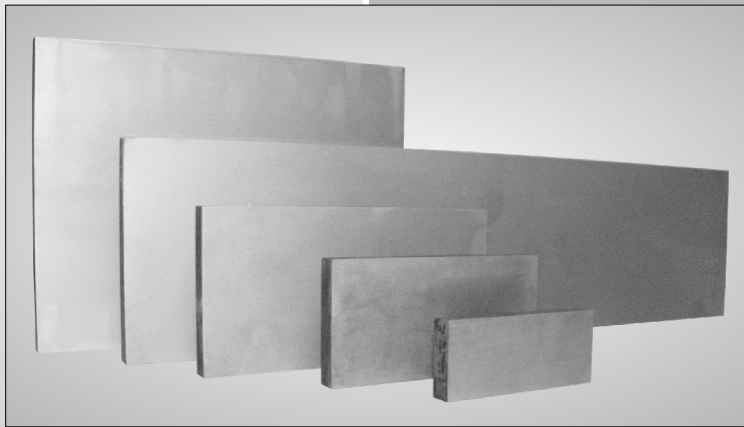

### Blechklichees

Unser Angebot an Blechklichees reicht von den Grössen 50x50mm bis 200x600mm (Preisliste)

Das Material besteht aus 0,5mm starkem Federbandstahl, dessen Härte bei ca. 52-54 HRC liegt.

Vorteile: geringerer Preis als Stahlklischees

Nachteile: höherer Verschleiß

Ätzung: siehe Stahlklischees

### Kunststoffklischees

Die Grössenauswahl der Kunststoffklischees Typ ST 52 reicht von 30x70mm bis 250x250mm (Preisliste).

Sie besitzen eine Gesamtstärke von 0,52mm. Die Kunststoffklischees sind unbelichtet und alkoholauswaschbar. Die Ätztiefe ist abhängig von Belichtungszeit und Rasterweite. Eine Verpackungseinheit beinhaltet 10 Kunststoffklischees.

Vorteile:

schnelle Einsatzbereitschaft, geringster Preis

Nachteil:

hoher Verschleiß

Kunststoffklischees eignen sich hauptsächlich für kleinere Auflagen, Andrucke, Vorserien und eilige Aufträge.

## ACCESSORIES

### Steel printing clichés

In our price list we offer steel printing clichés with dimensions from 30 x 70 mm up to 200 x 300 mm with a thickness of 10 mm (special sizes on your request).

The steel printing clichés consists of high quality hardened special steel with a hardness degree of approx. 63 HRC. The peak-to-valley height is ca. 1  $\mu\text{m}$ .

Advantages:

Highest printing quality, extremely resistant to wear (ca. 1 million applications at appropriate use).

Disadvantages:

Higher price

For engraving we need a reproducible film (sensitised face down) or data for the production of a film. Further we need the required depth of engraving (recommendation: for closed printing systems ca. 19  $\mu\text{m}$ , for open printing systems ca. 23  $\mu\text{m}$ )

### Sheet metal printing clichés

Our range of sheet metal printing clichés reaches from the size of 50 x 50 mm to 200 x 600 mm (price list). The material consists of 0,5 mm thick spring band steel with a hardness of ca. 52-54 HRC.

Advantages: Less expensive than steel printing clichés

Disadvantages: Higher rate of wear

Engraving: see steel printing clichés

### Plastic printing clichés

The range of sizes of our plastic printing clichés type ST 52 reaches from 30 x 70 mm to 250 x 250 mm (price list).

They have a thickness of 0,52 mm. The plastic printing blocks are raw and washable with alcohol. The depth of the engraving depends on the exposure time and screen width. One packing unit contains of 10 plastic printing clichés.

Advantages:

Fast application possible

Disadvantage:

Higher rate of wear

Plastic printing block are mainly suitable for small editions, proof printing, pilot runs and urgent orders.

## Rakelmesser

Rakelmesser für Stahlklischees bestehen aus gehärtetem Federbandstahl und sind beidseitig geschliffen. Unser Angebot umfasst eine Materialstärke von 0,5 mm bei einer Höhe von 19mm. Die Längen der Rakelmesser variieren von 40mm bis 530mm (Preisliste). Andere Maße liefern wir auf Anfrage.

Rakel für Kunststoffklischees (Tiefdruckrakel) bestehen aus gehärtetem Federbandstahl und sind einseitig geschliffen. Unser Angebot umfasst eine Materialstärke von 0,2mm bei einer Länge von 1000mm. Die Höhen der Tiefdruckrakel variieren von 20mm bis 30mm (Preisliste). Andere Maße liefern wir auf Anfrage.

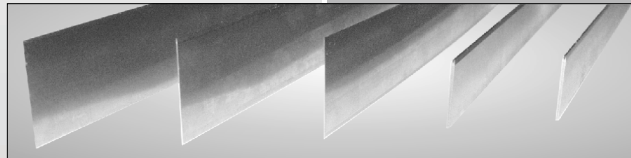

## Doctor blades

Doctor blades for steel printing clichés consist of a hardened spring band steel and are grind on both sides. We offer material thicknesses from 0,5 mm at a height of 19 mm. The lengths of the doctor blades vary from 40 mm to 530 mm (price list). Other measures are available on request.

Doctor blades for plastic printing clichés (gravure printing) consist of hardened spring band steel and are grind on one side. We offer a material thickness of 0,2 mm at a length of 1000 mm. The gravure printing heights vary from 20 mm to 30 mm (price list). Other measures are available on request.

## Sonstiges

Tamponpflegespray, 200ml  
(unterstützt die Rückbildung von Verformungen des Tampons, schützt die Oberfläche des Drucktampons, z.B. Einlagern)

Tamponpflegeöl, 1l  
(wird per Hand auf den Drucktampon aufgetragen - unterstützt die Rückbildung von Verformungen des Tampons, schützt die Oberfläche des Drucktampons z.B.)

Silikonkleber, 90ml Tube

Auswaschmittel für alkoholauswaschbare Kunststoffklischees, 5l Gebinde

Erstellen Sie selbstständig Ihre Filme mit Hilfe von Laserfolien für Laserdrucker (100 Blatt) und Tonerverdichter für Laserdrucker (400ml).

## Other accessories

Printing pad maintenance spray, 200 ml  
(supports regeneration of pad deformations, protects the pad surface, e.g. for storage)

Printing pad maintenance oil, 1l  
(is applied manually onto the printing pad – supports regeneration of pad deformations, protects the pad surface).

Silicone glue, 90 l tube

Solvent for plastic printing clichés to be washed out with alcohol, 5 l drum



Produce your films yourself with laser foils for laser printers (100 sheet) and toner condenser for laser printer (400 ml).

# INDEX

NR.	SEITE	NR.	SEITE	NR.	SEITE	NR.	SEITE	NR.	SEITE
1M	68	44S22	70	77	60	130	12	233	58
9AluM5	23	45S13	70	78	11	131	11	240	42
10AluM3	22	45S16	70	79	14	135	12	250	66
11AluM5	22	46L23	70	80	40	137	58	250/65	66
12	7	48	54	81	34	141	39	250/130/65	66
12AluM6	7	48AluM6	54	82	35	142	41	250/130/105	66
12S	7	48/46AluM6	54	82S	35	143	40	250/190/65	66
12SAluM6	7	49	27	82SAluM6	35	143K	40	250/190/105	66
13	8	50	11	83	31	144	38	250/250/65	66
13K	8	51	49	83S	79	144K	38	250/250/105	66
13SK	9	52	9	83SAluM6	79	145	44	250/280/105	66
14	17	53	39	83K	31	146	40	250/380/105	66
15	17	53K	39	84	38	147	38	251/305	65
15K	17	54	40	85	27	147K	38	251/390	65
16	17	55	36	86	33	150	14	256	64
17	17	56	9	87	67	152	14	256K	64
17S	79	56AluM6	9	88	35	153	16	257	64
18	55	57	10	89	29	154	14	260	46
19	24	58AluM5	52	89D	68	155	14	260K	46
19AluM6	24	59	37	90	28	156	13	264	60
19DAluM6	67	60	35	90K	28	157	72	265	47
20	47	61	37	91	27	158	13	276	67
20S	47	62	62	91K	27	160	14	277	35
21	48	62/50	62	92	28	165	14	278	36
21S	48	62/110	62	92AluM6	28	170	15	279	35
22	27	63	63	92S	78	179	44	280	42
23	28	63/65	63	93	28	180	43	280K	42
24	26	63/115	63	93K	28	180K	43	281	41
25	8	63/130	63	94	30	190	15	281K	41
26	9	63/220	63	94K	30	191	21	282	39
27	31	64	60	94S	79	192	21	282K	39
27K	31	64/20AluM6	60	95	29	193	17	283	42
28	9	64/40AluM6	60	96AluM6	8	195	24	283K	42
28D	67	64/55AluM6	60	96SAluM6	8	195AluM6	24	284	43
29	36	64/75	60	97	7	196	25	284K	43
30	32	64/75AluM6	60	97AluM6	7	197AluM5	6	298	73
31AluM6	7	65	61	98	52	198AluM6	7	299	73
32AluM6	7	65/120	61	98AluM6	52	200	49	300	15
33	26	65K	61	98/85	52	205	54	301	54
33AluM6	26	65K/120	61	98/85AluM5	52	206	56	302	16
34	24	66	60	99Alu	50	206/40	56	303	73
34AluM6	24	66/25	60	100	51	206/40Alu 2xM6	56	304	73
35	8	66/55	60	106	10	206/100	56	305	46
35AluM6	8	66D	77	107	8	207	56	307	23
35S	8	67	31	108	12	207S	75	308	24
35SAluM6	8	68	51	109	11	207/100	56	308AluM6	24
35TG	8	68Alu	51	110	11	210	43	309	23
36	9	69	51	111	9	220	45	309AluM6	23
37	10	69AluM5	51	112	10	221	45	310	47
38AluM5	52	70S	81	112AluM6	10	222	45	320	57
39	11	70SP	81	113	12	223	44	320/26	57
39AluM6	11	71	25	113K	12	224/105	46	320/45	57
40	10	71K	25	114	13	224/115	46	326AluM5	53
41	12	72	24	124	14	228	59	327AluM5	54
42	12	74	56	125	13	229	59	328	55
43	17	75	60	126	11	229Alu2xM6	59	328/60	55
44S17	70	76	60	127	11	230	59	328/60AluM5	55

# INDEX

NR.	SEITE	NR.	SEITE	NR.	SEITE	NR.	SEITE	NR.	SEITE
329	55	427	29	550	82	658	74	738	57
340	33	430	28	550S	82	659	74	740	62
341	33	430D	68	551	82	660	60	740/450	62
341K	33	435	8	560	29	663	12	745AluM5	6
342	41	435AluM6	8	561	29	667	69	758	25
342K	41	445	48	563	48	668	69	758AluM6	25
343	41	446	48	565	30	669	70	759AluM6	80
344	32	447	48	566	30	670	69	763	63
345	32	448	82	573	75	671	69	765	30
346	37	449	82	574	80	672	69	765K	30
352	55	463	12	579AluM5	7	673	69	766	31
353	61	464	10	580AluM6	7	674	69	767	8
354	65	465H Alu 2xM6	10	581AluM6	78	675	69	767AluM6	8
354K	65	466LH Alu2xM6	69	582AluM6	78	676	70	768	25
355	64	467LH Alu2xM6	69	583AluM6	78	677	80	769	21
359	63	468LH Alu2xM6	69	584	75	678	80	769K	21
360	65	488	77	585	75	679	80	770	21
360/80	65	488K	77	586	78	680	50	771	29
360K	65	494	23	587	75	700	59	772	17
361AluM6	6	498/72	52	588	75	701	59	773	17
362AluM6	6	500	66	589	80	701D	77	774	17
363AluM4	6	501	79	592	47	702	59	775	18
364AluM6	6	504	34	592AluM6	47	702/III	77	776	18
364SAluM6	6	507	72	593	68	703	59	776K	18
365AluM6	6	509	26	593S	68	704	59	777	18
366AluM4	6	512	73	594	67	705	59	778	18
367Alu	6	513	71	595	67	706	59	778K	18
368Alu	6	517	17	596	67	706D	77	779	19
369AluM6	6	518	23	610	58	707	57	779K	19
371AluM5	80	519	23	619	23	708	55	780	19
373AluM6	22	519AluM6	23	619AluM6	23	709	7	780K	19
374AluM6	22	520	69	620	35	709AluM6	7	781	19
375AluM6	6	521	25	623	39	710	33	781WS	19
380	52	522AluM6	47	623K	39	711	10	782	19
384	35	524	47	624	26	711AluM6	10	783	20
386	28	525	47	624AluM6	26	712	56	783K	20
391	24	528	49	629	53	713	60	784	20
391AluM6	24	532	28	629AluM5	53	713/100	60	784K	20
392	24	533	27	633	79	715	75	785	33
393	23	533AluM6	27	636	10	716	75	786	20
393AluM6	23	534	29	636K	10	717	53	786K	20
393/25AluM6	23	534AluM6	29	639	70	718	75	796	34
393/30AluM6	23	535	8	639S	70	719	75	797	34
394	23	535AluM6	8	640	68	719S	75	798	34
395	25	536	9	641	68	720	75	799	49
396	26	537AluM6	8	643	71	720S	75	800	72
402	32	538	81	643S	71	721	74	801	68
404	48	539	81	644	70	722	75	802	72
404K	48	541	24	645	35	723	75	803	72
406	48	541AluM6	24	646	69	724	75	804	71
407	38	542	78	647	8	724K	75	805	71
418	56	544	70	648	69	727	75	807	72
422	27	545	81	651	31	728	75	808	71
423	26	546S	70	652	31	729	75	809	70
424	25	547	69	654	74	730	75	810	71
425	47	548	69	655	78	732	79	811	71
425AluM6	47	549	78	657	74	733	79	814	70

# INDEX

NR.	SEITE	NR.	SEITE	NR.	SEITE	NR.	SEITE
818	72	1913	54	3806	52	7135	60
820	25	1914	54	5197AluM5	6	7136	60
820AluM6	25	1915	54	6161	57	7137	60
822	73	1916	54	6162	57	7171	53
823	73	2001	76	6163	57	7171/55066	74
831	54	2001AluM6	76	6164	57	7171/200002	74
843	70	2002AluM5	22	6165	57	7172	53
844	80	2003AluM6	22	6166	57	7173	53
846	70	2006AluM5	22	6167	57	7174	53
846S	70	2006MAluM6	22	6168	57	7175	53
852	27	2008AluM5	22	6301	63	7176	53
853	26	2008MAluM6	22	6302	63	7197AluM5	6
854	26	2011AluM6	76	6303	63	7268	50
855	26	2012AluM6	76	6304	63	7270	50
884	40	2013AluM6	22	6305	63	7271	50
891	48	2014AluM6	22	6306	63	7370	63
902	72	2015AluM5	22	6307	63	7371	63
903Alu3xM6	72	2016	76	6308	63	7372	63
914	20	2018Alu	50	6309	63	7401	62
971	37	2020	76	6801	50	7402	62
971K	37	2021AluM6	76	6802	50	7403	62
972	34	2021SAluM6	76	6803	50	7404	62
980	52	2022AluM5	23	6804	50	7405	62
991	81	2023AluM6	67	6805	50	7406	62
1004	36	2024AluM5	23	6806	50	7407	62
1005	47	2025	76	7001	59	LP34	78
1006	24	2026AluM6	76	7002	59		
1006K	24	2027AluM4	22	7003	59		
1071	27	2028Alu	67	7004	59		
1101	51	2029	67	7005	59		
1102	51	2030	76	7006	59		
1103	51	2030AluM6	76	7007	59		
1104	51	2034AluM6	22	7071	57		
1105	51	2039	24	7072	57		
1106	51	2039AluM6	24	7073	57		
1120S	53	2040	80	7074	57		
1121	58	2051AluM6	76	7075	57		
1122	58	2052AluM6	76	7076	57		
1123	58	2053AluM6	76	7077	57		
1124	58	2061AluM6	77	7081	55		
1125	58	2062AluM6	77	7082	55		
1126	58	2063AluM6	77	7083	55		
1131	62	2195AluM6	6	7084	55		
1132	62	2197AluM5	6	7085	55		
1133	62	3011	54	7086	55		
1134	62	3012	54	7121	56		
1135	62	3013	54	7122	56		
1136	62	3014	54	7123	56		
1171	74	3015	54	7124	56		
1202	42	3016	54	7125	56		
1229	61	3197AluM5	6	7126	56		
1294AluM6	7	3281	55	7127	56		
1500Alu	82	3801	52	7128	56		
1501Alu	82	3802	52	7131	60		
1610	18	3803	52	7132	60		
1911	54	3804	52	7133	60		
1912	54	3805	52	7134	60		



# Drucktampon-Bestellformular

Telefax: (49) 02359 290442

Tampo-Technik GmbH  
Postfach 1443

D-58557 Kierspe

-

Besteller/Rechnungsanschrift

Firma \_\_\_\_\_

Abteilung \_\_\_\_\_

Name \_\_\_\_\_

Straße \_\_\_\_\_

Postfach \_\_\_\_\_

PLZ/Ort \_\_\_\_\_

Bestellnummer \_\_\_\_\_

Datum \_\_\_\_\_

Lieferanschrift (falls abweichend von oben)

Firma \_\_\_\_\_

z.Hd. \_\_\_\_\_

Straße \_\_\_\_\_

PLZ/Ort \_\_\_\_\_

Anzahl	Tampon Nr.	Farbe	Härte	Gewinde	Oberfläche

**Farbe:** rote Qualität (Standard – höchste Druckqualität, höchste mechanische Dauerbeanspruchung, langfristige Konstanz der Shore-Härte), weiße Qualität (bessere Erkennung des Druckbildes auf dem Stempel), schwarze und blaue Qualität (geringeres statisches Aufladungspotential), gelbe Qualität (bessere manuelle Nachbereitung des Tampons z.B. Beschneiden)

**Härte:** Sie können stufenlos von 25 Shore 00 bis ca. 25 Shore A bei uns bestellen. (z.B. 1 Shore A = weich, 6 Shore A = mittel, 12 Shore A = hart)

**Gewinde:** auf Wunsch liefern wir die Schichtholz Tampon-Träger mit M6 Gewindeeinsätzen, je nach Größe des Tampon-Trägers sind auch mehrere Gewindeeinsätze sinnvoll.

**Oberfläche:** neben der häufig bevorzugten normalen Oberflächenbeschaffenheit, bieten wir auch supertrocken, trocken (z.B. für Metalldruck), als auch feucht und superfeucht (für dickeren Farbauftrag-Vorsicht Anlaufschwierigkeiten) an.

Beispiel:

Anzahl	Tampon Nr.	Farbe	Härte	Gewinde	Oberfläche
5	Nr. 13K	rot	6 Shore A	1 x M6	trocken
8	Nr. 535 Alu M6	rot	8 Shore A		

Datum und Unterschrift: \_\_\_\_\_

# Printing pads order form

fax: +49 2359 290442

Tampo-Technik GmbH  
Postfach 1443

D-58557 Kierspe

-

Orderer/ invoice address

Company \_\_\_\_\_

Department \_\_\_\_\_

Name \_\_\_\_\_

Street \_\_\_\_\_

PO Box \_\_\_\_\_

Post code/town \_\_\_\_\_

Order number \_\_\_\_\_

Date \_\_\_\_\_

Delivery address (if different from above)

Company \_\_\_\_\_

Att. \_\_\_\_\_

Street \_\_\_\_\_

Post \_\_\_\_\_

code/town \_\_\_\_\_

Quantity	Printing pad number	Color	Hardness	Thread	Surface

**Color:** Red quality (standard-highest printing quality, highest mechanic continuous stress, long-term constancy of shore hardness), white quality (better recognition of the printing format on the pad), black and blue quality (lower static charging potential), yellow quality (suitable for manual finishing of the printing pad, e.g. trimming)

**Hardness:** You can order an infinitely variable hardness from 25 shore 00 up to ca. 25 shore A (e.g. 1 shore A = soft, 6 shore A = middle, 12 shore A = hard)

**Thread:** If desired we supply the printing support out of laminated wood with M6 thread-inserts, according to size of the pad support also several thread-inserts can be useful

**Surface:** In addition to the often preferred normal surface structure we offer both super dry, dry (e.g. metal-printing) and humid, super humid surfaces (for thicker colour application – Warning : starting difficulties).

Example:

Quantity	Printing pad number	Color	Hardness	Thread	Surface
5	No. 13K	red	6 Shore A	1 x M6	dry
8	No. 535 Alu M6	red	8 Shore A		

Date and signature: \_\_\_\_\_

## Beispiele für die Anwendung von Lück-Tampons® References for the use of Lück-Tampons®

### Peugeot-Löwe

Die Firma Linden GmbH & Co. KG verwendet den Lück-Tampon Nr. 34 zum Bedrucken des Peugeot Emblems. Die Tampon-Form ist den Vertiefungen des Druckgutes exakt angepasst.

### Peugeot-Lion

The company Linden GmbH & Co. KG uses the Lück printing pad number LP34 for printing the Peugeot logo. The pad is adjusted precisely to the cavities of the material to be printed.



### Popsy-Flaschenverschluss

Dieser Flaschenverschluss der Firma Krugmann Markenspirituosen wird im Tampondruck dekoriert. Gerade durch die unsymmetrisch gewölbte Oberfläche bleibt dieses Druckverfahren als technische Lösung der Favorit. Eingesetzt wird der Drucktampon Nr. 509 in 3 Shore A.

### Popsy-Bottle cap

This bottle cap of company Krugmann Markenspirituosen is decorated by means of pad printing. This kind of printing is the most advanced technical solution, in particular due to the non symmetric surface. We use printing pad no. 509 with 3 shore A.



### MAPA Beruhigungssauger

NUK Beruhigungssauger der Firma MAPA GmbH werden mit dem Lück-Tampon Nr. 468 in 12 Shore A bedruckt. Die Aussparung wurde dem Schaft des Druckgutes angepasst. MAPA – calming dummies

### MAPA – calming dummies

NUK calming dummies of company MAPA GmbH are printed with the Lück printing pad number 468 in 12 shore A. The empty space was precisely adjusted to the staff of the object to be printed.





**Tampo-Technik GmbH**

In der Helle 14

D-58566 Kierspe

Germany

Telefon: +49 (0) 2359 - 290436

Telefax: + 49 (0) 2359 - 290442

[info@tampotechnik.de](mailto:info@tampotechnik.de)

[www.tampotechnik.de](http://www.tampotechnik.de)