



CRIMPKONTAKTE

LOSE UND IN BANDFORM

CRIMP CONTACTS

LOOSE AND IN BANDOLIER FORM



FIRMENPROFIL

COMPANY PROFILE

UNSERE PRODUKTE

- Steckverbindersysteme mit Schneidklemm-, Crimp- oder Lötanschluss
- Lötfreie Verbinder
- Crimpkontakte
- Kundenspezifische Sonderentwicklungen
- Verarbeitungssysteme für alle STOCKO-Produkte: Handzangen, Halb- und Vollautomaten

UNSERE MÄRKTE

- Hausgerätektechnik
- Heizungstechnik
- Industrie
- Automotive
- Distribution

WERKE

- Wuppertal / Deutschland
- Hellenthal / Deutschland
- Andlau / Frankreich
- Sokolov / Tschechien
- Shanghai / China

GESICHERTE QUALITÄT

ZERTIFIZIERTE INTEGRIERTE MANAGEMENTSYSTEME

- Zertifiziert nach
ISO 9001
ISO 14001
IATF 16949

STOCKO CONTACT Deutschland, Frankreich

Zertifiziert nach
ISO 50001

STOCKO CONTACT Hellenthal / Deutschland

OUR PRODUCTS

- Multi-way connector systems with terminations for insulation displacement crimping or soldering
- Solderless terminals
- Crimp contacts
- Customers' special products
- Terminating systems for all STOCKO products: Hand tools, semi- and fully automated machines

OUR MARKETS

- Domestic appliances industry
- Heating industry
- Industry
- Automotive
- Distribution

FACTORIES

- Wuppertal / Germany
- Hellenthal / Germany
- Andlau / France
- Sokolov / Czech Republic
- Shanghai / China

ASSURED QUALITY

CERTIFIED INTEGRATED MANAGEMENT SYSTEMS

- Certified according to
ISO 9001
ISO 14001
IATF 16949

STOCKO CONTACT Germany, France

Certified according to
ISO 50001

STOCKO CONTACT Hellenthal / Germany

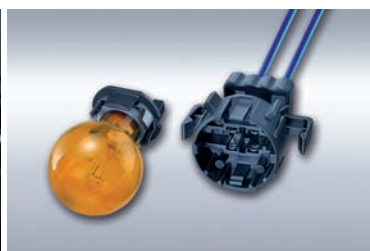

■ WUPPERTAL
Deutschland / Germany



■ HELLENTHAL
Deutschland / Germany



■ ANDLAU
Frankreich / France



■ GRÜNDUNG

- 1901 in Wuppertal

FOUNDED

- 1901 in Wuppertal

■ MITARBEITER WELTWEIT

- 600

EMPLOYEES WORLD-WIDE

- 600

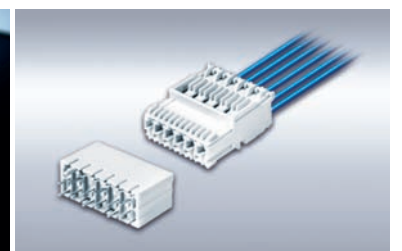
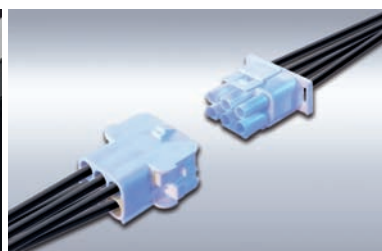

Sichere Kontakte. Weltweit. Secure Connections. World-wide.

STOCKO zählt heute zu den führenden europäischen Anbietern von elektromechanischen Bauelementen. Aus gutem Grund. Denn seit mehr als hundert Jahren konzentrieren wir uns bei der täglichen Arbeit auf das Wesentliche: die Zufriedenheit unserer Kunden. Es ist nicht selbstverständlich, über eine so lange Zeit allen Erwartungen gerecht zu werden. Die Bauelementebranche ist eine Schlüsselindustrie, die keine Fehler verzeiht und bei der die Kundenwünsche so vielfältig wie anspruchsvoll sind. Sie fordern immer wieder unseren ganzen Einsatz – angefangen bei Forschung und Entwicklung, bis hin zu Logistik und Vertrieb. Aus diesem Grund haben wir unsere Kunden von Anfang an in zahlreiche Prozesse, vor allem aber in die Qualitätssicherung eingebunden. Nur so können wir innovative Entwicklungen und Verfahrenstechniken auf den Weg bringen. Und nur so können wir auf Dauer unsere Produkte auf konsequent hohem Niveau anbieten. Produkte, die sich in der Heizungssteuerung und in Getränkeautomaten genauso finden wie im Geschirrspüler oder im Automobil. Wenn wir bei STOCKO also von sicheren Kontakten sprechen, dann deshalb, weil in jedem unserer Steckverbinder die Überzeugung mitschwingt, dass gute Verbindungen immer auch Vertrauenssache sind.

Today, STOCKO is one of the leading European manufacturers of electro-mechanical components; for very good reasons, because, for more than one hundred years, we are focussed in our daily work on the most important object, to satisfy our customers. Of course, it is not easy to meet these expectations over such a long period of time. Electronic component manufacturing is a key industry that does not tolerate mistakes, and customers' requirements are very complex and challenging. Again and again, they demand our full efforts beginning with research and development and finally in logistics and marketing. Hence we invite our customers' involvement in numerous stages of production processes but above all with regard to quality assurance, right from the beginning, and thus make sure that we continue to offer our products at a high quality level. Products that can be found equally in heating controls, drink dispensing machines, dish washers or motor cars. If, at STOCKO, we talk of secure connections then for this reason that in every one of our connectors an element of conviction reverberates that good connections are always a matter of trust.

Artikelverzeichnis Index of parts	4 - 5
Technische Informationen Technical informations	6
Freigaben Approvals	7 - 9
Vergleichstabellen Cross-reference lists	10 - 11
Flachsteckhülsen Receptacles	12 - 21
Flachstecker Tabs	22 - 24 / 29 - 33
Leiterplatten-Kontakte Printed boards contacts	25 - 28
Krallenkabelschuhe Open barrel terminals	34 - 38
Aderendhülsen End splices	39 - 43
Rundsteckhülsen Sockets	44 - 45
Rundstifte Circular pins	46
Sonderanschlußteile Special connectors	47
Isolierkörper Insulation housings	48 - 60
Verarbeitungstechnik Terminating technology.....	61 - 62
Crimp-Qualitäts-Übersicht Crimp-quality-chart	63
Allgemeine Sicherheitshinweise General safety informations	64 - 65

Kundenzeichnungen und technische Datenblätter aller Produkte erhalten Sie auf Anfrage.
Customer drawing and data sheet for all products on request.

Technische Änderungen vorbehalten.
We reserve the right to alter technical details.
WEEE-Reg.-Nr. DE 14484959



Spulen / Spools Ø: 286 mm / 360 mm



Spulen / Spools Ø: 500 mm



Spulen / Spools Ø: 595 mm



Spulen / Spools Ø: 600 mm / 640 mm

Artikel-Nummer Part number	Spulen Ø Spools Ø mm	Seite Page
-------------------------------	----------------------------	---------------

600		
649 / -G		48
650.100 / -G		48
657.100 / -G		48
658.100 / -G		49
677 / -G		51
678.100 / -B		49
679.200 / -G		49
680 / -G		50
681 / -G		48
683.002 / -G		49
688-002		52
688-003		52
688-004		52
688-005		52
688-006		52
688-007		52
688-008		52
688.400-002		52
688.400-003		52
688.400-004		52
688.400-005		52
688.400-006		52
688.400-007		52
688.400-008		52
694 / -G		50
699-002		53
699-003		53
699-004		53
699-005		53
699-006		53
699-007		53
699-008		53

700		
700/1-4		55
701 / -G		54
718.100		54
727.001		54
727.002		54
728		54
761 / -G		50
777 / -G		51
788-002		51
788-003		51
788-004		51
788-005		51
788-006		51
798-003-025-960 / -G		53
798-005-020-960		53

2000		
2023.100 / -G		55
2023.200 / -G		55
2025.100 / -G		56
2025.200 / -G		56
2026.100 / -G		58
2026.200 / -G		58
2027.100 / -G		57

Artikel-Nummer Part number	Spulen Ø Spools Ø mm	Seite Page
-------------------------------	----------------------------	---------------

2027.200 / -G		57
2028.100 / -G		58
2028.110 / -G		59
2028.200 / -G		59
2028.300		58
2029		60
2029.100		60
2029.200		60
2041.100 / -G		57
2041.200 / -G		57

5000		
5889		24

5900		
5920.003	360	26
5920.004	360	26

6000		
6006	500	28
6006.002	500	28
6006.100	500	28
6007.002	500	28
6008	500	27
6008.001	500	27
6008.002	500	27
6008.003	500	27
6015		32
6015 VS		29
6015.001		29
6015.002		30
6015.003		30
6015.045		32
6015.090		32
6015.145		30
6015.190		30
6015.245		29
6015.290		29
6015.345		29
6015.390		30
6015.445		30
6015.490		29
6015.545		30
6015.590		30
6015.645		29
6015.690		29
6015.745		30
6015.790		30
6015.845		29
6015.890		29
6044.001		26
6045		27
6059		31
6059.645		31
6059.690		31
6080		31
6080.045		31
6080.090		31

Artikel-Nummer Part number	Spulen Ø Spools Ø mm	Seite Page
-------------------------------	----------------------------	---------------

6100		
6129		33
6129/2		33
6129.045		33
6129.045/3		33
6129.075/2		33
6129.090		33
6129.090/2		33
6129.090/3		33
6199	360	26

6200		
6201	500	28

7200		
7206	286	35
7207	286	35
7208	286	36
7209	286	36

7600		
7603.028	286	15
7603.105	286	15
7603.108	286	15
7604.001	286	15
7604.258	286	15
7605	286	12
7605.001	286	12
7606	286	12
7606.001	286	12
7607	286	12
7607.001	286	12
7630.158	600	19
7631	600	19
7631.001	600	19

7700		
7716.001	286	35
7716.002	286	37
7727	286	34
7735.001	286	41
7738	286	38
7770	286	42
7771	286	42
7779	286	34
7785	286	12
7785.001	286	12
7785.002	286	12
7785.003	286	12
7785.055	286	12
7785.058	286	12
7788	360	36
7788.001	360	37
7791	286	41
7791.001	286	41
7792.002	286	39
7800		
7806	286	42
7813	286	35

Artikel-Nummer Part number	Spulen Ø Spools Ø mm	Seite Page
-------------------------------	----------------------------	---------------

7825.001	286	39
7830	286	38
7830.001	286	38
7831.010	286	24
7831.011	286	24
7832	286	42
7833.010	286	24
7833.011	286	24
7835	286	46
7836	286	44
7837	286	41
7838	286	39
7840	286	24
7841	286	24
7843	286	38
7843.001	286	38
7849	286	40
7858	286	19
7858.001	286	19
7861.003	286	46
7877	286	36
7881	286	35
7881.001	286	37
7884.001	360	43
7884.003	360	43
7884.004	360	43
7894	286	41

7900		
7900	286	18
7901	286	18
7908	286	40
7912	286	41
7916	286	19
7916.001	286	19
7918.001	600	25
7918.002	600	25
7923.002	286	37
7929	286	40
7930	286	22
7936.002	286	15
7936.003	286	15
7942	286	29

Artikel-Nummer Part number	Spulen Ø Spools Ø mm	Seite Page
-------------------------------	----------------------------	---------------

7944.010	286	18
7944.258	286	18
7958	286	22
7960.020	286	21
7961.020	286	21
7984	600	15
7984.001	600	15
7990	286	13
7990.001	286	13
7990.055	286	13
7990.058	286	13
7994.002	640	44
7994.003	640	44
7995.003	286	44
7995.005	286	44
7999	286	40

8000		
8006	286	41
8007.001	600	47
8028	286	17
8028.001	286	17
8028.002	286	17
8028.003	286	17
8029	286	17
8029.001	286	17
8029.2258	286	17
8039.001	286	22
8039.003	286	22
8043	286	23
8047	286	21
8048	286	21
8059	640	39
8061	600	42
8064	286	15
8068	600	19
8069	286	45
8069.001	286	45
8069.002	286	45

8100		
8100	286	13
8100.001	286	13

Artikel-Nummer Part number	Spulen Ø Spools Ø mm	Seite Page
-------------------------------	----------------------------	---------------

8100.002	286	13
8100.003	286	13
8100.2055	286	13
8100.2058	286	13
8110	286	44
8110.001	286	44
8113.105	600	13
8113.108	600	13
8113.155	600	13
8115	286	18
8121.020	286	45
8121.022	286	45
8121.025	286	45
8121.115	286	45
8126.010	286	21
8131	286	43
8131.001	286	43
8134.010	286	37
8136	286	20
8137	286	20
8138	286	18
8138.108	286	18
8152	286	18
8165.108	286	23
8168.055	286	16
8168.058	286	16
8168.155	286	16
8168.158	286	16
8178.258	286	21
8178.308	286	21
8178.1108	286	21
8178.1258	286	21
8185	600	45
8186.155	286	16
8186.158	286	16

8200		
8200	360	36
8201	360	36
8202	360	35
8203	360	36
8204	360	36
8205.1158	286	22

Artikel-Nummer Part number	Spulen Ø Spools Ø mm	Seite Page
-------------------------------	----------------------------	---------------

8220.1158	286	20
8236	286	39
8238.158	286	20
8238.258	286	20
8240.158	286	20
8240.258	286	20
8240.1158	286	20
8240.1258	286	20
8260.155	286	19
8260.158	286	19
8260.258	286	19
8261.055	286	14
8261.058	286	14
8261.105	286	14
8261.108	286	14
8261.2055	286	14
8261.2058	286	14
8261.2105	286	14
8261.2108	286	14
8270.055	286	16
8270.058	286	16
8270.155	286	16
8270.158	286	16
8270.255	286	16
8270.258	286	16
8280.1055	286	14
8280.1058	286	14
8280.1105	286	14
8280.1108	286	14

8400		
8412	286	41

**Abspulrichtung
für Quertransport**

**Direction of transverse
transport**

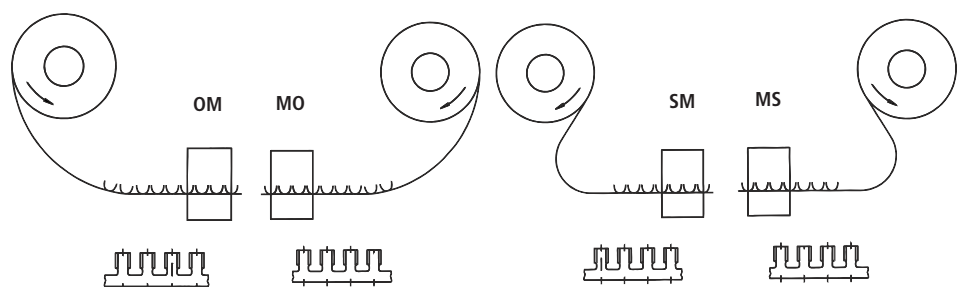

WERKSTOFFE UND OBERFLÄCHEN

Die eingesetzten Werkstoffe bestimmen das Verhalten und die Eigenschaften der Kontakte. Festigkeit, Federeigenschaften, elektrische Leitfähigkeit und Temperaturverhalten sind wesentliche Kriterien bei der Bewertung der Anwendungen. Messing, Zinnbronze und Stahl sind die gebräuchlichsten Grundmaterialien. Verschiedene Oberflächenbehandlungen erweitern den Anwendungsbereich bei speziellen Anforderungen. Sondermaterialien (z. B. Neusilber) auf Anfrage.

Werkstoff	Zulässige Grenztemperatur	Anwendungsbereich
Messing (CuZn) blank verzinkt (Sn) versilbert (Ag)	110 °C 120 °C 130 °C	Nur für günstige Umgebungsbedingungen, Korrosionsanfällig. Verzinnete Komponenten ergeben gute Leistungen bei höheren Temperaturen und schützen vor Korrosion. Versilberte Komponenten eignen sich für höchste Betriebstemperaturen bei höherer Strombelastung für Messing.
Zinnbronze (CuSn) blank verzinkt (Sn) versilbert (Ag)	120 °C 130 °C 150 °C	Unter korrosiven Bedingungen stabiler als Messing. Verzinnete Komponenten ergeben bei höheren Temperaturen verbesserten Korrosionsschutz. Versilberte Komponenten eignen sich für höchste Betriebstemperaturen bei höherer Strombelastung für Zinnbronze.
Neusilber (CuNiZn) blank	210 °C	Gute Korrosionsbeständigkeit. Erhöhte Festigkeit gegenüber Messing. Hoher elektrischer Widerstand, geringe Wärmeleitfähigkeit.
Stahl (Fe) vernickelt (Ni)	300 °C	Vernickelte Stahlkomponenten ergeben beste zuverlässige Verbindungen bei höheren Temperaturen.

MATERIALS AND SURFACE FINISHES

The materials used determine the performance and properties of the contacts. Strength, elasticity, electric conductivity and thermal performance are major criteria when it comes to rating different applications. Brass, phosphor bronze and steel are the most common base materials. Different surface finishes extend the application range for specific requirements. Special materials (e. g. nickel silver) on request.

Material	Max. temperature	Application range
Brass (CuZn) unplated tin plated (Sn) silver plated (Ag)	110 °C 120 °C 130 °C	Only for favourable environmental conditions. Susceptible to corrosion. Tin plated components perform well at higher temperatures and are resistant to corrosion. Silver plated components are suitable for highest operating temperatures coupled with higher current loads for brass.
Phosphor bronze (CuSn) unplated tin plated (Sn) silver plated (Ag)	120 °C 130 °C 150 °C	Under corrosive conditions more stable than brass. Tin plated components offer improved resistance to corrosion at higher temperatures. Silver plated components are suitable for highest operating temperatures coupled with higher current loads for tin bronze.
Nickel silver (CuNiZn) unplated	210 °C	Good resistance to corrosion. Stronger than brass. High electric resistance, low thermal conductivity.
Steel (Fe) nickel plated (Ni)	300 °C	Nickel plated steel components produce the most reliable connections at higher temperatures.

WERKSTOFFDATEN FÜR ISOLIERKÖRPER

MATERIAL DATA FOR INSULATION HOUSINGS

Werkstoff Material	Temperatur Index nach UL, Details siehe UL-Listing Temperature index acc. to UL, details see UL list
PA 66-V2	- 40 °C + 130 °C
PA 6/66-V0	- 40 °C + 140 °C
PA 46-V2	- 40 °C + 150 °C
PA 6-V2 nach / according to IEC 60335 (auf Anfrage / on request)	- 40 °C + 130 °C
PPS V0 nach / according to IEC 60335	- 40 °C + 240 °C
PBT V0	- 40 °C + 130 °C

VDE-GEPRÜFTE CRIMPKONTAKTE
VDE TESTED CRIMP CONTACTS

Artikel- Nummer Part number	CuZn blank unplated	CuZn verzinkt tin plated	CuSn blank unplated	CuSn verzinkt tin plated	Fe vernickelt nickel plated	CuNiSi blank unplated	CuNiSi verzinkt tin plated	CuNiZn blank unplated
RSB 7604.258					•			
RMB 7840		•						
RMB 7831.010		•						
RSB 7900	•							
RSB 7944.010	•	•	•	•	•		•	
RSB 7960.020	•	•						
RSB 7961.020	•	•						
RSB 8028		•						•
RSB 8047	•	•	•	•				
RSB 8048	•	•	•	•				
RBB 8110	•				•			
RFB 8121.020					•			
RFB 8121.025					•			
RSB 8138.108	•	•			•			
RMB 8165.108		•						
RSB 8168.055	•	•						
RSB 8168.058	•	•						
RSB 8168.155	•	•						
RSB 8168.158	•	•						
RSB 8178.108	•	•						•
RSB 8178.258	•	•						•
RSB 8186.155	•	•			•			
RSB 8186.158	•	•			•			
RSB 8220.1158					•			
RSB 8238.158	•	•			•			
RSB 8238.258	•	•			•			
RSB 8240.158	•	•			•			
RSB 8240.258	•	•			•			
RSB 8240.1158					•			
RSB 8260.158	•	•			•			
RSB 8260.258	•	•			•			
RSB 8270.158	•	•			•			
RSB 8270.258	•	•			•			

STOCKO-Produkte werden in unseren Prüflaboratorien laufend vielfältigen Prüfungen unterzogen. VDE-, UL- und weitere Freigaben für die wichtigen STOCKO-Artikel werden regelmäßig ergänzt. UL-Freigaben und eine einwandfreie Verdringung unserer Produkte sind nur dann gewährleistet, wenn die Verarbeitung auf STOCKO-Werkzeugen erfolgt.

STOCKO products are fully tested at our laboratories. VDE, UL and other approvals for the main STOCKO items are regularly updated. UL approvals and correct crimping only ensured on products crimped with STOCKO applicators.

UL / ULC-FREIGABEÜBERSICHT
FÜR CRIMPKONTAKTE
INDEX UL / ULC APPROVALS
FOR CRIMP CONTACTS

Artikel-Nummer Part number	CuZn blank unplated	CuZn verzinkt tin plated	CuSn blank unplated	CuSn verzinkt tin plated	Fe vernickelt nickel plated	CuNiSi blank unplated	CuNiSi verzinkt tin plated	UL File
RSB 7206					•			E177431
RSB 7605	•	•						E118944
RSB 7605.001	•	•						E118944
RSB 7606.001	•	•						E118944
RSB 7607	•							E118944
RSB 7630.001	•	•	•		•			E118944
RSB 7630.158	•	•	•	•	•			E118944
RSB 7631	•	•	•		•			E118944
RSB 7631.001	•	•	•		•			E118944

UL / ULC-FREIGABEÜBERSICHT FÜR CRIMPKONTAKTE

INDEX UL / ULC APPROVALS FOR CRIMP CONTACTS

Artikel-Nummer Part number	CuZn blank unplated	CuZn verzinkt tin plated	CuSn blank unplated	CuSn verzinkt tin plated	Fe vernickelt nickel plated	CuNiSi blank unplated	CuNiSi verzinkt tin plated	CuNiZn	UL File
RSB 7785	●	●	●		●				E118944
RSB 7785.001	●	●			●				E118944
RSB 7785.002	●	●			●				E118944
RSB 7785.003	●	●			●				E118944
RSB 7785.055	●	●			●				E118944
RSB 7785.058	●	●			●				E118944
RSB 7788	●	●	●	●					E177431
RSB 7792.002	●	●			●				E177431
RMB 7831.010	●	●	●						E118944
RMB 7831.011	●	●	●						E118944
RSB 7832	●	●							E177431
RMB 7833.010	●	●	●						E118944
RMB 7833.011	●	●	●						E118944
RSB 7849	●	●			●				E177431
RSB 7858	●	●							E118944
RSB 7858.001	●	●							E118944
RSB 7894	●	●							E177431
RSB 7900	●	●	●	●	●				E118944
RSB 7901	●	●	●	●	●				E118944
RSB 7923.002	●	●	●	●	●				E177431
RSB 7944.010	●	●	●	●	●		●		E118944
RSB 7944.258	●	●							E118944
RMB 7958	●	●							E118944
RSB 7960.020	●	●	●	●				●	E118944
RSB 7961.020	●	●	●	●				●	E118944
RSB 7984	●	●			●				E118944
RSB 7990	●	●							E118944
RSB 7990.001	●	●							E118944
RBB 7995.003					● (X5CrNi)				E118944
RSB 8028	●	●							E118944
RSB 8028.001	●	●							E118944
RSB 8029	●	●							E118944
RSB 8029.001	●	●							E118944
RSB 8047	●	●							E118944
RSB 8100.2055	●				●				E118944
RFB 8121.020					●				E118944
RFB 8121.025					●				E118944
RSB 8126.010	●	●	●	●					E118944
RSB 8138	●	●	●	●	●				E118944
RSB 8152				●	●				E118944
RMB 8165.108	●	●							E118944
RSB 8168.055	●	●							E118944
RSB 8168.058	●	●							E118944
RSB 8168.155	●	●							E118944
RSB 8168.158	●	●							E118944
RSB 8178.108	●	●							E118944
RSB 8178.258	●	●							E118944
RSB 8178.308	●	●							E118944
RSB 8186.155	●	●			●				E118944
RSB 8186.158	●	●			●				E118944
RSB 8238.158	●	●			●				E118944
RSB 8238.258	●	●			●				E118944
RSB 8240.158	●	●			●				E118944
RSB 8240.258	●	●			●				E118944
RSB 8260.158	●	●	●	●	●				E118944
RSB 8260.258	●	●	●	●	●				E118944
RSB 8270.158	●	●			●				E118944
RSB 8270.258	●	●			●				E118944

VDE-Freigabeübersicht für Isolierkörper

Index VDE approvals
for insulation housings

Artikel-Nummer Part number	Farbe Colour	Material Material	Brennbarkeitsklasse Flammability class		Material Material	Brennbarkeitsklasse nach Flammability class to V2 IEC 60335 no flame	UL File
			V0	V2			
EH 688-00X	natur	PA 66	●		PA 6	●	
EH 688.400-00X	Farben auf Anfrage	PA 66	●		PA 6	●	
EH 694	natural	PA 66	●	●			
EH 699	colors on request				PA 6	●	
EH 718.100					PA 6	●	
EH 700	schwarz, black	PPS	●				

UL-Freigabeübersicht für Isolierkörper

Index UL approvals
for insulation housings

EH 649		PA 66	●	●	PA 6	●	E306845
EH 650.100		PA 66	●	●	PA 6	●	E306845
EH 650.200		PA 66	●	●	PA 6	●	E306845
EH 657.100		PA 66	●	●	PA 6	●	E306845
EH 658.100		PA 66		●	PA 6	●	E306845
EH 677		PA 66	●	●			E306845
EH 678.100		PA 66		●	PA 6	●	E306845
EH 679.200		PA 66	●	●	PA 6	●	E306845
EH 680		PA 66	●	●	PA 6	●	E306845
EH 681		PA 66	●	●	PA 6	●	E306845
EH 683.002		PA 66	●	●	PA 6	●	E306845
EH 688-00X	natur	PA 66	●		PA 6	●	E306640
EH 688.400-00X	Farben auf Anfrage	PA 66	●		PA 6	●	E306640
EH 694	natural	PA 66	●	●	PA 6		E191950
EH 699	colors on request				PA 6	●	E306640
EH 701		PA 66		●	PA 6	●	E306845
EH 718.100					PA 6	●	E306640
EH 777		PA 66	●	●			E306845
EH 798.003					PA 6	●	E306845
EH 798.005		PA 66	●				E306845
VV 2023.100		PA 66	●	●	PA 6	●	E306845
VV 2023.200		PA 66	●	●	PA 6	●	E306845
VV 2025.100		PA 66		●	PA 6	●	E306845
VV 2025.200		PA 66		●	PA 6	●	E306845
VV 2026.100		PA 66		●	PA 6	●	E306845
VV 2026.200		PA 66		●	PA 6	●	E306845
VV 2027.100		PA 66		●	PA 6	●	E306845
VV 2027.200		PA 66		●	PA 6	●	E306845
VV 2028.100		PA 66		●	PA 6	●	E306845
VV 2028.110		PA 66		●	PA 6	●	E306845
VV 2028.200		PA 66		●	PA 6	●	E306845
VV 2029.100		PA 66		●	PA 6	●	E306845
VV 2029.200		PA 66		●	PA 6	●	E306845
VV 2041.100		PA 66		●	PA 6	●	E306845
VV 2041.200		PA 66		●	PA 6	●	E306845

STOCKO-Produkte werden in unseren Prüflaboratorien laufend vielfältigen Prüfungen unterzogen. VDE-, UL- und weitere Freigaben für die wichtigen STOCKO-Artikel werden regelmäßig ergänzt.

STOCKO products are fully tested at our laboratories. VDE, UL and other approvals for the main STOCKO items are regularly updated. UL approvals and correct crimping only ensured on products crimped with STOCKO applicators.

VERGLEICHSTABELLEN CROSS-REFERENCE LISTS

Umrechnung des Inch
Equivalents of an Inch

Übersicht der gängigen Leiter
nach VDE 0250 / 4.64

Cable chart of wire sizes to
VDE 0250 / 4.64 specification

Fraction inch	Decimal inch	Millimeter mm
1/64	.015625	0.397
1/32	.031250	0.794
3/64	.046875	1.191
1/16	.062500	1.588
5/64	.078125	1.984
3/32	.093750	2.381
7/64	.109375	2.778
1/8	.125000	3.175
9/64	.140625	3.572
5/32	.156250	3.969
11/64	.171875	4.366
3/16	.187500	4.763
13/64	.203125	5.159
7/32	.218750	5.556
15/64	.234375	5.953
1/4	.250000	6.350
17/64	.265625	6.747
9/32	.281250	7.144
19/64	.296875	7.541
5/16	.312500	7.938
21/64	.328125	8.334
11/32	.343750	8.731
23/64	.359375	9.128
3/8	.375000	9.525
25/64	.390625	9.922
13/32	.406250	10.319
27/64	.421875	10.716
7/16	.437500	11.113
29/64	.453125	11.509
15/32	.468750	11.906
31/64	.484375	12.303
1/2	.500000	12.700
33/64	.515625	13.097
17/32	.531250	13.494
35/64	.546875	13.891
9/16	.562500	14.288
37/64	.578125	14.684
19/32	.593750	15.081
39/64	.609375	15.478
5/8	.625000	15.875
41/64	.640625	16.272
21/32	.656250	16.669
43/64	.671875	17.066
11/16	.687500	17.463
45/64	.703125	17.859
23/32	.718750	18.256
47/64	.734375	18.653
3/4	.750000	19.050
49/64	.765625	19.447
25/32	.781250	19.844
51/64	.796875	20.241
13/16	.812500	20.638
53/64	.828125	21.034
27/32	.843750	21.431
55/64	.859375	21.828
7/8	.875000	22.225
57/64	.890625	22.622
29/32	.906250	23.019
59/64	.921875	23.416
15/16	.937500	23.813
61/64	.953125	24.209
31/32	.968750	24.606
63/64	.984375	25.003
1	1.000000	25.400

mm ²	Anzahl und Ø der Leiterdrähte No. and dia. of strands mm	Leiter-Ø Wire dia. mm max.
0,5	1 x 0,80	0,8
	7 x 0,30	0,9
	16 x 0,20	0,9
0,75	1 x 1,00	1,0
	7 x 0,37	1,1
1	24 x 0,20	1,2
	1 x 1,13	1,13
	7 x 0,43	1,3
	19 x 0,25	1,3
1,5	32 x 0,20	1,3
	1 x 1,38	1,38
	7 x 0,52	1,6
	21 x 0,30	1,6
2,5	30 x 0,25	1,7
	189 x 0,10	1,9
	1 x 1,78	1,78
	7 x 0,67	2,1
4	35 x 0,30	2,2
	50 x 0,25	2,2
	315 x 0,10	2,2
	1 x 2,26	2,26
6	19 x 0,52	2,7
	56 x 0,30	3,1
	511 x 0,10	3,0
	1 x 2,76	2,76
10	7 x 1,05	3,2
	19 x 0,64	3,3
	84 x 0,30	3,5
	756 x 0,10	3,7
16	1 x 3,57	3,57
	7 x 1,35	4,1
	19 x 0,80	4,3
	49 x 0,51	4,6
	80 x 0,40	5,0
16	1197 x 0,10	4,5
	1 x 4,52	4,52
	7 x 1,70	5,2
	37 x 0,75	5,6
	49 x 0,65	5,9
	128 x 0,40	6,0
2058 x 0,10	6,8	

Umrechnung der gängigen amerikanischen Leiter

Conversion table of American Wire Sizes

AWG #	Circ. Mils.	A = mm ²
26	238 - 300	0,12 - 0,15
24	315 - 477	0,16 - 0,24
22	600 - 750	0,30 - 0,38
20	1000 - 1200	0,51 - 0,61
18	1600 - 1900	0,81 - 0,96
16	2400 - 2830	1,22 - 1,43
14	3830 - 4500	1,94 - 2,28
12	6100 - 6700	3,09 - 3,40
10	9000 - 13100	4,56 - 6,64
8	13200 - 16900	6,69 - 8,56
6	22800 - 30900	11,55 - 15,66

AWG #	Circ. Mils.	A = mm ²
4	38900 - 49100	19,71 - 24,88
2	60100 - 66800	30,45 - 33,85
1	75800 - 84000	38,41 - 42,56
1/0	99100 - 105800	50,21 - 53,61
2/0	124900 - 133800	63,29 - 67,80
3/0	157600 - 168000	79,86 - 85,12
4/0	198700 - 212200	100,68 - 107,52
250 - 300 MCM	250000 - 300000	117 - 151
300 - 350 MCM	300000 - 350000	151 - 192
400 MCM	400000	205
500 - 600 MCM	500000 - 600000	252 - 304

AWG = American Wire Gauge

Circ. Mils.: Der Circ. Mils.-Wert eines Kreises mit d = 1 Mil. beträgt:
 1 x 1 = 1 Circ. Mil. (1 Mil. = 0,001 inch = 0,0254 mm)
 1 Circ. Mil. = 0,0005066 mm²
 1 mm² = 1973,51 Circ. Mils.

Formel zur Bestimmung des Leiterquerschnittes

$$A = \frac{d^2 \cdot \pi}{4} \times n$$

A = Leiterquerschnitt in mm²
 n = Anzahl Einzeldrähte

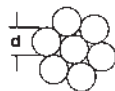

AWG = American Wire Gauge

Circular Mil Area (CMA): Area of a circle of 1 mil diameter
 1 x 1 = 1 Circ. Mil. (1 Mil. = 0.001 inch = 0.0254 mm)
 1 Circ. Mil. = 0.0005066 mm²
 1 mm² = 1973.51 Circ. Mils.

Formula to determine the wire size

$$A = \frac{d^2 \cdot \pi}{4} \times n$$

A = Wire size in mm²
 n = Number of strands

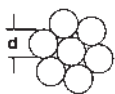

Anschlußbolzen Standard stud-bolts

DIN	USA	British Assoc.
M 2	1 = 1,9 mm	9 BA = 1,9 mm
	2 = 2,2 mm	8 BA = 2,2 mm
M 2,6	3 = 2,5 mm	7 BA = 2,5 mm
M 3	4 = 2,8 mm	6 BA = 2,8 mm
	5 = 3,2 mm	5 BA = 3,2 mm
M 3,5	6 = 3,5 mm	4 BA = 3,5 mm
M 4	8 = 4,2 mm	3 BA = 4,2 mm
M 5	10 = 4,8 mm	2 BA = 4,8 mm
M 6	12 = 5,5 mm	1 BA = 5,5 mm
	14 = 6,1 mm	0 BA = 6,1 mm
	1/4" = 6,35 mm	1/4" = 6,35 mm

DIN	USA	British Assoc.
M 8	5/16" = 7,9 mm	5/16" = 7,9 mm
M 10	3/8" = 9,5 mm	3/8" = 9,5 mm
M 12	7/16" = 11,1 mm	7/16" = 11,1 mm
	1/2" = 12,7 mm	1/2" = 12,7 mm
M 16	5/8" = 15,8 mm	5/8" = 15,8 mm
M 20	3/4" = 19,0 mm	3/4" = 19,0 mm
M 26	1" = 25,4 mm	1" = 25,4 mm

FLACHSTECKHÜLSEN RECEPTACLES

■ Flachsteckhülsen für Steckbreite 2,8 mm

■ Receptacles for tab width 2,8 mm

Bauform Q = Quertransport L = Längstransport Supply condition Q = transverse transport / Side feed L = longitudinal transport / End feed	Artikel-Nummer Part number	DIN	Frei- gaben- s. Seiten 7/8 Appro- vals s. page 7/8	Leiter- quer- schnitt Wire size mm ² AWG	Material	Veredlung			Länge		Steck- dicke Tab thick- ness mm	Rast- posi- tion Inden- tation	Verp.-Einh. Bandform Packing unit Chain form x 1000
						blank	Sn	Ni	L 1 mm	L 2 mm			
						un- plated	Sn	Ni					

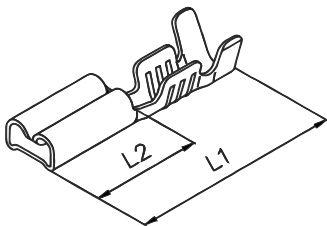

L

RSB 7605 F 2,8-0,25				0,14-0,34	CuSn	○	○		12,5	5,0	0,8	DIN	25
	●			26-22	CuZn	●	●						
RSB 7605.001 F 2,8-0,25				0,14-0,34	CuSn	○	○		12,5	5,0	0,5	DIN	25
	●			26-22	CuZn	●	●						
RSB 7607 F 2,8-0,5				0,25-0,75	CuSn	○	○		12,5	5,0	0,8	DIN	25
	●			24-20	CuZn	●	●						
RSB 7607.001 F 2,8-0,5				0,25-0,75	CuSn	●	○		12,5	5,0	0,5	DIN	25
				24-20	CuZn	○	○						
RSB 7606 F 2,8-1		46330 T2		0,5-1	CuSn	●	○		12,5	5,0	0,8	DIN	18
		A 2,8-1		20-18	CuZn	●	●						
RSB 7606.001 F 2,8-1				0,5-1	CuSn	○	○		12,5	5,0	0,5	DIN	18
	●			20-18	CuZn	●	●						
RSB 7785.058 F 2,8-0,5	●			0,22-0,5	CuSn	○	○		14,0	6,3	0,8	DIN	18
	●			24-20	CuZn	○	○						
RSB 7785.055 F 2,8-0,5	●			0,22-0,5	CuSn	○	○		14,0	6,3	0,5	DIN	18
	●			24-20	CuZn	○	○						
RSB 7785 F 2,8-1	●			0,5-1	CuSn	○	○		14,0	6,3	0,5	IEC	18
	●			20-18	CuZn	●	●						
RSB 7785.001 F 2,8-1	●			0,5-1	CuSn	○	○		14,0	6,3	0,8	IEC	18
	●			20-18	CuZn	●	●						
RSB 7785.002 F 2,8-1	●			0,5-1	CuSn	○	○		14,0	6,3	0,5	DIN	18
	●	46247 T1		20-18	CuZn	●	●						
RSB 7785.003 F 2,8-1	●			0,5-1	CuSn	●	●		14,0	6,3	0,8	DIN	18
	●	46247 T1		20-18	CuZn	●	●						

● Standard-Artikel / Standard parts ○ lieferbar auf Anfrage / available on request

■ Flachsteckhülsen für Steckbreite 2,8 mm

■ Receptacles for tab width 2,8 mm

Bauform Q = Quertransport L = Längstransport Supply condition Q = transverse transport / Side feed L = longitudinal transport / End feed	Artikel-Nummer Part number	DIN	Frei- gaben- s. Seiten 7/8 Appro- vals s. page 7/8	Leiter- quer- schnitt Wire size mm ² AWG	Material	Veredlung			Länge		Steck- dicke Tab thick- ness mm	Rast- posi- tion Inden- tation	Verp.-Einh. Bandform Packing unit Chain form x 1000
						blank	Sn	Ni	L 1 mm	L 2 mm			
						un- plated	Sn	Ni					

Nicht entriegelbar
Permanently engaged

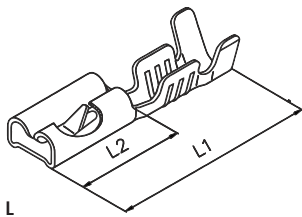

L

RSB 7990.058 F 2,8-0,5	0,22-0,5	CuSn				13,8	6,4	0,8		18
	24-20	CuZn	○	●						
		Fe			○					
RSB 7990.055 F 2,8-0,5	0,22-0,5	CuSn				13,8	6,4	0,5		18
	24-20	CuZn	○	○						
		Fe			○					
RSB 7990 F 2,8-1	0,5-1	CuSn				13,8	6,4	0,8		18
	20-18	CuZn	●	○						
		Fe			○					
RSB 7990.001 F 2,8-1	0,5-1	CuSn				13,8	6,4	0,5		18
	20-18	CuZn	●	●						
		Fe			○					

Leicht aufsteckbar
Low insertion force

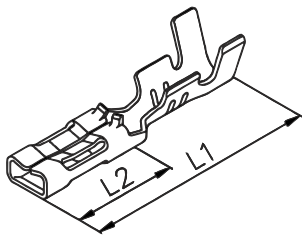

L

RSB 8100 F 2,8-1	0,5-1	CuSn	○	○		14,0	6,4	0,8	DIN	14
	20-18	CuZn	●	●						
		Fe			○					
RSB 8100.001 F 2,8-1	0,5-1	CuSn	○	○		14,0	6,4	0,5	DIN	14
	20-18	CuZn	○	●						
		Fe			○					
RSB 8100.002 F 2,8-1	0,5-1	CuSn	○	○		14,0	6,4	0,5	IEC	14
	20-18	CuZn	●	●						
		Fe			○					
RSB 8100.003 F 2,8-1	0,5-1	CuSn	○	○		14,0	6,4	0,8	IEC	14
	20-18	CuZn	●	●						
		Fe			○					
RSB 8100.2055 F 2,8-0,5	0,22-0,5	CuSn	○	○		14,0	6,4	0,5	IEC	14
	24-20	CuZn	●	○						
		Fe			○					
RSB 8100.2058 F 2,8-0,5	0,22-0,5	CuSn	○	○		14,0	6,4	0,8	IEC	14
	24-20	CuZn	○	○						
		Fe			●					

Timer-Kontakt
Timer contact

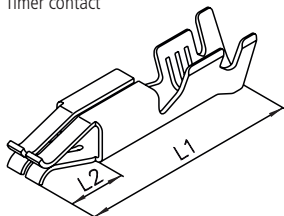

Q

RFB 8113.105 F 2,8-1 Für Gehäusemontage For housings	0,5-1	CuSn	○	○		18,7	5,0	0,5		4,5
	20-18	CuZn	○	●						
RFB 8113.108 F 2,8-1 Für Gehäusemontage For housings	0,5-1	CuSn	○	○		18,7	5,0	0,8		4,5
	20-18	CuZn	○	●						
RFB 8113.155 F 2,8-1,5 Für Gehäusemontage For housings	1-2,0	CuSn	○	○		18,7	5,0	0,5		4
	18-14	CuZn	○	●						

● Standard-Artikel / Standard parts ○ lieferbar auf Anfrage / available on request

FLACHSTECKHÜLSEN RECEPTACLES

■ Flachsteckhülsen für Steckbreite 2,8 mm

■ Receptacles for tab width 2,8 mm

Bauform Q = Quertransport L = Längstransport Supply condition Q = transverse transport / Side feed L = longitudinal transport / End feed	Artikel-Nummer Part number	DIN	Frei- gaben- s. Seiten 7/8 Appro- vals s. page 7/8 mm ² AWG	Leiter- quer- schnitt Wire size mm ² AWG	Material	Veredlung			Länge		Steck- dicke Tab thick- ness mm	Rast- posi- tion Inden- tation	Verp.-Einh. Bandform Packing unit Chain form x 1000
						blank	Sn	Ni	L 1 mm	L 2 mm			
						un- plated	Sn	Ni					

Für Gehäuse
For housings

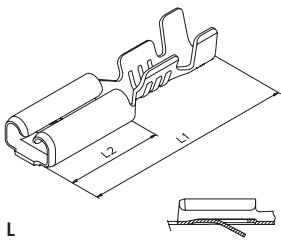

L

RSB 8280.1055 F 2,8-0,5	46340 T1	0,25-0,5	CuSn	●	○	14,0	6,0	0,5		19
		24-22	CuZn	●	○					
RSB 8280.1058 F 2,8-0,5	46340 T1	0,25-0,5	CuSn	●	○	14,0	6,0	0,8		19
		24-22	CuZn	●	●					
RSB 8280.1105 F 2,8-1	46340 T1	0,5-1	CuSn	●	○	14,0	6,0	0,5		14
		20-18	CuZn	●	○					
RSB 8280.1108 F 2,8-1	46340 T1	0,5-1	CuSn	●	○	14,0	6,0	0,8		14
		20-18	CuZn	●	●					

Verriegelung, leicht aufsteckbar
Self locking, low insertion force

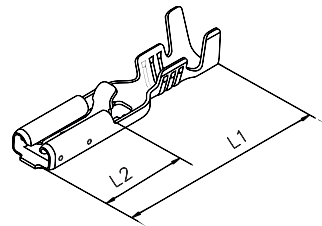

L

RSB 8261.055 F 2,8-0,5			>0,25-0,5 22-20	CuZn	○	●	17	6,2	0,5	DIN	15
RSB 8261.058 F 2,8-0,5			>0,25-0,5 22-20	CuZn	○	●	17	6,2	0,8	DIN	15
RSB 8261.105 F 2,8-1			0,5-1 20-18	CuZn	○	●	17	6,2	0,5	DIN	15
RSB 8261.108 F 2,8-1			0,5-1 20-18	CuZn	○	●	17	6,2	0,8	DIN	15
RSB 8261.2055 F 2,8-0,5			>0,25-0,5 22-20	CuZn	●	○	17	6,2	0,5	IEC	15
RSB 8261.2058 F 2,8-0,5			>0,25-0,5 22-20	CuZn	○	○	17	6,2	0,8	IEC	15
RSB 8261.2105 F 2,8-1			0,5-1 20-18	CuZn	●	○	17	6,2	0,5	IEC	15
RSB 8261.2108 F 2,8-1			0,5-1 20-18	CuZn	○	○	17	6,2	0,8	IEC	15

● Standard-Artikel / Standard parts ○ lieferbar auf Anfrage / available on request

■ Flachsteckhülsen für Steckbreite 4,8 mm

■ Receptacles for tab width 4,8 mm

Bauform Q = Quertransport L = Längstransport Supply condition Q = transverse transport / Side feed L = longitudinal transport / End feed	Artikel-Nummer Part number	DIN	Frei- gaben- s. Seiten 7/8 Appro- vals s. page 7/8	Leiter- quer- schnitt Wire size mm ² AWG	Material	Veredlung			Länge		Steck- dicke Tab thick- ness mm	Rast- posi- tion Inden- tation	Verp.-Einh. Bandform Packing unit Chain form x 1000
						blank	Sn	Ni	L 1 mm	L 2 mm			
						Finishing							
						un- plated	Sn	Ni					

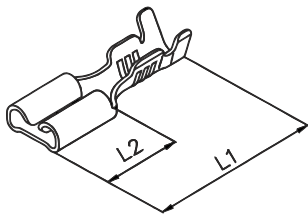

L

RSB 7603.028 F 4,8-0,2				0,14-0,34	CuSn	○	○		16,0	6,3	0,8	DIN	12
				24-22	CuZn	○	○						
					Fe			○					
RSB 7603.108 F 4,8-1	46247 T2 4,8-1			0,5-1	CuSn	○	●		16,0	6,3	0,8	DIN	10
				20-18	CuZn	●	●						
					Fe			●					
RSB 7603.105 F 4,8-1				0,5-1	CuSn	○	○		16,0	6,3	0,5	DIN	10
				20-18	CuZn	●	●						
					Fe			●					
RSB 7604.258 F 4,8-2,5	46247 T2 4,8-2,5			>1-2,5	CuSn	○	○		16,0	6,3	0,8	DIN	10
				16-14	CuZn	●	●						
					Fe			●					
RSB 7604.001 F 4,8-2,5				>1-2,5	CuSn	○	○		16,0	6,3	0,5	DIN	10
				16-14	CuZn	○	○						
					Fe			○					

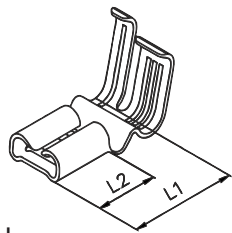

L

RSB 7936.002 F 4,8-1,5				0,5-1,5	CuSn	○	○		10,0	6,0	0,8	DIN	3
				20-16	CuZn	○	●						
					Fe			○					
RSB 7936.003 F 4,8-1,5				0,5-1,5	CuSn	○	○		10,0	6,0	0,5	DIN	3
				20-16	CuZn	●	●						
					Fe			○					

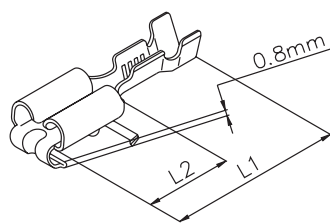

Q

RSB 7984 X 4,8-1,5				0,5-1,5	CuSn				16,0	6,0	0,8	DIN	2,5
				20-16	CuZn	●	●						
					Fe			●					
RSB 7984.001 X 4,8-1,5				0,5-1,5	CuSn				16,0	6,0	0,5	DIN	2,5
				20-16	CuZn	○	○						
					Fe			○					

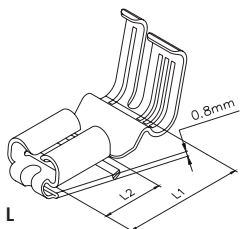

L

RSB 8064 X 4,8-1,5				0,5-1,5	CuSn				11,5	6,0	0,8	DIN	2,5
				20-16	CuZn	○	○						
					Fe								

● Standard-Artikel / Standard parts ○ lieferbar auf Anfrage / available on request

FLACHSTECKHÜLSEN RECEPTACLES

■ Flachsteckhülsen für Steckbreite 4,8 mm

■ Receptacles for tab width 4,8 mm

Bauform Q = Quertransport L = Längstransport Supply condition Q = transverse transport / Side feed L = longitudinal transport / End feed	Artikel-Nummer Part number	DIN	Frei- gaben- s. Seiten 7/8 Appro- vals s. page 7/8	Leiter- quer- schnitt Wire size mm ² AWG	Material	Veredlung			Länge		Steck- dicke Tab thick- ness mm	Rast- posi- tion Inden- tation	Verp.-Einh. Bandform Packing unit Chain form x 1000
						blank	Sn	Ni	L 1 mm	L 2 mm			
						un- plated	Sn	Ni					

Leicht aufsteckbar
Low insertion force

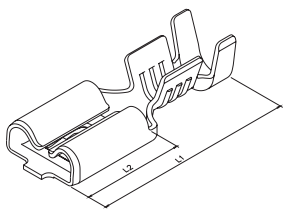

L

RSB 8270.058 F 4,8-0,5	0,22 - 0,5	CuSn	○	○	14,5	6,2	0,8	DIN	18
	24 - 20	CuZn	○	○					
		Fe		○					
RSB 8270.055 F 4,8-0,5	0,22 - 0,5	CuSn	○	○	14,5	6,2	0,5	DIN	18
	24 - 20	CuZn	○	○					
		Fe		○					
RSB 8270.158 F 4,8-1,5	0,75 - 1,5	CuSn	○	○	14,5	6,2	0,8	DIN	14
	18 - 16	CuZn	●	●					
		Fe		●					
RSB 8270.155 F 4,8-1,5	0,75 - 1,5	CuSn	○	○	14,5	6,2	0,5	DIN	14
	18 - 16	CuZn	○	○					
		Fe		○					
RSB 8270.258 F 4,8-2,5	1,5 - 2,5	CuSn	○	○	14,5	6,2	0,8	DIN	9
	16 - 14	CuZn	●	●					
		Fe		●					
RSB 8270.255 F 4,8-2,5	1,5 - 2,5	CuSn	○	○	14,5	6,2	0,5	DIN	9
	16 - 14	CuZn	○	○					
		Fe		○					

Leicht aufsteckbar
Low insertion force

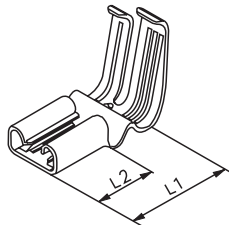

L

RSB 8186.158 F 4,8-1,5	0,5-1,5	CuSn	○	○	10,0	6,0	0,8	DIN	3
	20-16	CuZn	●	●					
		Fe		●					
RSB 8186.155 F 4,8-1,5	0,5-1,5	CuSn	○	○	10,0	6,0	0,5	DIN	3
	20-16	CuZn	●	●					
		Fe		●					

Verriegelbar, leicht aufsteckbar
Self locking, low insertion force

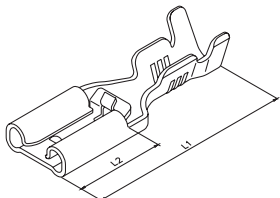

L

RSB 8168.058 F 4,8-0,5	0,22-0,75	CuSn	○	○	16,3	6,3	0,8	DIN	10
	24-20	CuZn	●	●					
		CuNiZn	○						
RSB 8168.055 F 4,8-0,5	0,22-0,75	CuSn	○	○	16,3	6,3	0,5	DIN	10
	24-20	CuZn	●	●					
		CuNiZn	○						
RSB 8168.158 F 4,8-1,5	>0,75-2,0	CuSn	○	○	16,3	6,3	0,8	DIN	10
	18-14	CuZn	●	●					
		CuNiZn	○						
RSB 8168.155 F 4,8-1,5	>0,75-2,0	CuSn	○	○	16,3	6,3	0,5	DIN	10
	18-14	CuZn	●	●					
		CuNiZn	○						

● Standard-Artikel / Standard parts ○ lieferbar auf Anfrage / available on request

■ Flachsteckhülsen für Steckbreite 4,8 mm

■ Receptacles for tab width 4,8 mm

Bauform Q = Quertransport L = Längstransport Supply condition Q = transverse transport / Side feed L = longitudinal transport / End feed	Artikel-Nummer Part number	Frei- gaben- s. Seiten 7/8 Appro- vals s. page 7/8	Leiter- quer- schnitt Wire size mm ² AWG	Material	Veredlung			Länge		Steck- dicke Tab thick- ness mm	Rast- posi- tion Inden- tation	Verp.-Einh. Bandform Packing unit Chain form x 1000
					blank	Sn	Ni	L 1 mm	L 2 mm			
					Finishing							
					un- plated							

Verriegelbar
Self locking

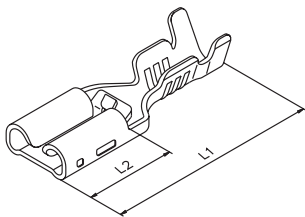

L

RSB 8028 F 4,8-1		0,5-1	CuSn	○	●		17,0	6,3	0,8	DIN	9
	●	20-18	CuZn	●	●	●					
			CuNiZn	○							
RSB 8028.001 F 4,8-1		0,5-1	CuSn	○	○		17,0	6,3	0,5	DIN	9
	●	20-18	CuZn	●	●						
			CuNiZn	○							
RSB 8029 F 4,8-2,5		1,5-2,5	CuSn	○	○		17,0	6,3	0,8	DIN	9
	●	16-14	CuZn	●	●						
			CuNiZn	○							
RSB 8029.001 F 4,8-2,5		1,5-2,5	CuSn	○	○		17,0	6,3	0,5	DIN	9
	●	16-14	CuZn	○	●						
			CuNiZn	○							

Nicht entriegelbar
Permanently engaged

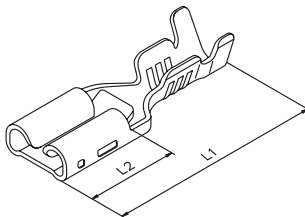

L

RSB 8028.002 F 4,8-1		0,5-1	CuSn	○	○		17,0	6,3	0,8	DIN	9
		20-18	CuZn	○	●						
			CuNiZn	○							
RSB 8028.003 F 4,8-1		0,5-1	CuSn	○	○		17,0	6,3	0,5	DIN	9
		20-18	CuZn	○	○						
			CuNiZn	○							
RSB 8029.2258 F 4,8-2,5		1,5-2,5	CuZn		●	○	17,0	6,3	0,8	DIN	9
		16-14									

● Standard-Artikel / Standard parts ○ lieferbar auf Anfrage / available on request

FLACHSTECKHÜLSEN RECEPTACLES

■ Flachsteckhülsen für Steckbreite 6,3 mm

■ Receptacles for tab width 6,3 mm

Bauform Q = Quertransport L = Längstransport Supply condition Q = transverse transport / Side feed L = longitudinal transport / End feed	Artikel-Nummer Part number	DIN	Frei- gaben- s. Seiten 7/8 Appro- vals s. page 7/8	Leiter- quer- schnitt Wire size mm ² AWG	Material	Veredlung			Länge		Steck- dicke Tab thick- ness mm	Rast- posi- tion Inden- tation	Verp.-Einh. Bandform Packing unit Chain form x 1000
						blank	Sn	Ni	L 1 mm	L 2 mm			
						un- plated	Sn	Ni					

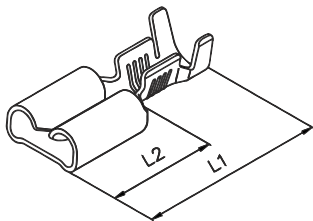

L

RSB 8115 F 6,3-0,2				0,12-0,35	CuSn	○	○	19,0	7,7	0,8	DIN	8
				26-22	CuZn	○	○					
					Fe		○					
RSB 7900 F 6,3-1	46247 T3 6,3-1			● 0,5-1,5	CuSn	●	●	19,0	7,7	0,8	DIN	8
				● 20-16	CuZn	●	●					
					Fe		●					
RSB 7901 F 6,3-2,5	46247 T3 6,3-2,5			● >1-2,5	CuSn	●	●	19,0	7,7	0,8	DIN	6
				● 16-14	CuZn	●	●					
					Fe		●					
RSB 8152 F 6,3-6	46247 T3 6,3-6			● 2,5-6	CuSn	○	●	19,0	7,7	0,8	DIN	5
				● 14-10	CuZn	●	●					
					Fe		●					

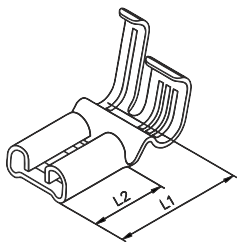

L

RSB 7944.010 F 6,3-1,5	46346			● 0,5-1,5	CuSn	○	○	11,5	7,7	0,8	DIN	2
				● 20-16	CuZn	●	●					
				●	Fe		●					
				●	CuNiSi	○	○					
RSB 7944.258 F 6,3-2,5				● 1,5-2,5	CuSn	○	○	11,5	7,7	0,8	DIN	1,8
				● 16-14	CuZn	●	●					
					Fe		●					

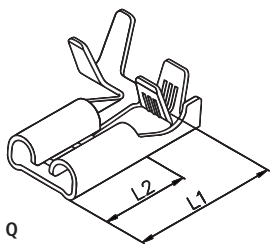

Q

RSB 8138 F 6,3-2,5	46346			● 1-2,5	CuSn	○	○	14,2	7,7	0,8	DIN	3,5
				● 16-14	CuZn	●	○					
				●	Fe		●					
RSB 8138.108 F 6,3-1	46346			● 0,5-1	CuSn			14,2	7,7	0,8	DIN	8
				● 20-18	CuZn	●	●					
				●	Fe		●					

● Standard-Artikel / Standard parts ○ lieferbar auf Anfrage / available on request

■ Flachsteckhülsen für Steckbreite 6,3 mm

■ Receptacles for tab width 6,3 mm

Bauform Q = Quertransport L = Längstransport Supply condition Q = transverse transport / Side feed L = longitudinal transport / End feed	Artikel-Nummer Part number	DIN	Freigaben s. Seiten 7/8 Approvals s. page 7/8	Leiterquer- schnitt Wire size mm ² AWG	Material	Veredlung			Länge		Steck- dicke Tab thick- ness mm	Rast- posi- tion Inden- tation	Verp.-Einh. Bandform Packing unit Chain form x 1000	Win- kel Angle
						blank	Sn	Ni	L 1 mm	L 2 mm				
						Finishing								
						un- plated	Sn	Ni						

Für Gehäuse
For housings

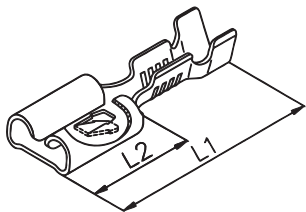

L

RSB 7916 F 6,3-1	46340 T3		0,5-1,5	CuSn	○	○	20	7,7	0,8		6	
	A 6,3-1		20-16	CuZn	●	●						
					Fe							
RSB 7916.001 F 6,3-1	46340 T3		0,5-1,5	CuSn	●	○	20	7,7	0,8	DIN	6	
	B 6,3-1		20-16	CuZn	●	●						
					Fe							
RSB 7858 F 6,3-2,5	46340 T3		1-<2,5	CuSn	○	○	20	7,7	0,8		6	
	A 6,3-2,5	●	18-14	CuZn	●	●						
					Fe							
RSB 7858.001 F 6,3-2,5	46340 T3		1-<2,5	CuSn	●	●	20	7,7	0,8	DIN	6	
	B 6,3-2,5	●	18-14	CuZn	●	●						
					Fe							

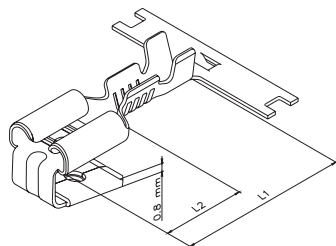

Q

RSB 7630.158 X 6,3-1,5 Mit einem Bandträger With a unique carrier strip	46345	●	0,5-1,5	CuSn	●	●	19,8	7,7	0,8	DIN	1,4	10°
	6,3-1	●	20-16	CuZn	●	●						
		●			Fe		●					
RSB 7631 X 6,3-2,5	46345	●	1-2,5	CuSn	○	●	19,8	7,7	0,8	DIN	1,3	10°
	6,3-2,5	●	16-14	CuZn	●	●						
		●			Fe		●					
RSB 7631.001 X 6,3-2,5	46345	●	1-2,5	CuSn	○	●	19,8	7,7	0,8	DIN	0,8	30°
	6,3-2,5	●	16-14	CuZn	○	○						
		●			Fe		●					

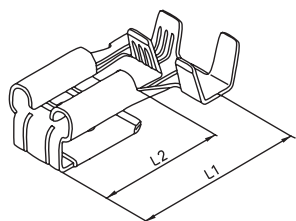

RSB 8068 F 6,3-2,5			>1-2,5 16-14	CuZn	○	●	14,8	7,6	0,8	DIN	1,5	

Leicht aufsteckbar
Low insertion force

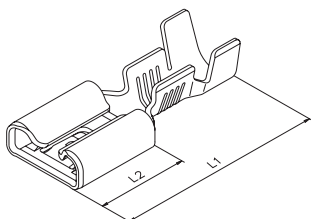

L

RSB 8260.155 F 6,3-1,5			0,5-1,5	CuSn			17,15	7,7	0,5	DIN	8	
			20-16	CuZn	●	○						
					Fe		○					
RSB 8260.158 F 6,3-1,5	●		0,5-1,5	CuSn	○	○	17,15	7,7	0,8	DIN	8	
	●		20-16	CuZn	●	●						
	●				Fe		○					
RSB 8260.258 F 6,3-2,5	●		>1-2,5	CuSn	○	○	17,15	7,7	0,8	DIN	6	
	●		16-14	CuZn	●	●						
	●				Fe		●					

● Standard-Artikel / Standard parts ○ lieferbar auf Anfrage / available on request

FLACHSTECKHÜLSEN RECEPTACLES

■ Flachsteckhülsen für Steckbreite 6,3 mm

■ Receptacles for tab width 6,3 mm

Bauform Q = Quertransport L = Längstransport Supply condition Q = transverse transport / Side feed L = longitudinal transport / End feed	Artikel-Nummer Part number	DIN	Frei- gaben- s. Seiten 7/8 Appro- vals s. page 7/8	Leiter- quer- schnitt Wire size mm ² AWG	Material	Veredlung			Länge		Steck- dicke Tab thick- ness mm	Rast- posi- tion Inden- tation	Verp.-Einh. Bandform Packing unit Chain form x 1000
						blank	Sn	Ni	L 1 mm	L 2 mm			
						un- plated	Sn	Ni					

Leicht aufsteckbar
Low insertion force

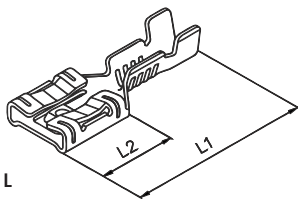

L

RSB 8137 F 6,3-0,5		0,2-0,5	CuSn	○	○		19,0	7,6	0,8	DIN	8
		24-20	CuZn	○	○	○					
			Fe			○					
RSB 8136 F 6,3-4		2,5-4	CuSn	○	○		19,0	7,6	0,8	DIN	4,5
		14-10	CuZn	○	○	○					
		*	Fe			●					
* Doppelcrimp Double crimp		2 x 1,5 mm ² 2 x 2,5 mm ² 2 x AWG 14-16									

Leicht aufsteckbar
Low insertion force

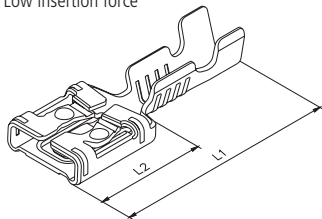

L

RSB 8238.158 F 6,3-1,5		0,5-<1,5	CuSn				19,0	7,4	0,8	DIN	8
	●	20-16	CuZn	●	●						
	●		Fe			●					
RSB 8238.258 F 6,3-2,5		>1-2,5	CuSn				19,0	7,4	0,8	DIN	8
	●	16-14	CuZn	●	●						
	●		Fe			●					

Leicht aufsteckbar
Low insertion force

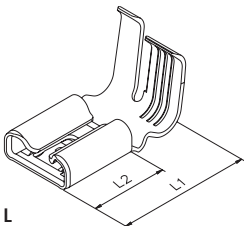

L

RSB 8240.158 F 6,3-1,5		0,5-1,5	CuSn	○	○		11,5	7,7	0,8	DIN	2
	●	20-16	CuZn	●	●						
	●		Fe			●					
RSB 8240.258 F 6,3-2,5		1,5-2,5	CuSn	○	○		11,5	7,7	0,8	DIN	1,8
	●	16-14	CuZn	●	●						
	●		Fe			●					
RSB 8240.1158 F 6,3-1,5 Für Gehäusemontage For housings		0,5-1,5	CuSn	○	○		11,5	7,7	0,8		2
	●	20-16	CuZn	●	●						
	●		Fe			●					
RSB 8240.1258 F 6,3-2,5 Für Gehäusemontage For housings		1,5-2,5	CuSn				11,5	7,7	0,8		1,8
	●	16-14	CuZn	○	○						
	●		Fe			●					

Leicht aufsteckbar
Low insertion force

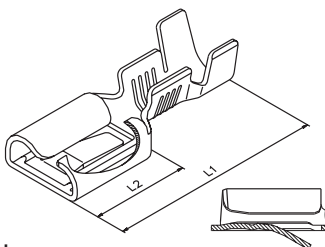

L

RSB 8220.1158 F 6,3-1,5 Für Gehäusemontage For housings		0,5-1,5	CuSn				17,15	7,7	0,8		8
	●	20-16	CuZn								
	●		Fe			●					

● Standard-Artikel / Standard parts ○ lieferbar auf Anfrage / available on request

■ Flachsteckhülsen für Steckbreite 6,3 mm

■ Receptacles for tab width 6,3 mm

Bauform Q = Quertransport L = Längstransport Supply condition Q = transverse transport / Side feed L = longitudinal transport / End feed	Artikel-Nummer Part number	Freigabe- s. Seiten 7/8 Approvals s. page 7/8	Leiter- quer- schnitt Wire size mm ² AWG	Material	Veredlung			Länge		Steck- dicke Tab thick- ness mm	Rast- posi- tion Inden- tation	Verp.-Einh. Bandform Packing unit Chain form x 1000
					blank	Sn	Ni					

Verriegelbar, leicht aufsteckbar
Self locking, low insertion force

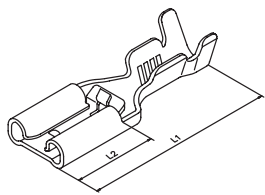

L

RSB 8178.108 F 6,3-1 Geeignet für RAST 5 Gehäuse Also for RAST 5 housings	●	0,5-<1	CuSn	○	○			19,2	7,7	0,8	DIN	8
	●	22-18	CuZn	●	●							
RSB 8178.258 F 6,3-2,5 Geeignet für RAST 5 Gehäuse Also for RAST 5 housings	●	1-<2,5	CuSn	○	○			19,2	7,7	0,8	DIN	6,5
	●	16-14	CuZn	●	●							
			CuNiZn	○								
RSB 8178.308 F 6,3-3 * Geeignet für RAST 5 Gehäuse Also for RAST 5 housings	●	2 x AWG	CuSn	○	○			19,2	7,7	0,8	DIN	4
	●	18-16	CuZn	●	●							
			CuNiZn	○								
RSB 8178.1108 Für Gehäuse mit externem Rasthaken For housing with external locking		0,34-<1	CuSn					19,2	7,7	0,8		8
		22-18	CuZn		●							
RSB 8178.1258 Für Gehäuse mit externem Rasthaken For housing with external locking		1-<2,5	CuSn	○				19,2	7,7	0,8		6,5
		16-14	CuZn		●							

Verriegelbar
Self locking

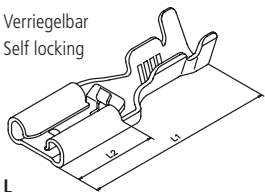

L

RSB 7960.020 F 6.3-1	●	0,5-1	CuSn	○	○			19,3	7,7	0,8	DIN	7
	●	20-18	CuZn	○	○							
	●		CuNiZn	○								
RSB 7961.020 F 6.3-2,5	●	1-2,5	CuSn	○	○			19,3	7,7	0,8	DIN	6
	●	16-14	CuZn	○	○							
	●		CuNiZn	○								

Verriegelbar
Self locking

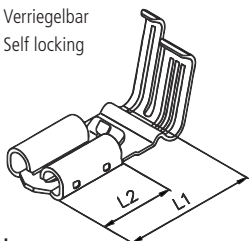

L

RSB 8126.010 F 6,3-1,5	●	0,5-1,5	CuSn	○	○			16,0	7,1	0,8	DIN	1,6
	●	20-16	CuZn	○	○							

Verriegelbar
Self locking

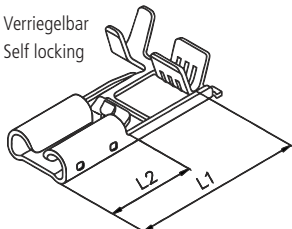

Q

RSB 8047 F 6,3-1		0,5-1	CuSn	○	○			18,5	7,7	0,8	DIN	4
	●	20-18	CuZn	○	○							
			CuNiZn	○								
RSB 8048 F 6,3-2,5		>1-2,5	CuSn	○	○			18,5	7,7	0,8	DIN	3,5
		16-14	CuZn	○	○							
			CuNiZn	○								

* Technisches Datenblatt über verarbeitbare Isolationsdurchmesser auf Anfrage.
Technical datasheet for available insulation diameters on request.

● Standard-Artikel / Standard parts ○ lieferbar auf Anfrage / available on request

FLACHSTECKER TABS

■ Flachstecker mit Steckbreite 2,8 mm

■ Tabs width 2,8 mm

Bauform Q = Quertransport L = Längstransport Supply condition Q = transverse transport / Side feed L = longitudinal transport / End feed	Artikel-Nummer Part number	DIN	Freigabens. Seiten 7/8 Approvals s. page 7/8	Leiterquerschnitt Wire size mm² AWG	Material	Veredlung			Länge		Steckbreite Tab width mm	Steckdicke Tab thickness mm	Rastposition Indentation	Verp.-Einh. Bandform Packing unit Chain form x 1000
						blank	Sn	Ni	L 1 mm	L 2 mm				
						un-plated	Sn	Ni						

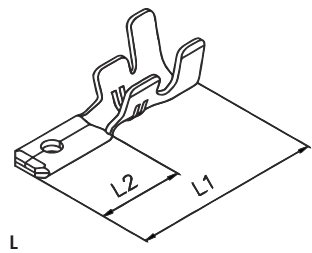

L

RMB 7958 F 2,8-1			0,5-1	CuSn				12,6	5,5	2,8	0,8	●	15
	●		20-18	CuZn	●	●							

Für Gehäuse
For housings

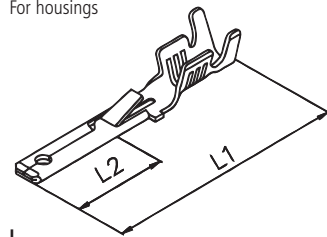

L

RMB 8039.001 Z 2,8-1			0,5-1,5	CuSn	○	○		22,5	8,0	2,8	0,8	DIN	8
			20-16	CuZn	●	●							
RMB 8039.003 Z 2,8-1			0,5-1,5	CuSn	○	○		22,5	8,0	2,8	0,8	ohne	8
			20-16	CuZn	●	●						without	

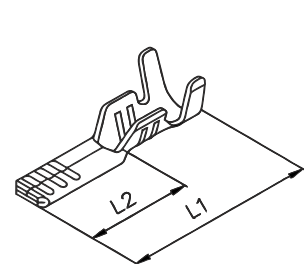

L

RMB 7930 V 2,8-1			0,5-1	CuSn				13,1	6,7	2,8	0,8	ohne	18
			20-18	CuZn	●	○						without	

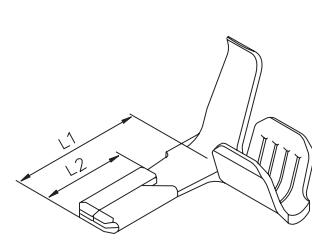

L

RMB 8205.1158 Z 2,8-1,5			0,75-2	CuZn		●		8,0	4,75	2,8	0,8	ohne	6
			18-14									without	

● Standard-Artikel / Standard parts ○ lieferbar auf Anfrage / available on request

■ Flachstecker mit Steckbreite 4,8 mm

■ Tabs width 4,8 mm

Bauform Q = Quertransport L = Längstransport Supply condition Q = transverse transport / Side feed L = longitudinal transport / End feed	Artikel-Nummer Part number	DIN	Freigabens. Seiten 7/8 Approvals s. page 7/8	Leiterquer-schnitt Wire size mm ² AWG	Material	Veredlung			Länge		Steckbreite Tab width mm	Steckdicke Tab thick-ness mm	Rastposi-tion Inden-tation	Verp.-Einh. Bandform Packing unit Chainform x 1000
						blank	Sn	Ni	L 1 mm	L 2 mm				
						un-plated	Sn	Ni						

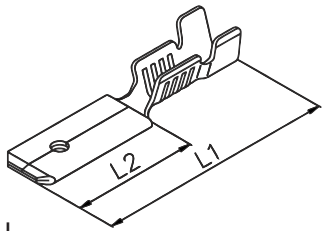

L

RMB 8165.108 Z 4,8-1			●	0,5-1,5 20-16	CuZn	●	●		21,7	11,4	4,8	0,8	●	8

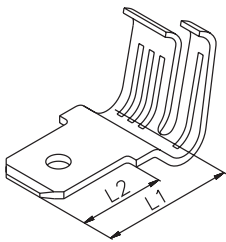

L

RMB 8043 Z 4,8-1				0,5-1 20-18	CuZn	●			10,2	6,3	4,8	0,5	●	4
					Fe			●						

● Standard-Artikel / Standard parts ○ lieferbar auf Anfrage / available on request

FLACHSTECKER TABS

■ Flachstecker mit Steckbreite 6,3 mm

■ Tabs width 6,3 mm

Bauform Q = Quertransport L = Längstransport Supply condition Q = transverse transport / Side feed L = longitudinal transport / End feed	Artikel-Nummer Part number	DIN	Frei- gaben s. Seiten 7/8 Appro- vals s. page 7/8 AWG	Leiter- quer- schnitt Wire size mm ²	Material	Veredlung			Länge		Steck- breite Tab width mm	Steck- dicke Tab thick- ness mm	Rast- posi- tion Inden- tation	Verp.-Einh.	
						blank	Sn	Ni	L 1 mm	L 2 mm				Band- form	lose piece
						un- plated	Sn	Ni							
														x 1000	

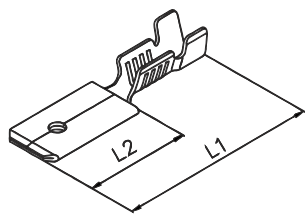

L

RMB 7840 Z 6,3-1				0,5-1,5	CuSn				21,7	11,4	6,3	0,8	DIN	8	
				20-16	CuZn	●	●								
RMB 7841 Z 6,3-2,5				>1-2,5	CuSn				21,7	11,4	6,3	0,8	DIN	6	
				16-14	CuZn	●	●								

Für Gehäuse
For housings

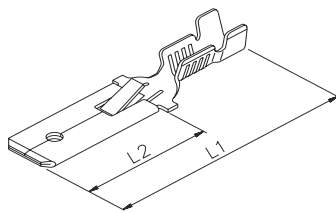

L

RMB 7831.010 Z 6,3-1	46343 T 3			0,5-1,5	CuSn	●	●		28,0	15,5	6,3	0,8	DIN	5,5	
	B 6,3-1		●	20-16	CuZn	●	●								
RMB 7831.011 Z 6,3-1	46343 T 3			0,5-1,5	CuSn	●	○		28,0	15,5	6,3	0,8	ohne with- out	5,5	
	A 6,3-1		●	20-16	CuZn	●	●								
RMB 7833.010 Z 6,3-2,5	46343 T 3			1-2,5	CuSn	●	●		28,0	15,5	6,3	0,8	DIN	4,5	
	B 6,3-2,5		●	16-14	CuZn	●	●								
RMB 7833.011 Z 6,3-2,5	46343 T 3			1-2,5	CuSn	●	●		28,0	15,5	6,3	0,8	ohne with- out	4,5	
	A 6,3-2,5		●	16-14	CuZn	●	●								

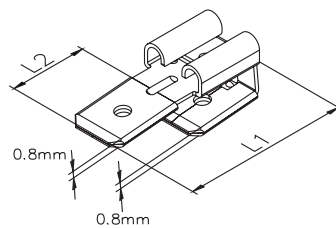

RM 5889 x 6,3					CuSn				18,3	8,0	6,3	0,8	●		5
					CuZn	○	○								

● Standard-Artikel / Standard parts ○ lieferbar auf Anfrage / available on request

■ Crimpkontakte für Leiterplatten

■ Crimp contacts for printed boards

Bauform Q = Quertransport L = Längstransport Supply condition Q = transverse transport / Side feed L = longitudinal transport / End feed	Artikel-Nummer	Leiter- quer- schnitt	Material	Veredlung			Abmessungen			Material- stärke	Verp.-Einh. Bandform
	Part number	Wire size	Material	Finishing			Dimensions			Material thickness	Packing unit Chain form
				blank	Sn	Ni	B 1 mm	L 1 mm	L 2 mm		
		mm ² AWG		un- plated	Sn	Ni					

Board-in

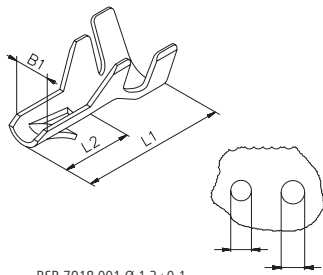

RSB 7918.001 Ø 1.3+0.1

RSB 7918.002 Ø 1.85+0.1

Q

RSB 7918.001 V 1,2-0,35	0,12-0,35 26-22	CuZn		●		1,22	6,6	2,75	0,2	12
RSB 7918.002 V 1,6-0,8	0,32-1 22-18	CuZn		●		1,63	6,6	2,75	0,2	8

● Standard-Artikel / Standard parts ○ lieferbar auf Anfrage / available on request

LEITERPLATTEN-KONTAKTE PRINTED BOARDS CONTACTS

- Flachstecker für Leiterplatten,
Steckbreite 2,8 mm

- Tabs for printed circuits,
width 2,8 mm

Bauform Q = Quertransport L = Längstransport Supply condition Q = transverse transport / Side feed L = longitudinal transport / End feed	Artikel-Nummer Part number	Material	Veredlung			Länge			Steck- dicke Tab thick- ness mm	Steck- breite Tab width mm	Rast- loch Inden- tation	Verp.-Einh.	
			blank	Sn	Ni	L 1 mm	L 2 mm	L 3 mm				Band- form	lose piece
			Finishing										
			un- plated	Sn	Ni								
												x 1000	

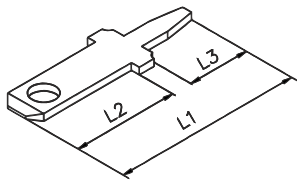

Q

RMB 5920.003 P 1,4-2,8	CuSn				13,2	7,5	4,1	0,5	2,8	●	20	40
	CuZn	○	○									
	Fe											
RMB 5920.004 P 1,4-2,8	CuSn				13,2	7,5	4,1	0,8	2,8	●	20	40
	CuZn	●	●									
	Fe											

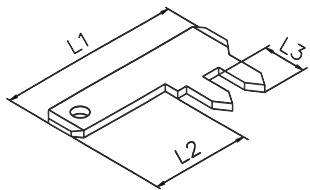

Q

RMB 6199	CuSn				12,5	min. 7	3	0,5	2,8	●	12	
	CuZn	○	●									
	Fe											

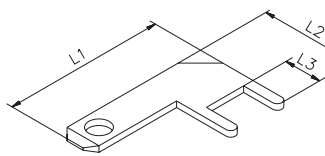

RM 6044.001 P 1,2 - 2,8	CuSn				13,5	8,0	3	0,5	2,8	DIN		10
	CuZn	○	○									
	Fe											

● Standard-Artikel / Standard parts ○ lieferbar auf Anfrage / available on request

- Flachstecker für Leiterplatten,
Steckbreite 4,8 mm

- Tabs for printed circuits,
width 4,8 mm

Bauform Q = Quertransport L = Längstransport Supply condition Q = transverse transport / Side feed L = longitudinal transport / End feed	Artikel-Nummer Part number	Material	Veredlung			Länge			Steck- dicke Tab thick- ness mm	Steck- breite Tab width mm	Rast- loch Inden- tation	Verp.-Einh.	
			blank	Sn	Ni	L 1 mm	L 2 mm	L 3 mm				Band- form	lose piece
			Finishing										
			un- plated	Sn	Ni								
												x 1000	

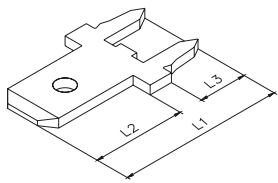

Q

RMB 6008 P 1,3-4,8	CuSn				14,0	8,0	4,0	0,8	4,8	●	15	20
	CuZn	○	●									
RMB 6008.001 P 1,3-4,8	CuSn				14,0	8,0	4,0	0,5	4,8	●	15	20
	CuZn	○	○									
RMB 6008.002 P 1,3-4,8	CuSn	○	○		14,0	8,0	4,0	0,8	4,8	DIN	15	20
	CuZn	○	○									
RMB 6008.003 P 1,3-4,8	CuSn				14,0	8,0	4,0	0,5	4,8	●	15	20
	CuZn	○	○									

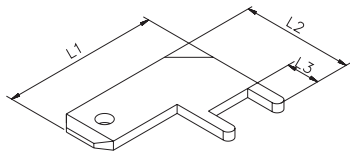

RM 6045 P 1,2-4,8	CuSn				13,5	10,0	3,0	0,8	4,8	●		15
	CuZn		○									

● Standard-Artikel / Standard parts ○ lieferbar auf Anfrage / available on request

LEITERPLATTEN-KONTAKTE PRINTED BOARDS CONTACTS

- Flachstecker für Leiterplatten,
Steckbreite 6,3 mm

- Tabs for printed circuits,
width 6,3 mm

Bauform Q = Quertransport L = Längstransport Supply condition Q = transverse transport / Side feed L = longitudinal transport / End feed	Artikel-Nummer Part number	Material	Veredlung			Abmessungen			Steck- dicke	Steck- breite	Rastloch	Verp.-Einh.	
			blank	Sn	Ni	L 1 mm	L 2 mm	L 3 mm				Chain- form	loose piece
			Finishing										
			un- plated	Sn	Ni								
												x 1000	

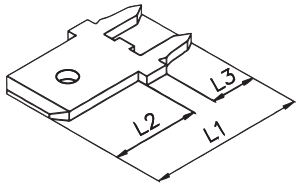

Q

RMB 6006 P 1,3-6,3	CuSn				14,0	8,0	4,0	0,8	6,3	DIN	15	20
	CuZn	●	●									
	Fe											
RMB 6006.002 P 1,3-6,3 Für Gehäuse For housings	CuSn				16,0	10,0	4,0	0,8	6,3	DIN	15	20
	CuZn		●									
	Fe											
RMB 6006.100 P 1,3-6,3	CuZn		●		14,0	8,0	4,0	0,8	6,3	DIN	15	
			selectiv selective									

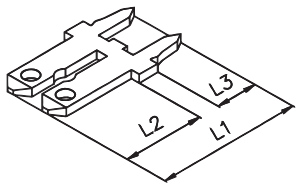

Q

RMB 6007.002 P 1,3-6,3	CuSn				14,0	8,0	4,0	0,8	6,3	DIN	15	20
	CuZn	○	○									
	Fe											

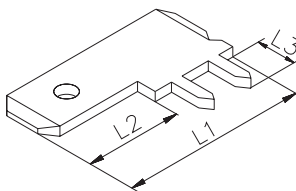

Q

RMB 6201 P 1,2-6,3	CuSn				18,0	8,0	4,0	0,8	6,3	DIN	10	10
	CuZn	○	●									
	Fe											

● Standard-Artikel / Standard parts ○ lieferbar auf Anfrage / available on request

- Flachstecker zum Anschweißen,
Steckbreite 6,3 mm

- Weld tabs
width 6,3 mm

Bauform Q = Quertransport L = Längstransport Supply condition Q = transverse transport / Side feed L = longitudinal transport / End feed	Artikel-Nummer Part number	Material	Veredlung			Abmessungen			Steck- dicke Tab thick- ness mm	Win- kel Angle °	Rastloch Inden- tation	Verp.-Einh.	
			blank	Sn	Ni	L 1 mm	L 2 mm	L 3 mm				Band- form	lose piece
			Finishing										
			un- plated	Sn	Ni	Chain form	loose piece						
												x 1000	

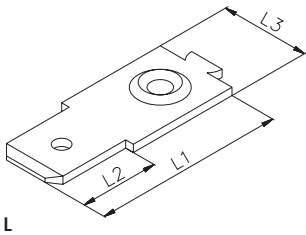

L

RMB 7942 VS-6,3	CuZn				19,0	8,0	8,0	0,8	0°	DIN	9	
	Fe			●								

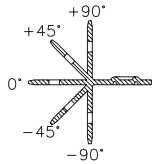
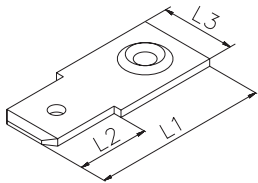

RM 6015 VS 6,3	CuZn				19,0	8,0	8,0	0,8	0°	DIN		13
	Fe			○								
RM 6015.645 VS 6,3	CuZn					8,0	8,0	0,8	+45°	DIN		13
	Fe			○								
RM 6015.845 VS 6,3	CuZn					8,0	8,0	0,8	-45°	DIN		13
	Fe			○								
RM 6015.290 VS 6,3	CuZn					8,0	8,0	0,8	+90°	DIN		13
	Fe			○								
RM 6015.690 VS 6,3	CuZn					8,0	8,0	0,8	-90°	DIN		13
	Fe			○								

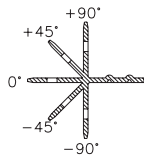
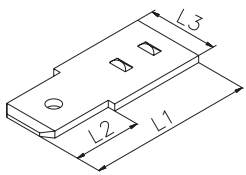

RM 6015.001 VS 6,3	CuZn				19,0	8,0	8,0	0,8	0°	DIN		13
	Fe			○								
RM 6015.345 VS 6,3	CuZn					8,0	8,0	0,8	+45°	DIN		13
	Fe			○								
RM 6015.245 VS 6,3	CuZn					8,0	8,0	0,8	-45°	DIN		13
	Fe			○								
RM 6015.890 VS 6,3	CuZn					8,0	8,0	0,8	+90°	DIN		13
	Fe			○								
RM 6015.490 VS 6,3	CuZn					8,0	8,0	0,8	-90°	DIN		13
	Fe			○								

- Standard-Artikel / Standard parts
- lieferbar auf Anfrage / available on request

FLACHSTECKER TABS

- Flachstecker zum Anschweißen,
Steckbreite 6,3 mm

- Weld tabs
width 6,3 mm

Bauform Q = Quertransport L = Längstransport Supply condition Q = transverse transport / Side feed L = longitudinal transport / End feed	Artikel-Nummer Part number	Material	Veredlung			Abmessungen			Steck- dicke Tab thick- ness mm	Winkel Angle °	Rastloch Inden- tation	Verp.-Einh. lose Packing unit loose piece x 1000
			blank	Sn	Ni	L 1 mm	L 2 mm	L 3 mm				
			Finishing									
			un- plated									

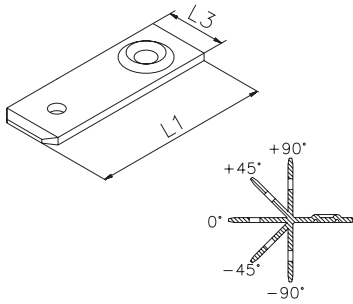

RM 6015.003 VS 6,3	CuSn				19,0		6,3	0,8	0°	DIN	13
	CuZn										
	Fe			○							
RM 6015.545 VS 6,3	CuSn						6,3	0,8	+45°	DIN	13
	CuZn										
	Fe			○							
RM 6015.745 VS 6,3	CuSn						6,3	0,8	-45°	DIN	13
	CuZn										
	Fe			○							
RM 6015.190 VS 6,3	CuSn						6,3	0,8	+90°	DIN	13
	CuZn										
	Fe			○							
RM 6015.390 VS 6,3	CuSn						6,3	0,8	-90°	DIN	13
	CuZn										
	Fe			○							

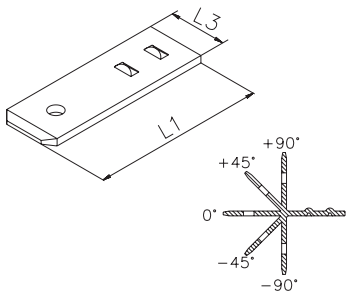

RM 6015.002 VS 6,3	CuSn				19,0		6,3	0,8	0°	DIN	13
	CuZn										
	Fe			○							
RM 6015.445 VS 6,3	CuSn						6,3	0,8	+45°	DIN	13
	CuZn										
	Fe			○							
RM 6015.145 VS 6,3	CuSn						6,3	0,8	-45°	DIN	13
	CuZn										
	Fe			○							
RM 6015.790 VS 6,3	CuSn						6,3	0,8	+90°	DIN	13
	CuZn										
	Fe			○							
RM 6015.590 VS 6,3	CuSn						6,3	0,8	-90°	DIN	13
	CuZn										
	Fe			○							

● Standard-Artikel / Standard parts ○ lieferbar auf Anfrage / available on request

- Flachstecker zum Befestigen und Anschweißen,
Steckbreite 4,8 mm

- Tabs for fixing and welding,
width 4,8 mm

Bauform Q = Quertransport L = Längstransport	Artikel-Nummer	Material	Veredlung			Abmessungen			Bohrungs Ø	Steck- dicke	Win- kel	Rast- loch	Verp.-Einh. lose
			blank	Sn	Ni	L 1 mm	L 2 mm	L 3 mm					
			Finishing										
Supply condition Q = transverse transport / Side feed L = longitudinal transport / End feed	Part number	Material	un- plated	Sn	Ni	Dimensions			Drill hole Ø	Tab thick- ness	Angle	Inden- tation	Packing unit loose piece
									D 1 mm	mm	°		x 1000

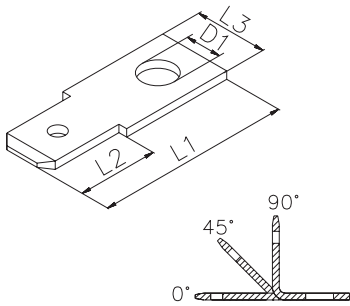

RM 6080 A 3-4,8	CuZn Fe	○	○		17,5	7,2	6,5	3,2	0,8	0°	DIN	20
RM 6080 A 4-4,8	CuZn Fe	○	○		17,5	7,2	6,5	4,3	0,8	0°	DIN	20
RM 6080.045 A 3-4,8	CuZn Fe	○	○		7,2	6,5	3,2	0,8	0,8	45°	DIN	20
RM 6080.045 A 4-4,8	CuZn Fe	○	○		7,2	6,5	4,3	0,8	0,8	45°	DIN	20
RM 6080.090 A 2,2-4,8	CuZn Fe	○	○		7,2	6,5	2,2	0,8	0,8	45°	DIN	20
RM 6080.090 A 3-4,8	CuZn Fe	○	○		7,2	6,5	3,2	0,8	0,8	90°	DIN	20
RM 6080.090 A 4-4,8	CuZn Fe	○	○		7,2	6,5	4,3	0,8	0,8	90°	DIN	20

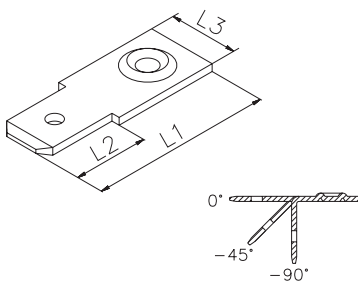

RM 6059 VS 4,8	Fe			○	17,0	7,4	6,5		0,8	0°		20
RM 6059.645 VS 4,8	Fe			○	7,4	6,5		0,8		-45°		20
RM 6059.690 VS 4,8	Fe			○	7,4	6,5		0,8		-90°		20

● Standard-Artikel / Standard parts ○ lieferbar auf Anfrage / available on request

FLACHSTECKER TABS

- Flachstecker zum Befestigen,
Steckbreite 6,3 mm

- Tabs for fixing,
width 6,3 mm

Bauform Q = Quertransport L = Längstransport Supply condition Q = transverse transport / Side feed L = longitudinal transport / End feed	Artikel-Nummer Part number	Material	Veredlung			Abmessungen			Bohrungs- Ø	Steck- dicke	Win- kel	Rast- loch	Verp.-Einh. lose
			blank	Sn	Ni	Dimensions							
			un- plated	Sn	Ni	L 1 mm	L 2 mm	L 3 mm					
													x 1000

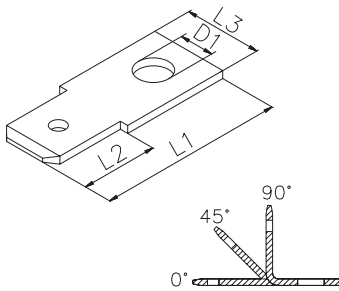

RM 6015 A 3-6,3	CuZn	○	●		19,0	8,1	8,0	3,2	0,8	0°	DIN	13
	Fe			○								
RM 6015 A 4-6,3	CuZn	○	●		19,0	8,1	8,0	4,3	0,8	0°	DIN	13
	Fe			○								
RM 6015 A 5-6,3	CuZn	○	○		19,0	8,1	8,0	5,3	0,8	0°	DIN	13
	Fe			○								
RM 6015.045 A 3-6,3	CuZn	○	○		8,1	8,0	8,0	3,2	0,8	45°	DIN	13
	Fe			○								
RM 6015.045 A 4-6,3	CuZn	●	○		8,1	8,0	8,0	4,3	0,8	45°	DIN	13
	Fe			●								
RM 6015.045 A 5-6,3	CuZn	●	●		8,1	8,0	8,0	5,3	0,8	45°	DIN	13
	Fe			○								
RM 6015.045 A 6-6,3	CuZn	●	●		8,1	8,0	8,0	6,3	0,8	45°	DIN	13
	Fe			○								
RM 6015.090 A 3-6,3	CuZn	○	○		8,1	8,0	8,0	3,2	0,8	90°	DIN	13
	Fe			○								
RM 6015.090 A 3,5-6,3	CuZn	○	○		8,1	8,0	8,0	3,7	0,8	90°	DIN	13
	Fe			○								
RM 6015.090 A 4-6,3	CuZn	○	○		8,1	8,0	8,0	4,3	0,8	90°	DIN	13
	Fe			○								
RM 6015.090 A 5-6,3	CuZn	○	○		8,1	8,0	8,0	5,3	0,8	90°	DIN	13
	Fe											

● Standard-Artikel / Standard parts ○ lieferbar auf Anfrage / available on request

- Flachstecker zum Befestigen,
Steckbreite 6,3 mm

- Tabs for fixing,
width 6,3 mm

Bauform Q = Quertransport L = Längstransport	Artikel-Nummer	Material	Veredlung			Abmessungen			Bohrungs- Ø	Steck- dicke	Win- kel	Rast- loch	Verp.-Einh. lose
			blank	Sn	Ni	Dimensions							
			un- plated			L 1 mm	L 2 mm	L 3 mm					
Supply condition Q = transverse transport / Side feed L = longitudinal transport / End feed	Part number	Material											x 1000

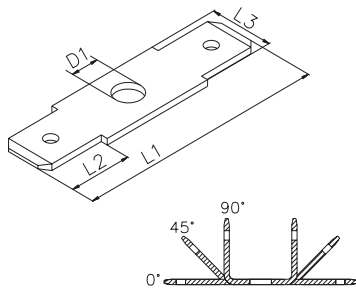

RM 6129 DSL 3-6,3	CuZn Fe	○	○			30	8,1	8,0	3,1	0,8	0°	DIN	10
RM 6129 A 4-6,3	CuZn Fe	○	○			30	8,1	8,0	4,3	0,8	0°	DIN	10
RM 6129 A 5-6,3	CuZn Fe	○	○			30	8,1	8,0	5,3	0,8	0°	DIN	10
RM 6129.045 DSL 3-6,3	CuZn Fe	○	○				8,1	8,0	3,1	0,8	45°	DIN	8
RM 6129.045 A 4-6,3	CuZn Fe	○	○				8,1	8,0	4,3	0,8	45°	DIN	8
RM 6129.045 A 5-6,3	CuZn Fe	○	○				8,1	8,0	5,3	0,8	45°	DIN	8
RM 6129.090 DSL 3-6,3	CuZn Fe	○	○				8,1	8,0	3,1	0,8	90°	DIN	6
RM 6129.090 A 4-6,3	CuZn Fe	○	○				8,1	8,0	4,3	0,8	90°	DIN	6
RM 6129.090 A 5-6,3	CuZn Fe	○	○				8,1	8,0	5,3	0,8	90°	DIN	6

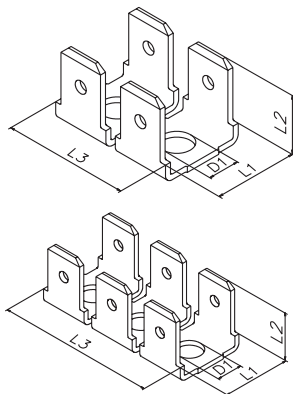

RM 6129/2 A 4-6,3	CuZn	○	○			11,6	8,1	17,5	4,3	0,8	0°	DIN	5
RM 6129.075/2 A 4-6,3	CuZn	○	○				8,1	17,5	4,3	0,8	75°	DIN	2
RM 6129.090/2 A 4-6,3	CuZn	○	○				8,1	17,5	4,3	0,8	90°	DIN	2
RM 6129.045/3 DSL 3-6,3	CuZn	○	○				8,1	27,0	3,0	0,8	45°	DIN	1,3
RM 6129.090/3 A 4-6,3	CuZn	○	○				8,1	27,0	4,3	0,8	90°	DIN	1,3

- Standard-Artikel / Standard parts ○ lieferbar auf Anfrage / available on request

KRALLENKABELSCHUHE OPEN BARREL TERMINALS

■ Krallenkabelschuhe ohne Isolationscrimp

■ Open barrel terminals without insulation crimp

Bauform Q = Quertransport L = Längstransport Supply condition Q = transverse transport / Side feed L = longitudinal transport / End feed	Artikel-Nummer	Leiter- quer- schnitt	Material	Veredlung			Außen Ø	Bohrungs- Ø	Länge	Material- stärke	Verp.-Einh. Bandform
	Part number	Wire size	Material	Finishing			Outside Ø	Drill hole Ø	Length	Material thickness	Packing unit Chain form
				un- plated	Sn	Ni					
		mm ² AWG					d 3 mm	d 2 mm	L mm	mm	x 1000

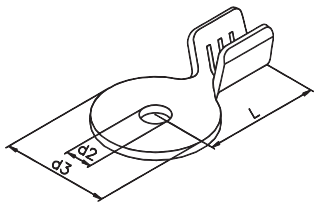

L

RSB 7727 A 1,7-1	0,5-1	CuSn				6,8	1,70	7,5	0,5	20
	20-18	CuZn	○	●						
		Fe			○					
RSB 7727 A 2,6-1	0,5-1	CuSn				6,8	2,80	7,5	0,5	20
	20-18	CuZn	○	○						
		Fe			○					
RSB 7727 A 3-1	0,5-1	CuSn				6,8	3,20	7,5	0,5	20
	20-18	CuZn	○	○						
		Fe			○					
RSB 7727 A 3,5-1	0,5-1	CuSn				6,8	3,70	7,5	0,5	20
	20-18	CuZn	○	○						
		Fe			○					
RSB 7727 A 4-1	0,5-1	CuSn				6,8	4,30	7,5	0,5	20
	20-18	CuZn	●	●						
		Fe			○					

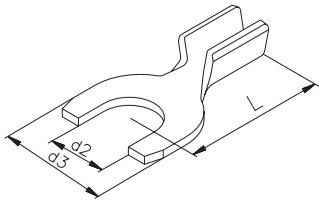

L

RSB 7779 C 5-6	>3-5	CuSn				9,5	5,50	15,5	0,8	4,5
	12-10	CuZn	●	○						
		Fe								
RSB 7779 C 5-10	>5-10	CuSn				9,3	5,50	15,5	1,0	2
	10-7	CuZn	●	○						
		Fe								
RSB 7779 C 6-10	>5-10	CuSn				9,3	6,20	15,5	1,0	2
	10-7	CuZn	●	○						
		Fe								

● Standard-Artikel / Standard parts ○ lieferbar auf Anfrage / available on request

■ Krallenkabelschuhe mit Isolationscrimp

■ Open barrel terminals with insulation crimp

Bauform Q = Quertransport L = Längstransport Supply condition Q = transverse transport / Side feed L = longitudinal transport / End feed	Artikel-Nummer	DIN	UL-Freigaben s. Seiten 7/8	Leiterquerschnitt	Material	Veredlung			Außen Ø	Bohrungs- Ø	Länge	Material- stärke	Verp.-Einh. Bandform
	Part number	Approvals s. page 7/8	Wire size	Material		blank	Sn	Ni					
					un-plated	Sn	Ni	Outside Ø	Drill hole Ø	Length	Material thickness	Packing unit Chain form	
				mm ² AWG					d 3 mm	d 2 mm	L mm	mm	x 1000

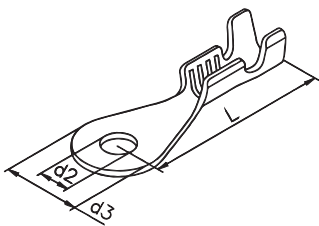

L

RSB 7813 A 3-0,5				0,14-0,5 26-20	CuSn				5,0	3,2	8,5	0,3	22
					CuZn	○	●						
					Fe								
RSB 7716.001 A 3-1				0,5-1 20-18	CuSn				6,3	3,2	8,8	0,5	14
					CuZn	●	●						
					Fe			○					
RSB 7716.001 A 3,5-1				0,5-1 20-18	CuSn				6,3	3,7	8,8	0,5	14
					CuZn	●	●						
					Fe			○					
RSB 7716.001 A 4-1				0,5-1 20-18	CuSn				6,3	4,3	8,8	0,5	14
					CuZn	●	●						
					Fe			○					
RSB 7206 A 3-1	46225			>0,25-1 22-18	CuSn	○	○		8,0	3,2	18,0	0,6	6
	A 3-1		●		CuZn	○	●						
					Fe			○					
RSB 7206 A 3,5-1				>0,25-1 22-18	CuSn	○	○		8,0	3,7	18,0	0,6	6
					CuZn	○	○						
					Fe			○					
RSB 7206 A 4-1	46225			>0,25-1 22-18	CuSn	○	○		8,0	4,3	18,0	0,6	6
	A 4-1		●		CuZn	●	●						
					Fe			○					
RSB 7207 A 5-1	46225			0,25-1 24-18	CuSn	○	○		9,5	5,3	17,0	0,6	6
	A 5-1				CuZn	●	●						
					Fe			○					
RSB 8202 A 6-1	46225			0,5-1 20-18	CuSn	○	●		12,0	6,5	22,0	0,6	6
	A 6-1				CuZn	○	○						
					Fe								
RSB 7881 A 3-1,5				0,5-1,5 18-16	CuSn				8,8	3,2	12,7	0,5	6
					CuZn	○	○						
					Fe								
RSB 7881 A 3,5-1,5				0,5-1,5 18-16	CuSn				8,8	3,7	12,7	0,5	6
					CuZn	●	○						
					Fe								
RSB 7881 A 4-1,5				0,5-1,5 18-16	CuSn				8,8	4,3	12,7	0,5	6
					CuZn	●	○						
					Fe								
RSB 7881 A 5-1,5				0,5-1,5 18-16	CuSn				8,8	5,3	12,7	0,5	6
					CuZn	○	○						
					Fe								
RSB 7881 A 6-1,5				0,5-1,5 18-16	CuSn				8,8	6,5	12,7	0,5	6
					CuZn	●	●						
					Fe								

● Standard-Artikel / Standard parts ○ lieferbar auf Anfrage / available on request

KRALLENKABELSCHUHE OPEN BARREL TERMINALS

■ Krallenkabelschuhe mit Isolationscrimp

■ Open barrel terminals with insulation crimp

Bauform Q = Quertransport L = Längstransport Supply condition Q = transverse transport / Side feed L = longitudinal transport / End feed	Artikel-Nummer Part number	DIN UL	Leiterquer- schnitt Wire size mm ² AWG	Material	Veredlung			Außen Ø	Bohrungs- Ø	Länge	Material- stärke	Verp.-Einh. Bandform
					blank	Sn	Ni					
					un- plated	Sn	Ni					
								Outside Ø	Drill hole Ø	Length L mm	Material thickness mm	Packing unit Chain form x 1000

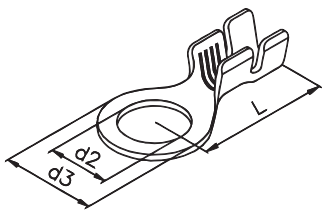

L

* ähnlich / similar to DIN 46225 A 6-2,5

** ähnlich / similar to DIN 46225 A 8-2,5

RSB 8203 A 6-2,5	*	1-2,5 16-14	CuSn	○	●		12,0	6,5	22,0	0,6	5,5
			CuZn	○	○						
RSB 8204 A 8-2,5	**	1-2,5 16-14	CuSn	○	●		14,0	8,4	21,0	0,6	4,8
			CuZn								
RSB 7208 A 3-2,5	46225 A 3-2,5	> 1-3 16-14	CuSn	○	○		8,0	3,2	18,0	0,6	5
			CuZn	○	○						
			Fe			○					
RSB 7208 A 4-2,5	46225 A 4-2,5	> 1-3 16-14	CuSn	○	○		8,0	4,3	18,0	0,6	5
			CuZn	●	●						
			Fe			●					
RSB 7209 A 5-2,5	46225 A 5-2,5	> 1-3 16-14	CuSn	○	○		9,5	5,3	17,0	0,6	5
			CuZn	●	●						
			Fe			○					
RSB 7209 A 6-2,5		> 1-3 16-14	CuSn	○	○		9,5	6,5	17,0	0,6	5
			CuZn	○	●						
			Fe			○					
RSB 7877 A 3-4		1-2,5 16-14	CuSn				8,7	3,2	15,4	0,8	5
			CuZn	○	○						
			Fe								
RSB 7877 A 3,5-4		1-2,5 16-14	CuSn				8,7	3,7	15,4	0,8	5
			CuZn	○	○						
			Fe								
RSB 7877 A 4-4		1-2,5 16-14	CuSn				8,7	4,3	15,4	0,8	5
			CuZn	●	●						
			Fe								
RSB 7877 A 5-4		1-2,5 16-14	CuSn				8,7	5,3	15,4	0,8	5
			CuZn	○	○						
			Fe								
RSB 7788 A 4-6	● ●	>2,5-6 12-10	CuSn	○	○		11,8	4,3	20,0	0,8	3
			CuZn	○	●						
			Fe								
RSB 7788 A 5-6	● ●	>2,5-6 12-10	CuSn	○	○		11,8	5,3	20,0	0,8	3
			CuZn	○	●						
			Fe								
RSB 7788 A 6-6	● ●	>2,5-6 12-10	CuSn	○	○		11,8	6,4	20,0	0,8	3
			CuZn	○	●						
			Fe								
RSB 7788 A 8-6	● ●	>2,5-6 12-10	CuSn	○	○		11,8	8,4	20,0	0,8	3
			CuZn	○	●						
			Fe								
RSB 8201 A 6-6	46225 A 6-6	2,5-6 12-10	CuSn	○	●		12,0	6,5	25,0	0,8	3
			CuZn	○	○						
RSB 8200 A 6-10	46225 A 6-10	6-10 10-8	CuSn	○	●		12,0	6,5	23,0	1,0	2
			CuZn	○	○						

● Standard-Artikel / Standard parts ○ lieferbar auf Anfrage / available on request

- Krallenkabelschuhe mit Isolationscrimp
- Krallenkabelschuhe Sonderausführungen
- Open barrel terminals with insulation crimp
- Open barrel terminals special types

Bauform Q = Quertransport L = Längstransport	Artikel-Nummer	DIN UL	Leiterquer- schnitt	Material	Veredlung			Außen Ø	Bohrungs- Ø	Länge	Material- stärke	Verp.-Einh. Bandform
					blank	Sn	Ni					
					Finishing							
Supply condition Q = transverse transport / Side feed L = longitudinal transport / End feed	Part number		Wire size	Material	un- plated	Sn	Ni	d 3 mm	d 2 mm	L mm	mm	x 1000

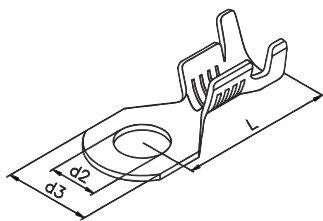

RSB 7716.002 A 2,7-1	0,5-1 20-18	CuSn				4,5	2,7	8,8	0,5	16
		CuZn	○	○						
		Fe			○					
RSB 7881.001 A 3-1,5	0,5-1,5 18-16	CuSn				7,8	3,2	12,7	0,5	6
		CuZn	○	○						
		Fe								
RSB 7881.001 A 3,5-1,5	0,5-1,5 18-16	CuSn				7,8	3,7	12,7	0,5	6
		CuZn	○	○						
		Fe								
RSB 7881.001 A 4-1,5	0,5-1,5 18-16	CuSn				7,8	4,3	12,7	0,5	6
		CuZn	●	●						
		Fe								
RSB 7788.001 A 4-6	>2,5-6 12-10	CuSn				9,0	4,3	20,0	0,8	3
		CuZn	○	○						
		Fe								
RSB 7788.001 A 5-6	>2,5-6 12-10	CuSn				9,0	5,3	20,0	0,8	3
		CuZn	○	●						
		Fe								
RSB 7788.001 A 6-6	>2,5-6 12-10	CuSn				9,0	6,4	20,0	0,8	3
		CuZn	○	○						
		Fe								

L

Sonderausführungen
Special types

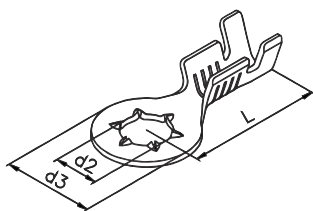

RSB 8134.010 V 4-1,5	0,5-1,5 20-16	CuSn				8,8	4,3	12,7	0,5	6
		CuZn								
		Fe		●	○					
RSB 7923.002 V 3,5-1	● 0,34-1 ● 22-18	CuSn	○	○		8,8	3,8	15,5	0,6	7
		CuZn	○	○						
		Fe			○					
RSB 7923.002 V 5-1	● 0,34-1 ● 22-18	CuSn	○	○		8,8	5,2	15,5	0,6	7
		CuZn	○	○						
		Fe			●					

L

● Standard-Artikel / Standard parts ○ lieferbar auf Anfrage / available on request

KRALLENKABELSCHUHE OPEN BARREL TERMINALS

■ Krallenkabelschuhe C-Form

■ Open barrel terminals C-Type

Bauform Q = Quertransport L = Längstransport Supply condition Q = transverse transport / Side feed L = longitudinal transport / End feed	Artikel-Nummer Part number	DIN	Leiterquer- schnitt Wire size mm ² AWG	Material	Veredlung			Außen Ø Outside Ø d 3 mm	Bohrungs- Ø Drill hole Ø d 2 mm	Länge Length L mm	Material- stärke Material thickness mm	Verp.-Einh. Bandform Packing unit Chain form x 1000
					blank	Sn	Ni					
					un- plated	Sn	Ni					

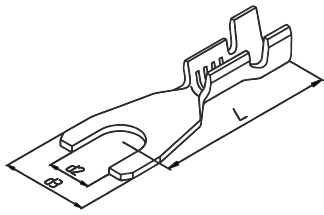

L

RSB 7738 C 3-1	0,5-1 20-18	CuSn				5,9	3,20	9,0	0,5	12	
		CuZn	●	●							
		Fe									
RSB 7830 C 3-1	0,5-1 20-18	CuSn				8,0	3,20	18,0	0,6	5	
		CuZn	○	○							
		Fe									
RSB 7830.001 C 3-1	0,5-1 20-18	CuSn				6,8	3,20	18,0	0,6	5	
		CuZn	○	○							
		Fe									
RSB 7830.001 C 3,5-1	0,5-1 20-18	CuSn				6,8	3,70	18,0	0,6	5	
		CuZn	○	●							
		Fe									
RSB 7830 C 4-1	0,5-1 20-18	CuSn				8,0	4,30	18,0	0,6	5	
		CuZn	●	○							
		Fe									
RSB 7830.001 C 4-1	0,5-1 20-18	CuSn				6,8	4,30	18,0	0,6	5	
		CuZn	○	○							
		Fe									
RSB 7830 C 5-1	0,5-1 20-18	CuSn				8,0	5,30	17,5	0,6	5	
		CuZn	○	○							
		Fe									
RSB 7843 C 3-2,5	>1-2,5 16-14	CuSn				8,0	3,20	18,0	0,6	5	
		CuZn	○	○							
		Fe									
RSB 7843.001 C 3-2,5	>1-2,5 16-14	CuSn				6,8	3,20	18,0	0,6	5	
		CuZn	○	○							
		Fe									
RSB 7843 C 3,5-2,5	>1-2,5 16-14	CuSn				8,0	3,70	18,0	0,6	5	
		CuZn	○	○							
		Fe									
RSB 7843.001 C 3,5-2,5	>1-2,5 16-14	CuSn				6,8	3,70	18,0	0,6	5	
		CuZn	○	○							
		Fe									
RSB 7843.001 C 4-2,5	>1-2,5 16-14	CuSn				6,8	4,30	18,0	0,6	5	
		CuZn	○	●							
		Fe									
RSB 7843 C 4-2,5	46225 B 4-2,5	>1-2,5	CuSn			8,0	4,30	18,0	0,6	5	
		16-14	CuZn	●	●						
		Fe									
RSB 7843 C 5-2,5	>1-2,5 16-14	CuSn				8,0	5,30	17,5	0,6	5	
		CuZn	●	○							
		Fe									

● Standard-Artikel / Standard parts ○ lieferbar auf Anfrage / available on request

Bauform Q = Quertransport L = Längstransport Supply condition Q = transverse transport / Side feed L = longitudinal transport / End feed	Artikel-Nummer	Freigaben s. Seite 7/8	Leiterquer- schnitt	Material	Veredlung			Länge	Material- stärke	Verp.-Einh. Bandform
	Part number	Approvals s. page 7/8	Wire size mm ² AWG	Material	Finishing			Length L 2 mm	Material thickness mm	Packing unit Chain form x 1000
					blank	Sn	Ni			

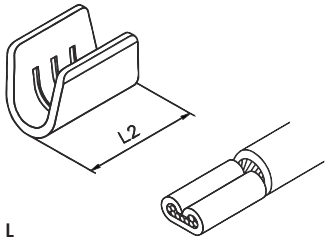
 <p>L</p>	RSB 7838 V-0,75		0,25-0,75	CuZn	○	●		3,7	0,3	99
			24-20	Z 8 C 17	○					

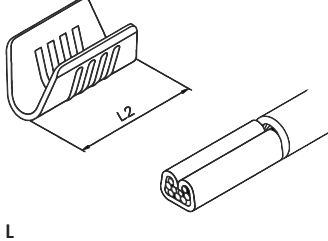
 <p>L</p>	RSB 7792.002 V-1,5	●	1-2	CuZn	●	●		6,0	0,3	40
		●	18-14	Fe			●			

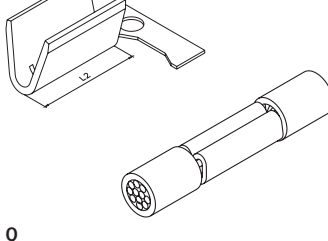
 <p>Q</p>	RSB 7825.001 V-1		0,5-1,5	CuZn	●	○		5,8	0,3	16
			20-16	Fe			○			
	RSB 8059 V-2,5		1,5-2,5	CuZn	○	○		6,4	0,4	6
			16-14	Fe			○			

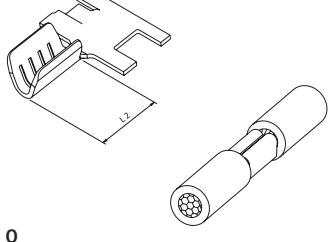
 <p>Q</p>	RSB 8236		0,5-1	CuZn	●	○		4,0	0,3	26
			22-18							

● Standard-Artikel / Standard parts ○ lieferbar auf Anfrage / available on request

ADERENDHÜLSEN END SPLICES

Bauform Q = Quertransport L = Längstransport Supply condition Q = transverse transport / Side feed L = longitudinal transport / End feed	Artikel-Nummer	DIN	UL	Leiterquer- schnitt	Material	Veredlung			Länge	Material- stärke	Verp.-Einh. Bandform
	Part number	DIN	UL	Wire size	Material	Finishing			Length	Material thickness	Packing unit Chain form
						blank	Sn	Ni			
				mm ² AWG		un- plated	Sn	Ni	L 2 mm	mm	x 1000

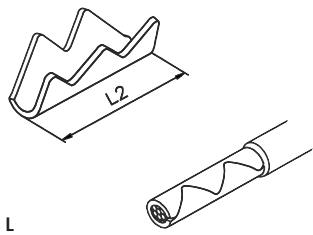

RSB 7999 V-0,5				0,14-0,5 24-20	CuZn Fe	●	●		4,2	0,2	90
	RSB 7929 V-1			0,5-1 20-18	CuZn Fe	●	●		6,0	0,25	60

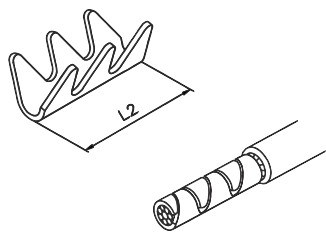

RSB 7849 V-1	46228 T3	●	0,5-1 20-18	CuZn Fe	●	●		6,1	0,25	60
							●			
RSB 7908 V-1,5			0,5-1,5 20-18	CuZn Fe	●	●		6,0	0,3	40

● Standard-Artikel / Standard parts ○ lieferbar auf Anfrage / available on request

Bauform Q = Quertransport L = Längstransport	Artikel-Nummer	Freigabens. Seite 7/8	Leiterquerschnitt	Material	Veredlung			Länge	Materialstärke	Verp.-Einh. Bandform
					blank	Sn	Ni			
Supply condition Q = transverse transport / Side feed L = longitudinal transport / End feed	Part number	Approvals s. page 7/8	Wire size	Material	Finishing			Length	Material thickness	Packing unit Chain form
					un-plated	Sn	Ni			
			mm ² AWG					L 2 mm	mm	x 1000

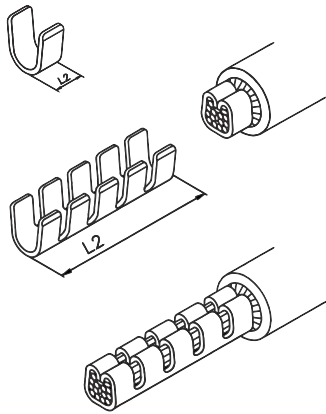

L

RSB 7735.001 V-1,5		0,5-1,5 20-16	CuZn	●	●	○	(1x) 1,5	0,3	99
			Fe			●	(2x) 3,8		
			CuSn	○	○		(3x) 6,1		
							(4x) 8,4		
							(5x) 10,7		
RSB 7837 V-2,5		1,5-2,5 16-14	CuZn	●	●		(1x) 1,5	0,3	99
			Fe			●	(2x) 3,8		
							(3x) 6,1		
							(4x) 8,4		
							(5x) 10,7		
RSB 7894 V-4	●	2,5-4 14-12	CuZn	●	●		(1x) 1,5	0,25	80
			CuSn	○	○		(2x) 4,0		
							(3x) 6,5		
RSB 7912 V-10		6-10 10-7	CuZn	●	●		(1x) 2,9	0,5	30
			Fe				(2x) 6,65		
							(3x) 10,4		
							(4x) 14,15		
RSB 8412 V-16		10-16 6	CuZn	●	○		(1x) 2,8	0,5	20
							(2x) 6,4		
							(3x) 10,0		
							(4x) 13,6		
							(5x) 17,2		

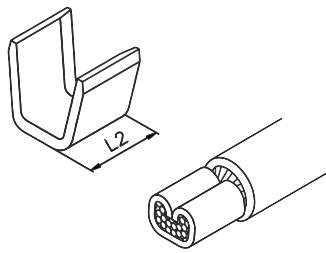

L

RSB 7791 V-6		2,5-<6 12-10	CuZn	●	●		(1x) 5,0	0,5	25
			CuSn	○	○		(2x) 11,5		
RSB 7791.001 V-6		2,5-6 12-10	CuZn	○	○		(1x) 4,0	0,5	25
			CuSn	○	○		(2x) 10,5		

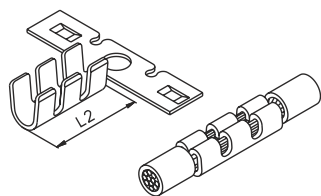

Q

RSB 8006 V-1,5		0,5-1,5 20-16	CuZn	●	●		6,1	0,3	16
			Fe			○			
			Z 8 C 17	○					

● Standard-Artikel / Standard parts ○ lieferbar auf Anfrage / available on request

ADERENDHÜLSEN END SPLICES

Bauform Q = Quertransport L = Längstransport Supply condition Q = transverse transport / Side feed L = longitudinal transport / End feed	Artikel-Nummer	DIN	UL	Leiterquer- schnitt	Material	Veredlung			Länge		Material- stärke	Verp.-Einh. Bandform
	Part number	DIN	UL	Wire size		Material	Finishing			Length		
					blank		Sn	Ni	L 1 mm	L 2 mm	mm	x 1000

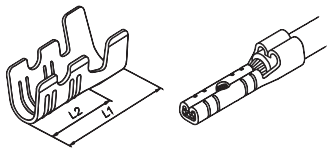

L

RSB 7770 V-1	46228 T2			0,5-1	CuZn	●	●		11,0	7,0	0,3	25
	B1-7			20-18	Fe			●				
RSB 7771 V-1,5	46228 T2			0,75-1,5	CuZn	●	●		11,0	7,0	0,3	20
	B1,5-7			18-16	Fe			●				
RSB 7832 V-2,5	46228 T2		●	1,5-2,5	CuZn	●	●		11,0	7,0	0,3	15
	B2,5-7			16-14	Fe			○				

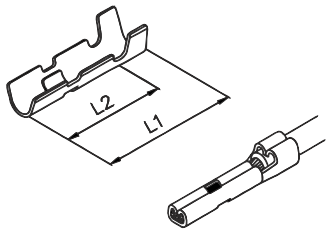

L

RSB 7806 V-1				0,5-1 20-18	CuZn	○	○		13,0	9,0	0,25	22
---------------------	--	--	--	----------------	------	---	---	--	------	-----	------	----

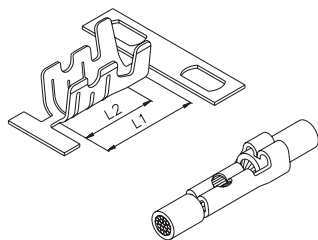

Q

RSB 8061 V-1,5	46228 T2			0,75-1,5 18-16	CuZn	○	○		7,4	4,6	0,3	4
	B 1,5-7				Fe			●				

● Standard-Artikel / Standard parts ○ lieferbar auf Anfrage / available on request

Bauform Q = Quertransport L = Längstransport Supply condition Q = transverse transport / Side feed L = longitudinal transport / End feed	Artikel-Nummer Part number	DIN UL	Leiterquer- schnitt Wire size mm ² AWG	Material	Veredlung			Länge		Material- stärke	Verp.-Einh. Bandform Packing unit Chain form x 1000
					blank	Sn	Ni	L 1 mm	L 2 mm		
					un- plated	Sn	Ni				

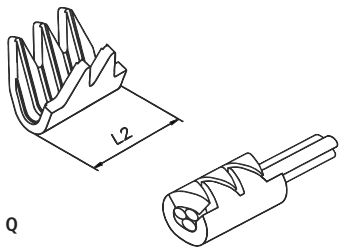
 <p>Q</p>	RVB 8131 V-0,6 Für Lackdraht For magnet wire		0,2-0,6 24-20	CuZn	○	○		3,2	0,45	30

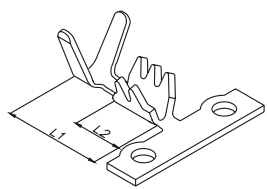
 <p>Q</p>	RVB 8131.001 V-06 für Lackdraht For magnet wire		0,2-0,6 24-20	CuZn	○	●		6,7	3,2	0,45	30

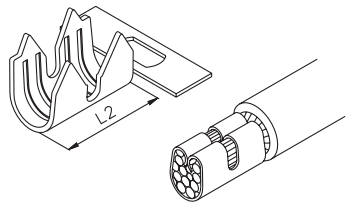
 <p>Q</p>	RSB 7884.001 V 0-10		4-10 12-10	CuZn	●	○		10,0	0,3	4
	RSB 7884.003 V 0-10		4-10 12-10	CuZn		○		10,0	0,5	4

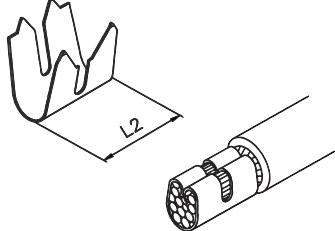
 <p>Q</p>	RSB 7884.004 V 0-16		10-16 10-6	CuZn	○	○		10,0	0,5	2,5

● Standard-Artikel / Standard parts ○ lieferbar auf Anfrage / available on request

RUNDSTECKHÜLSEN SOCKETS

Bauform Q = Quertransport L = Längstransport Supply condition Q = transverse transport / Side feed L = longitudinal transport / End feed	Artikel-Nummer	Freigabe s. Seiten 7/8	Leiterquer- schnitt	Material	Veredlung			Innen Ø	Länge		Material- stärke	Verp.-Einh. Bandform
	Part number	Approvals s. page 7/8	Wire size	Material	Finishing			Inside Ø	Length		Material thickness	Packing unit Chain form
			mm ² AWG		blank	Sn	Ni	mm	L 1 mm	L 2 mm	mm	x 1000

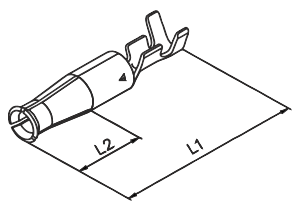

Q

RBB 7994.002 F 2,3-0,75			0,22-0,5 24-22	CuSn		●		2,36	21,0	7,6	0,4	4,5
RBB 7994.003 F 2,3-0,75 Mit Bohrung With hole			0,22-0,5 24-22	CuSn	●			2,36	21,0	7,6	0,4	2

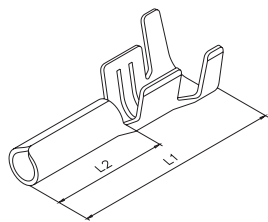

L

RBB 8110 R 1,85-1,5			1-1,5 18-16	CuZn Fe	○	○		1,83	14,3	7,2	0,3	10
RBB 8110.001 R 1,93-1,5			0,5-1,5 20-16	CuZn Fe	○	○		1,92	14,3	7,2	0,3	10

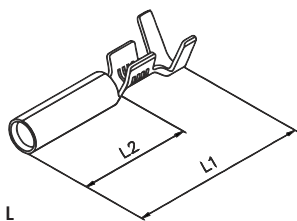

L

RBB 7995.003 R 1,2-1	●		0,5-1 20-18	X5CrNi	●			1,29	12,0	4,5	0,4	20
RBB 7995.005 R 1,4-1			0,5-1 20-18	X5CrNi	●			1,49	12,0	4,5	0,4	20
RSB 7836 R 3,8-1			0,5-1 20-18	CuZn	○	○		3,85	20,7	10,0	0,4	8

● Standard-Artikel / Standard parts ○ lieferbar auf Anfrage / available on request

Bauform Q = Quertransport L = Längstransport Supply condition Q = transverse transport / Side feed L = longitudinal transport / End feed	Artikel-Nummer	Freigabe s. Seiten 7/8	Leiterquer- schnitt	Material	Veredlung			Innen Ø	Länge		Material- stärke	Verp.-Einh. Bandform
	Part number	Approvals s. page 7/8	Wire size mm ² AWG	Material	Finishing			Inside Ø	Length		Material thickness mm	Packing unit Chain form x 1000
					blank	Sn	Ni		L 1 mm	L 2 mm		

Leicht aufsteckbar
Low insertion force

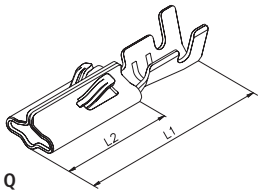

Q

RFB 8185 R 1,3-0,75 Für Gehäusemontage For housings			0,35-0,75 22-18	CuSn	●	●		1,22	14,2	7,85	0,25	5,5
--	--	--	--------------------	------	---	---	--	------	------	------	------	-----

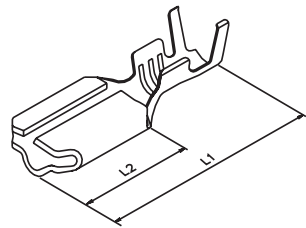

L

RFB 8121.115 R 1,5-1,5 Leicht aufsteckbar Low insertion force			0,5-1,5 20-16	Fe			●	1,38	14,3	6,3	0,35	7
RFB 8121.020 R 2-1,5	●		0,5-1,5 20-16	Fe			○	1,87	14,3	6,3	0,35	7
RFB 8121.022 R 2,25-1,5			0,5-1,5 20-16	Fe			○	2,08	14,3	6,3	0,35	7
RFB 8121.025 R 2,5-1,5	●		0,5-1,5 20-16	Fe			○	2,36	14,3	6,3	0,35	7

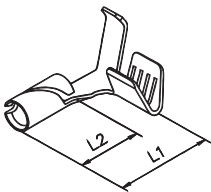

L

RBB 8069 R 1,9-1,5			0,75-1,5 18-16	Fe			●	1,9	9,0	5,0	0,32	5
RBB 8069.001 R 1,95-1,5			0,75-1,5 18-16	CuZn	○	○		1,95	9,0	5,0	0,32	5
RBB 8069.002 R 1,95-0,34			0,14-0,34 26-22	CuZn	○			1,95	9,0	5,0	0,30	5

● Standard-Artikel / Standard parts ○ lieferbar auf Anfrage / available on request

RUNDSTIFTE SOCKETS

Bauform Q = Quertransport L = Längstransport Supply condition Q = transverse transport / Side feed L = longitudinal transport / End feed	Artikel-Nummer	Leiterquerschnitt	Material	Veredlung			Außen Ø	Länge		Materialstärke	Verp.-Einh. Bandform
	Part number	Wire size	Material	Finishing			Outside Ø	Length		Material thickness	Packing unit Chain form
				blank	Sn	Ni		L 1 mm	L 2 mm		
		mm ² AWG		un-plated	Sn	Ni	mm	mm	mm	x 1000	

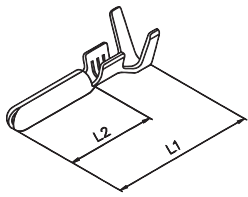

RTB 7861.003 P 2,4-0,75	0,5-0,75 20	CuZn	●			2,36	16,8	9,2	0,35	4

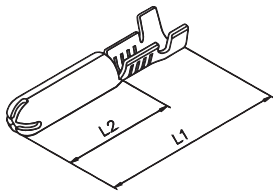

L

RSB 7835 P 4-1	0,5-1 20-18	CuZn	○	○		4,0	23,0	13,4	0,45	9

● Standard-Artikel / Standard parts ○ lieferbar auf Anfrage / available on request

Bauform Q = Quertransport L = Längstransport Supply condition Q = transverse transport / Side feed L = longitudinal transport / End feed	Artikel-Nummer	Leiterquerschnitt	Material	Veredlung			Abmessungen			Materialstärke	Verp.-Einh. Bandform
	Part number	Wire size	Material	Finishing			Dimensions			Material thickness	Packing unit Chain form
				blank	Sn	Ni	B mm	L 1 mm	L 2 mm		
		mm ² AWG		un-plated	Sn	Ni				mm	x 1000

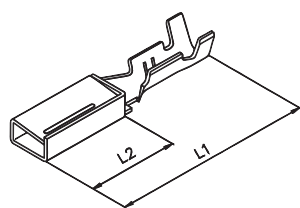

Q

RFB 8007.001 V 2-1,5	0,34-1 22-18	CuZn	○	○			24,1	10,5	0,4	3,5

● Standard-Artikel / Standard parts ○ lieferbar auf Anfrage / available on request

ISOLIERKÖRPER INSULATION HOUSINGS

- Isolierkörper 2,8 - 4,8 - 6,3 mm
- Gehäuse für Standard- und leicht aufsteckbare Flachsteckhülsen, gerade Ausführung

- Insulation housings 2,8 - 4,8 - 6,3 mm
- Housings for standard and low insertion force receptacles, straight version

Bauform	Artikel-Nummer	Material	Brennbarkeitsklasse			Farbe	Polzahl	Abmessungen mm				Verp.-Einh.	Zugehörige Artikel
Supply condition	Part number	Material	Flammability class			Colour	Positions	Dimensions mm				Packing unit	Fitting parts
			V 0	V 2	GWT 750 °C *			L	B	H	H 1	x 1000	

2,8 mm

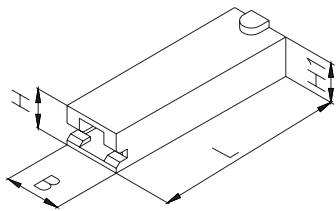

EH 657.100	PA 66	●			natur	1	19,8	5,2	4,0	4,6	50	RSB 7785 RSB 7990 RSB 8100
	PA 6/66	●			natur							
EH 657.100-G	PA 6		●	●								
EH 657.100	PA 66		●		schwarz	1	19,8	5,2	4,0	4,6	50	RSB 7785 RSB 7990 RSB 8100
	PA 46		●		black							
EH 657.100-G	PA 6/66	●										
	PA 6		●	●								

4,8 mm

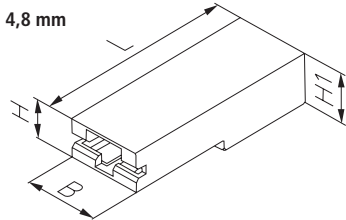

EH 650.100	PA 66		●		natur	1	20,0	8,0	5,4	6,0	25	RSB 7603 RSB 7604 RSB 8270
	PA 6/66	●			natur							
EH 650.100-G	PA 6		●	●								
EH 650.100	PA 46		●		schwarz	1	20,0	8,0	5,4	6,0	25	RSB 7603 RSB 7604 RSB 8270
					black							

6,3 mm

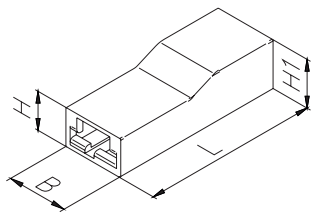

EH 649	PA 66		●		natur	1	25,0	9,5	4,8	6,2	15	RSB 8115 RSB 7900 RSB 7901 RSB 8152 RSB 8260	
	PA 6/66	●			natur								
EH 649-G	PA 6		●	●									
EH 649	PA 66		●		schwarz	1	25,0	9,5	4,8	6,2	15		RSB 8115 RSB 7900 RSB 7901 RSB 8152 RSB 8260
	PA 6/66	●			black								
EH 649-G	PA 6		●	●									
EH 681	PA 66		●		natur	1	25,0	9,15	5,2	6,1	15	RSB 8137 RSB 8238.158 RSB 8238.258 RSB 8136 (3 mm² max.)	
	PA 6/66	●			natur								
EH 681-G	PA 6		●	●									
EH 681	PA 66		●		schwarz	1	25,0	9,15	5,2	6,1	15		RSB 8137 RSB 8238.158 RSB 8238.258 RSB 8136 (3 mm² max.)
	PA 6/66	●			black								
EH 681-G	PA 6		●	●									

* glühdrahtbeständig, GWT 750 °C nach IEC 60335-1 – glow wire resistant, GWT 750 °C. acc. to IEC 60335-1

Andere Materialien und Farben auf Anfrage – Other materials / colors on request
Freigaben: siehe Seite 9 – Approvals: see page 9

- Isolierkörper 4,8 - 6,3 mm
- Gehäuse für Standard- und leicht aufsteckbare Flachsteckhülsen, Winkelausführung

- Insulation housings 4,8 - 6,3 mm
- Housings for standard and low insertion force receptacles, flag type version

Bauform	Artikel-Nummer	Material	Brennbarkeitsklasse			Farbe	Polzahl	Abmessungen mm				Verp.-Einh.	Zugehörige Artikel
Supply condition	Part number	Material	Flammability class			Colour	Positions	Dimensions mm				Packing unit	Fitting parts
			V 0	V 2	GWT 750 °C *			L	B	H	H 1	x 1000	

4,8 mm

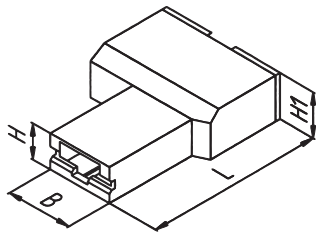

EH 683.002	PA 66		●			natur	1	14,2	7,5	4,4	5,2	20	RSB 7936.002 RSB 7936.003 RSB 8186.155 RSB 8186.158	
	PA 6/66	●				natur								
EH 683.002-G	PA 6			●	●									
EH 683.002	PA 66			●		schwarz black	1	14,2	7,5	4,4	5,2	20		
	PA 46			●										
	PA 6/66	●												
EH 683.002-G	PA 6			●	●									

6,3 mm

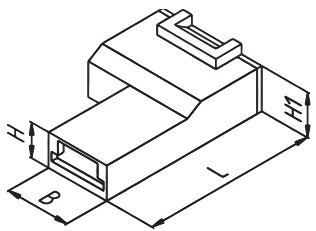

EH 678.100-B	PA 66	●		●		natur	1	16,2	9,6	4,8	5,7	15	RSB 7944 RSB 8240.158
						natur							
EH 678.100	PA 66			●		schwarz black	1	16,2	9,6	4,8	5,7	15	
EH 679.200	PA 66			●		natur	1	18,8	9,6	4,8	6,2	15	RSB 8138 RSB 8198.1208
	PA 6/66	●											
EH 679.200-G	PA 6			●	●								
EH 679.200	PA 66			●		schwarz black	1	18,8	9,6	4,8	6,2	15	
	PA 6/66	●											

6,3 mm

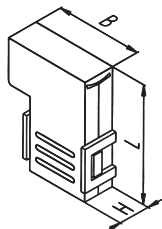

EH 658.100	PA 66			●		natur	1	18,0	13,4	5,2		12,5	RSB 8138
EH 658.100-G	PA 6			●	●								
EH 658.100	PA 66			●		schwarz black	1	18,0	13,4	5,2		12,5	
EH 658.100-G	PA 6			●	●								

* glühdrahtbeständig, GWT 750 °C nach IEC 60335-1 – glow wire resistant, GWT 750 °C. acc. to IEC 60335-1

Andere Materialien und Farben auf Anfrage – Other materials / colors on request
Freigaben: siehe Seite 9 – Approvals: see page 9

ISOLIERKÖRPER INSULATION HOUSINGS

- Isolierkörper 2,8 - 4,8 mm
- Gehäuse für verriegelbare Flachsteckhülsen
- Insulation housings 2,8 - 4,8 mm
- Housings for self locking receptacles

Bauform	Artikel-Nummer	Material	Brennbarkeitsklasse			Farbe	Polzahl	Abmessungen mm				Verp.-Einh.	Zugehörige Artikel
Supply condition	Part number	Material	Flammability class			Colour	Positions	Dimensions mm				Packing unit	Fitting parts
			V 0	V 2	GWT 750 °C *			L	B	H	H 1	x 1000	

2,8 mm
Gerade Ausführung
Straight version

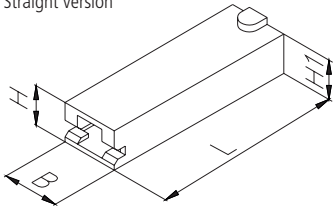

EH 761	PA 66		○		natur natural	1	21,0	5,2	4,7	4,7	50	RSB 8261.055 RSB 8261.058 RSB 8261.105 RSB 8261.108 RSB 8261.2055 RSB 8261.2058 RSB 8261.2105 RSB 8261.2108
EH 761-G	PA 66	●		●								

4,8 mm
Gerade Ausführung
Straight version

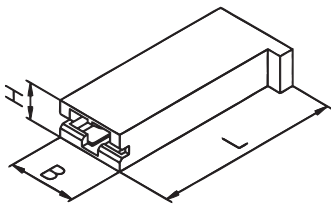

EH 694	PA 66	●	●		natur natural	1	23,0	7,4	5,2		15	RSB 8168.055 RSB 8168.058 RSB 8168.155 RSB 8168.158
EH 694-G	PA 6		●									
EH 694	PA 66	●	●		schwarz black							
EH 694-G	PA 6		●	●								

4,8 mm
Gerade Ausführung
Straight version

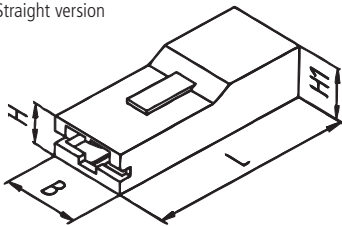

EH 680	PA 66		●		natur natural	1	23,0	7,2	4,5	6,0	25	RSB 8028 RSB 8029
	PA 6/66	●										
EH 680-G	PA 6		●	●								
EH 680	PA 66		●		schwarz black							
	PA 6/66	●										

* glühdrahtbeständig, GWT 750 °C nach IEC 60335-1 – glow wire resistant, GWT 750 °C. acc. to IEC 60335-1

Andere Materialien und Farben auf Anfrage – Other materials / colors on request
Freigaben: siehe Seite 9 – Approvals: see page 9

- Isolierkörper 6,3 mm
- Gehäuse für Flachsteckhülsen und Flachstecker
- Insulation housings 6,3 mm
- Housings for receptacles and tabs

Bauform	Artikel-Nummer	Material	Brennbarkeitsklasse			Farbe	Polzahl	Abmessungen mm				Verp.-Einh.	Zugehörige Artikel
Supply condition	Part number	Material	Flammability class			Colour	Positions	Dimensions mm				Packing unit	Fitting parts
			V 0	V 2	GWT 750 °C *			L	B	H	H 1	x 1000	

Gerade Ausführung
Straight version

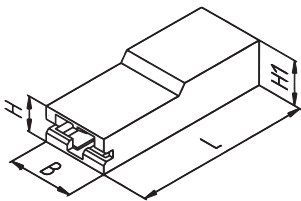

EH 677	PA 66		●		natur	1	25,0	9,3	5,0	6,3	10	RSB 7960 RSB 7960.020 RSB 7961 RSB 7961.020
					natur							
EH 677-G	PA 66	●		●								
EH 677	PA 66		●		schwarz	1	25,0	9,3	5,0	6,3	10	RSB 8178.108 RSB 8178.258 RSB 8178.308
					black							
EH 677-G	PA 66	●		●								
EH 777	PA 66		●		natur	1	25,0	9,3	5,0	6,3	15	RSB 8178.108 RSB 8178.258 RSB 8178.308
					natur							
EH 777-G	PA 66	●		●								
EH 777	PA 66		●		schwarz	1	25,0	9,3	5,0	6,3	15	RSB 8178.108 RSB 8178.258 RSB 8178.308
					black							
EH 777-G	PA 66	●		●								

Gerade Ausführung, für Flachstecker
Straight version, for tabs

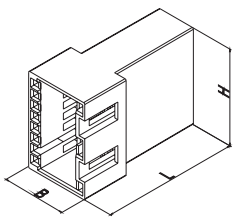

EH 788-002-**	PA 6		●	●	natur	2	31,8	14,9	12,3	4	RMB 7831.010 RMB 7833.010 ***
	PA 66	●			natur						
EH 788-003-**	PA 6		●	●	natur	3	31,8	14,9	17,3	3	RMB 7831.010 RMB 7833.010 ***
	PA 66	●			natur						
EH 788-004-**	PA 6		●	●	natur	4	31,8	14,9	22,3	2,5	RMB 7831.010 RMB 7833.010 ***
	PA 66	●			natur						
EH 788-005-**	PA 6		●	●	natur	5	31,8	14,9	27,3	2	RMB 7831.010 RMB 7833.010 ***
	PA 66	●			natur						
EH 788-006-**	PA 6		●	●	natur	6	31,8	14,9	32,3	2	RMB 7831.010 RMB 7833.010 ***
	PA 66	●			natur						

Codierung nach RAST 5
Codification according to
connector system RAST 5

* glühdrahtbeständig, GWT 750 °C nach IEC 60335-1 – glow wire resistant, GWT 750 °C. acc. to IEC 60335-1

** Abartennummer gemäß RAST 5 Codiertabelle – Version number as per the RAST 5 polarizing chart

*** Ø max Isolierung / insulation = 3,1mm

Andere Materialien und Farben auf Anfrage – Other materials / colors on request

Freigaben: siehe Seite 9 – Approvals: see page 9

ISOLIERKÖRPER INSULATION HOUSINGS

- Isolierkörper 6,3 mm
- Mehrfachgehäuse für Flachsteckhülsen
- Insulation housings 6,3 mm
- Multi-way housings for receptacles

Bauform	Artikel-Nummer	Material	Brennbarkeitsklasse			Farbe	Polzahl	Abmessungen mm			Verp.-Einh.	Zugehörige Artikel
Supply condition	Part number	Material	Flammability class			Colour	Positions	Dimensions mm			Packing unit	Fitting parts
			V 0	V 2	GWT 750 °C *			L	B	H	x 1000	

Gerade Ausführung
Straight version

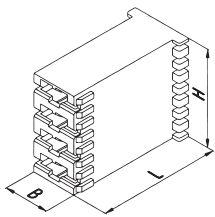

Codierung nach RAST 5
Codification according to
connector system RAST 5

EH 688-002-**	PA 6	●		●	natur	2	25,0	9,2	10	5	RSB 8178.108
					natural						RSB 8178.258

EH 688-003-**	PA 6	●		●	natur	3	25,0	9,2	15	3,5	RSB 8178.108
					natural						RSB 8178.258

EH 688-004-**	PA 6	●		●	natur	4	25,0	9,2	20	2,5	RSB 8178.108
					natural						RSB 8178.258

EH 688-005-**	PA 6	●		●	natur	5	25,0	9,2	25	1,5	RSB 8178.108
					natural						RSB 8178.258

EH 688-006-**	PA 6	●		●	natur	6	25,0	9,2	30	1	RSB 8178.108
					natural						RSB 8178.258

EH 688-007-**	PA 6	●		●	natur	7	25,0	9,2	35	0,5	RSB 8178.108
					natural						RSB 8178.258

EH 688-008-**	PA 6	●		●	natur	8	25,0	9,2	40	0,5	RSB 8178.108
					natural						RSB 8178.258

Gerade Ausführung
Straight version

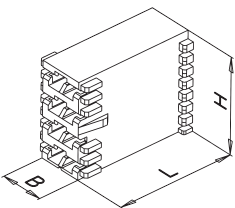

Codierung nach RAST 5
Codification according to
connector system RAST 5

EH 688.400-002-**	PA 6	●		●	natur	2	25,0	9,2	10	5	RSB 8178.1108
					natural						RSB 8178.1258

EH 688.400-003-**	PA 6	●		●	natur	3	25,0	9,2	15	3,5	RSB 8178.1108
					natural						RSB 8178.1258

EH 688.400-004-**	PA 6	●		●	natur	4	25,0	9,2	20	2,5	RSB 8178.1108
					natural						RSB 8178.1258

EH 688.400-005-**	PA 6	●		●	natur	5	25,0	9,2	25	1,5	RSB 8178.1108
					natural						RSB 8178.1258

EH 688.400-006-**	PA 6	●		●	natur	6	25,0	9,2	30	1	RSB 8178.1108
					natural						RSB 8178.1258

EH 688.400-007-**	PA 6	●		●	natur	7	25,0	9,2	35	0,5	RSB 8178.1108
					natural						RSB 8178.1258

EH 688.400-008-**	PA 6	●		●	natur	8	25,0	9,2	40	0,5	RSB 8178.1108
					natural						RSB 8178.1258

* glühdrahtbeständig, GWT 750 °C nach IEC 60335-1 – glow wire resistant, GWT 750 °C. acc. to IEC 60335-1

** Abartennummer gemäß RAST 5 Codiertabelle – Version number as per the RAST 5 polarizing chart

*** Ø max Isolierung / insulation = 3,1mm

Andere Materialien und Farben auf Anfrage – Other materials / colors on request

Freigaben: siehe Seite 9 – Approvals: see page 9

- Isolierkörper 6,3 mm
- Mehrfachgehäuse für Flachsteckhülsen
- Insulation housings 6,3 mm
- Multi-way housings for receptacles

Bauform	Artikel-Nummer	Material	Brennbarkeitsklasse			Farbe	Polzahl	Abmessungen mm			Verp.-Einh.	Zugehörige Artikel
Supply condition	Part number	Material	Flammability class			Colour	Positions	Dimensions mm			Packing unit	Fitting parts
			V 0	V 2	GWT 750 °C *			L	B	H	x 1000	

Raster 5 mm
Pitch 5 mm

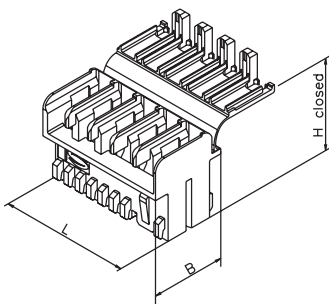

Codierung nach RAST 5
Codification according to
connector system RAST 5

EH 699-002-**	PA 6	●		●	natur	2	10	14,5	18	2	RSB 8240.1158 RSB 8240.1258
					natural						
EH 699-003-**	PA 6	●		●	natur	3	15	14,5	18	2	RSB 8240.1158 RSB 8240.1258
					natural						
EH 699-004-**	PA 6	●		●	natur	4	20	14,5	18	1	RSB 8240.1158 RSB 8240.1258
					natural						
EH 699-005-**	PA 6	●		●	natur	5	25	14,5	18	1	RSB 8240.1158 RSB 8240.1258
					natural						
EH 699-006-**	PA 6	●		●	natur	6	30	14,5	18	0,5	RSB 8240.1158 RSB 8240.1258
					natural						
EH 699-007-**	PA 6	●		●	natur	7	35	14,5	18	0,5	RSB 8240.1158 RSB 8240.1258
					natural						
EH 699-008-**	PA 6	●		●	natur	8	40	14,5	18	0,5	RSB 8240.1158 RSB 8240.1258
					natural						

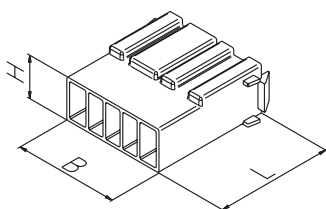

Codierung nach RAST 5
Codification according to
connector system RAST 5

EH 798-003-025-960-G	PA 6		●	●	natur	3	30	17	11	15	3 x RMB 7831.010
					natural						
EH 798-003-025-960	PA 6/66	●									
EH 798-005-020-960	PA 6/66	●			natur	5	30	27	11	15	5 x RMB 7831.010
					natural						

* glühdrahtbeständig, GWT 750 °C nach IEC 60335-1 – glow wire resistant, GWT 750 °C. acc. to IEC 60335-1

** Abartennummer gemäß RAST 5 Codetabelle – Version number as per the RAST 5 polarizing chart

Andere Materialien und Farben auf Anfrage – Other materials / colors on request
Freigaben: siehe Seite 9 – Approvals: see page 9

ISOLIERKÖRPER INSULATION HOUSINGS

- Isolierkörper 2,8 mm
- Gehäuse für Flachsteckhülsen und Flachstecker
- Insulation housings 2,8 mm
- Housings for receptacles and tabs

Bauform	Artikel-Nummer	Material	Brennbarkeitsklasse			Farbe	Polzahl	Abmessungen mm				Verp.-Einh.	Zugehörige Artikel
Supply condition	Part number	Material	Flammability class			Colour	Positions	Dimensions mm				Packing unit	Fitting parts
			V 0	V 2	GWT 750 °C *			L	B	H	H 1	x 1000	

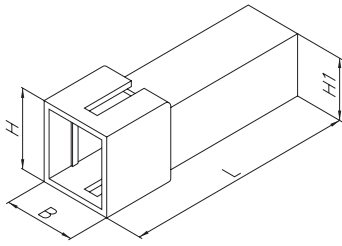

EH 701	PA 66		●			natur natural	1	25,8	8,5	8,5	6,6	15	RMB 8039.001 RMB 8039.003
EH 701-G	PA 6		●	●									

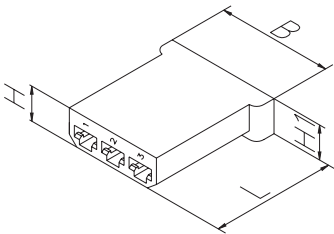

EH 728	PA 66		●			natur natural	3	18,0	19,2	5,0		15	3 x RSB 8280.1055 3 x RSB 8280.1058 3 x RSB 8280.1105 3 x RSB 8280.1108
---------------	-------	--	---	--	--	------------------	---	------	------	-----	--	----	--

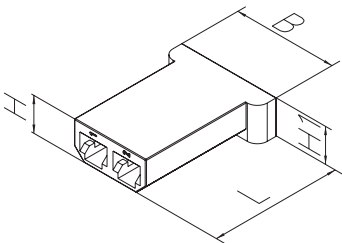

EH 727.001	PA 6		●	●		natur natural	2	18,0	14,2	5,0		15	2 x RSB 8280.1055 2 x RSB 8280.1058 2 x RSB 8280.1105 2 x RSB 8280.1108
EH 727.002	PA 6		●	●		schwarz black							

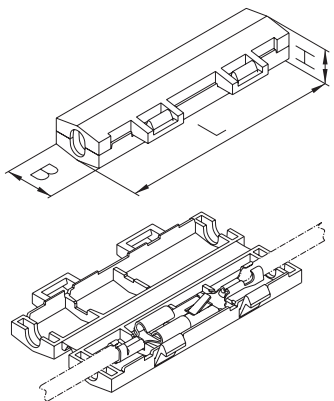

EH 718.100	PA 6		●			natur natural	1	51,25	11,5	8		2,5	RSB 7900 RSB 7960.020 RSB 8260.158 RSB 8260.258 + RMB 7831.010 RMB 7840 RSB 8028 RSB 8270.158 RSB 7604.258 + RMB 8165.108 Weitere Artikel auf Anfrage Other parts on request
-------------------	------	--	---	--	--	------------------	---	-------	------	---	--	-----	---

* glühdrahtbeständig, GWT 750 °C nach IEC 60335-1 – glow wire resistant, GWT 750 °C. acc. to IEC 60335-1

Andere Materialien und Farben auf Anfrage – Other materials / colors on request
Freigaben: siehe Seite 9 – Approvals: see page 9

- Isolierkörper 6,3 mm
- Gehäuse für Flachsteckhülsen und Flachstecker
- Insulation housings 6,3 mm
- Housings for receptacles and tabs

Bauform	Artikel-Nummer	Material	Brennbarkeitsklasse			Farbe	Polzahl	Abmessungen mm				Verp.-Einh.	Zugehörige Artikel
Supply condition	Part number	Material	Flammability class			Colour	Positions	Dimensions mm				Packing unit	Fitting parts
			V 0	V 2	GWT 750 °C *			L	B	H	H 1	x 1000	

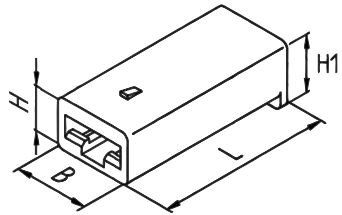
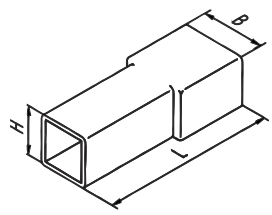

VV 2023.100	PA 66		●			natur	1	31,6	12,5	9,3		6,5	1 x RMB 7831.010 1 x RMB 7833.010
	PA 6/66	●				natur							
VV 2023.100-G	PA 6			●	●								
VV 2023.100	PA 66		●			schwarz							
						black							
VV 2023.200	PA 66		●	●		natur	1	23,0	9,9	6,5	8,1	13	1 x RSB 7858 1 x RSB 7916
						natur							
VV 2023.200-G	PA 6			●	●								
VV 2023.200	PA 66		●	●		schwarz							
						black							

Raster 8 mm
Pitch 8 mm

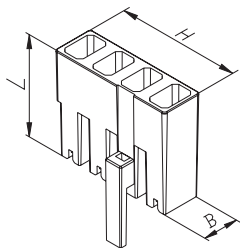

EH 700/1	PPS	●				schwarz	1	25,2	10,2	7		2	RSB 8220.1158
						black							
EH 700/2	PPS	●				schwarz	2	25,2	10,2	15		2	RSB 8220.1158
						black							
EH 700/3	PPS	●				schwarz	3	25,2	10,2	23		2	RSB 8220.1158
						black							
EH 700/4	PPS	●				schwarz	4	25,2	10,2	31		2	RSB 8220.1158
						black							

* glühdrahtbeständig, GWT 750 °C nach IEC 60335-1 – glow wire resistant, GWT 750 °C. acc. to IEC 60335-1

Andere Materialien und Farben auf Anfrage – Other materials / colors on request
Freigaben: siehe Seite 9 – Approvals: see page 9

ISOLIERKÖRPER INSULATION HOUSINGS

- Isolierkörper 6,3 mm
 - Mehrfachgehäuse für Flachsteckhülsen und Flachstecker
- Insulation housings 6,3 mm
 - Multi-way housings for receptacles and tabs

Bauform	Artikel-Nummer	Material	Brennbarkeitsklasse			Farbe	Polzahl	Abmessungen mm				Verp.-Einh.	Zugehörige Artikel
Supply condition	Part number	Material	Flammability class			Colour	Positions	Dimensions mm				Packing unit	Fitting parts
			V 0	V 2	GWT 750 °C *			L	B	H	H 1	x 1000	

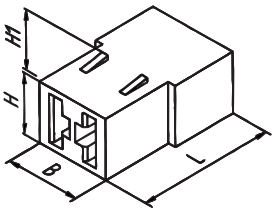
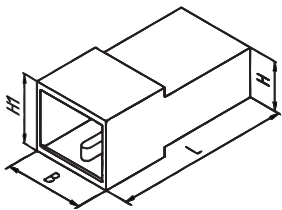

VV 2025.100	PA 66		●			natur natural	2	31,5	15,0	9,3	13,0	4	2 x RMB 7831.010 2 x RMB 7833.010
	VV 2025.100-G	PA 6		●	●								
VV 2025.100	PA 46		●										
VV 2025.100	PA 66		●			schwarz black							
VV 2025.200	PA 66		●			natur natural	2	23,0	12,5	10,0	11,4	6,5	2 x RSB 7858 2 x RSB 7916
	PA 46		●										
VV 2025.200-G	PA 6		●	●									
VV 2025.200	PA 66		●			schwarz black							

* glühdrahtbeständig, GWT 750 °C nach IEC 60335-1 – glow wire resistant, GWT 750 °C. acc. to IEC 60335-1

Andere Materialien und Farben auf Anfrage – Other materials / colors on request
Freigaben: siehe Seite 9 – Approvals: see page 9

- Isolierkörper 6,3 mm
- Mehrfachgehäuse für Flachsteckhülsen und Flachstecker
- Insulation housings 6,3 mm
- Multi-way housings for receptacles and tabs

Bauform	Artikel-Nummer	Material	Brennbarkeitsklasse			Farbe	Polzahl	Abmessungen mm				Verp.-Einh.	Zugehörige Artikel
Supply condition	Part number	Material	Flammability class			Colour	Positions	Dimensions mm				Packing unit	Fitting parts
			V 0	V 2	GWT 750 °C *			L	B	H	H 1	x 1000	

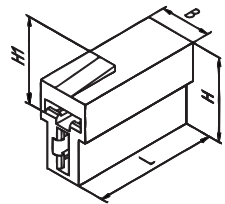
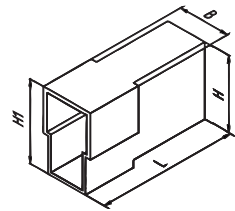

VV 2041.100	PA 66		●			natur natural	2	31,6	12,5	18,0	20,0	3,5	2 x RMB 7831.010 2 x RMB 7833.010
VV 2041.100-G	PA 6		●	●									
VV 2041.200	PA 66		●			natur natural	2	23,0	10,0	16,6	18,0	7	2 x RSB 7858 2 x RSB 7916
VV 2041.200-G	PA 6		●	●									

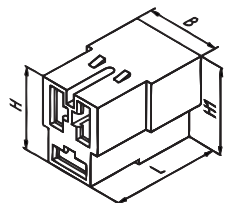
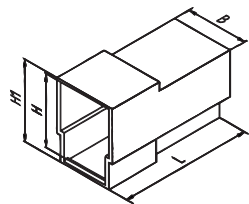

VV 2027.100	PA 66		●			schwarz black	3	31,7	15,2	17,7	19,8	2,5	3 x RMB 7831.010 3 x RMB 7833.010
VV 2027.100	PA 66		●			natur natural							
VV 2027.100-G	PA 6		●	●									
VV 2027.200	PA 66		●			natur natural	3	23,0	15,2	16,6	17,8	4	3 x RSB 7858 3 x RSB 7916
VV 2027.200-G	PA 6		●	●									
VV 2027.200	PA 66		●			schwarz black							

* glühdrahtbeständig, GWT 750 °C nach IEC 60335-1 – glow wire resistant, GWT 750 °C. acc. to IEC 60335-1

Andere Materialien und Farben auf Anfrage – Other materials / colors on request
Freigaben: siehe Seite 9 – Approvals: see page 9

ISOLIERKÖRPER INSULATION HOUSINGS

- Isolierkörper 6,3 mm
- Mehrfachgehäuse für Flachsteckhülsen und Flachstecker
- Insulation housings 6,3 mm
- Multi-way housings for receptacles and tabs

Bauform	Artikel-Nummer	Material	Brennbarkeitsklasse			Farbe	Polzahl	Abmessungen mm				Verp.-Einh.	Zugehörige Artikel
Supply condition	Part number	Material	Flammability class			Colour	Positions	Dimensions mm				Packing unit	Fitting parts
			V 0	V 2	GWT 750 °C *			L	B	H	H 1	x 1000	

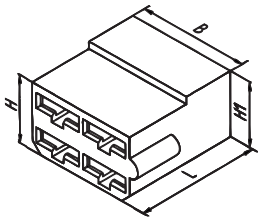
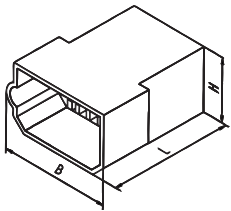

VV 2026.100	PA 66		●			natur natural	4	32,3	28,5	16,4		1,75	4 x RMB 7831.010 4 x RMB 7833.010
VV 2026.100-G	PA 6		●	●									
VV 2026.100	PA 66		●			schwarz black							
VV 2026.200	PA 66		●			natur natural	4	24,0	23,0	13,8	15,5	2,5	4 x RSB 7858 4 x RSB 7916
VV 2026.200-G	PA 6		●	●									
VV 2026.200	PA 66		●			schwarz black							

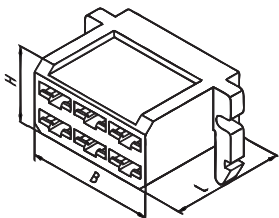
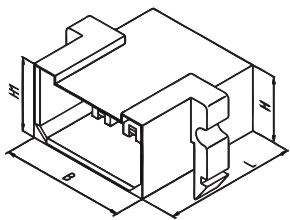

VV 2028.100	PA 66		●			natur natural	6	32,0	31,4	16,1	18,0	1	6 x RMB 7831.010 6 x RMB 7833.010
VV 2028.100-G	PA 6		●	●									
VV 2028.100	PA 66		●			schwarz black							
VV 2028.300	PA 66		●			natur natural	6	24,0	28,3	15,2		2	6 x RSB 7858 6 x RSB 7916

* glühdrahtbeständig, GWT 750 °C nach IEC 60335-1 – glow wire resistant, GWT 750 °C. acc. to IEC 60335-1

Andere Materialien und Farben auf Anfrage – Other materials / colors on request
Freigaben: siehe Seite 9 – Approvals: see page 9

- Isolierkörper 6,3 mm
 - Mehrfachgehäuse für Flachsteckhülsen und Flachstecker
- Insulation housings 6,3 mm
 - Multi-way housings for receptacles and tabs

Bauform	Artikel-Nummer	Material	Brennbarkeitsklasse			Farbe	Polzahl	Abmessungen mm				Verp.-Einh.	Zugehörige Artikel
Supply condition	Part number	Material	Flammability class			Colour	Positions	Dimensions mm				Packing unit	Fitting parts
			V 0	V 2	GWT 750 °C *			L	B	H	H 1	x 1000	

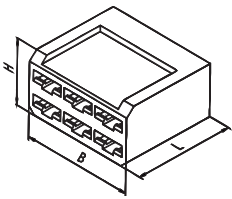
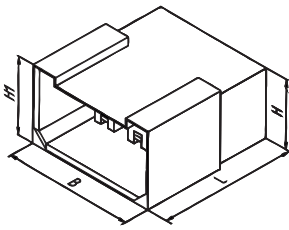

VV 2028.110	PA 66		●		natur natural	6	32,0	31,5	16,0	18,5	1,25	6 x RMB 7831.010 6 x RMB 7833.010
VV 2028.110-G	PA 6		●	●		6	32,0	31,5	16,0	18,5	1,25	6 x RMB 7831.010 6 x RMB 7833.010
VV 2028.110	PA 66		●		schwarz black	6	32,0	31,5	16,0	18,5	1,25	6 x RMB 7831.010 6 x RMB 7833.010
VV 2028.200	PA 66		●		natur natural	6	24,2	28,6	15,5	18,5	2,5	6 x RSB 7858 6 x RSB 7916
VV 2028.200-G	PA 6		●	●		6	24,2	28,6	15,5	18,5	2,5	6 x RSB 7858 6 x RSB 7916
VV 2028.200	PA 66		●		schwarz black	6	24,2	28,6	15,5	18,5	2,5	6 x RSB 7858 6 x RSB 7916

* glühdrahtbeständig, GWT 750 °C nach IEC 60335-1 – glow wire resistant, GWT 750 °C, acc. to IEC 60335-1

Andere Materialien und Farben auf Anfrage – Other materials / colors on request
Freigaben: siehe Seite 9 – Approvals: see page 9

ISOLIERKÖRPER INSULATION HOUSINGS

- Isolierkörper 6,3 mm
- Mehrfachgehäuse für Flachsteckhülsen und Flachstecker
- Insulation housings 6,3mm
- Multi-way housings for receptacles and tabs

Bauform	Artikel-Nummer	Material	Brennbarkeitsklasse			Farbe	Polzahl	Abmessungen mm				Verp.-Einh.	Zugehörige Artikel
Supply condition	Part number	Material	Flammability class			Colour	Positions	Dimensions mm				Packing unit	Fitting parts
			V 0	V 2	GWT 750 °C *			L	B	H	H 1	x 1000	

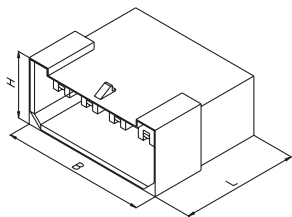
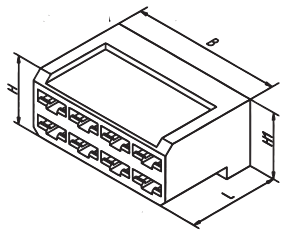
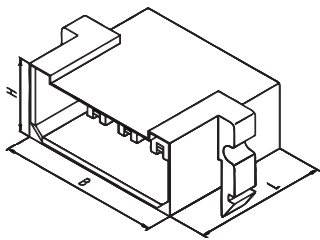

VV 2029.100	PA 66	●			natur natural	8	32,0	40,7	18,1		0,75	8 x RMB 7831.010 8 x RMB 7833.010
VV 2029.100	PA 66	●			schwarz black							
VV 2029.200	PA 66	●			natur natural	8	24,2	37,6	13,7	16,5	1,5	8 x RSB 7858 8 x RSB 7916
VV 2029.200	PA 66	●			schwarz black							
VV 2029	PA 66	●			natur natural	8	32,0	40,5	18,1		1	8 x RMB 7831.010 8 x RMB 7833.010

* glühdrahtbeständig, GWT 750 °C nach IEC 60335-1 – glow wire resistant, GWT 750 °C. acc. to IEC 60335-1

Andere Materialien und Farben auf Anfrage – Other materials / colors on request
Freigaben: siehe Seite 9 – Approvals: see page 9

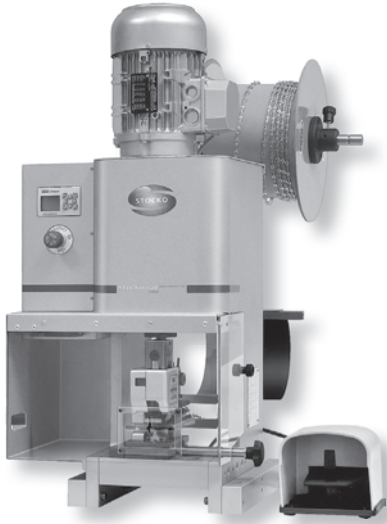

- WT 50
- Halbbauautomat zur Verarbeitung von Crimpkontakten in Bandform.

- WT 50
- Semi-automatic terminating machine for crimp contacts in bandolier form.

Merkmale

- Einfache Bedienung und Inbetriebnahme
- Elektromechanische Ansetzmaschine mit elektronisch gesteuertem Motor
- Zwei Stufen Geschwindigkeit regelbar (speziell für den Einsatz von IDC Werkzeugköpfen)
- Einsatz von Schnellwechselwerkzeugen für Längs- und Quertransport mit mechanischem Artikelvorschub
- Integrierte Abisoliervorrichtung (WT 50-3)
- Option: Crimpüberwachungssystem
- Anzeige der Zähler sowie Fehlermeldungen auf dem Display
- Zertifizierung nach CE

Main features

- Easy and clear to operate
- Electromechanical crimping machine with electronically controlled motor
- Speed adjustable in two levels (specifically for use of IDC tool heads)
- Suitable for quick-change tools for longitudinal and transverse transport with mechanical feed system
- Integrated stripper device (WT 50-3)
- Optional: crimping force monitoring system
- Counters and fault messages on the display
- Certification CE

Technische Daten

- Maschinentaktzeit 0,3 Sek.
umschaltbar auf 0,6 Sek.
- Leiterquerschnitt bis 6 mm²
(Crimplänge 5 mm,
Materialdicke 0,8 mm)
- Abmessungen
B x T x H mm 400 x 330 x 780
- Pressen-Nennkraft 25 kN
- Betriebsspannung 240 V (50-60 Hz)
- Steuerung elektronisch
- Gewicht 92 kg

Technical data

- Cycle time 0,3 sec.
switchable to 0.6 s
- Wire size up to 6 mm²
(crimp length 5 mm,
material thickness 0.8 mm)
- Dimensions
W x D x H mm 400 x 330 x 780
- Pressure rating 25 kN
- Operating voltage 240 V (50-60 Hz)
- Control electronic
- Weight 92 kg

STOCKOMAT CRIMP WT 50-3

Beschreibung wie WT 50, jedoch mit Abisoliervorrichtung

STOCKOMAT CRIMP WT 50-3

Description as for WT 50, but with stripper device

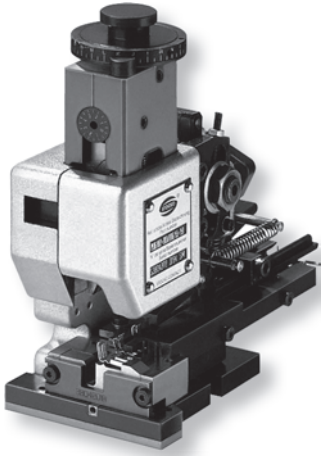

Schnellwechselwerkzeuge für Längstransport

Schnellwechselwerkzeug für Artikel, die hintereinander angebonden sind.
Der Vorschub erfolgt mechanisch.
Diese Variante ist geeignet für die Verarbeitung von Artikeln bis max. 31 mm Transportlänge.
Option: Werkzeug mit pneumatischem Vorschub.

Quick-change tools for longitudinal transport

Quick-change tool for products which are mounted in line.
Mechanical feed system.
This version is suitable for terminating products with up to 31 mm feed length.
On option, we can provide a pneumatic feed system.

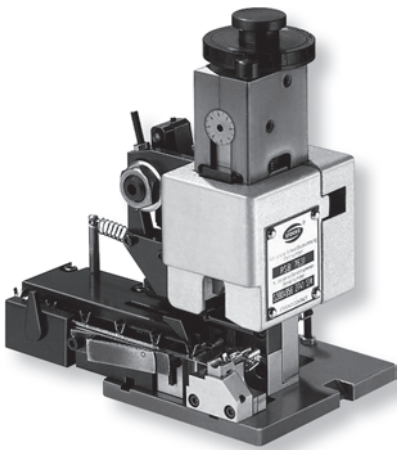

Schnellwechselwerkzeuge für Quertransport

Schnellwechselwerkzeug für Artikel, die quer an den Transportstreifen angebonden sind.
Der Vorschub erfolgt mechanisch.
Diese Variante ist geeignet für die Verarbeitung von Artikeln bis max. 25 mm Transportlänge.
Option: Werkzeug mit pneumatischem Vorschub.

Quick-change tools for transverse transport

Quick-change tool for products which are mounted side by side on the carrier strip.
Mechanical feed system.
This version is suitable for terminating products with up to 25 mm feed length.
On option, we can provide a pneumatic feed system.

UL-Freigaben und eine einwandfreie Verdringung unserer Produkte sind nur dann gewährleistet, wenn die Verarbeitung auf STOCKO-Werkzeugen erfolgt.

UL approvals and correct crimping only ensured on products crimped with STOCKO applicators.

	Richtig Correct	Falsch Incorrect	Falsch Incorrect	Crimphöhen-Messung* Measuring the crimp height*
Drahtcrimp Conductor crimp		 Crimphöhe zu hoch Volumen zu klein Crimp height too high Volume too small	 Überpressung! Volumen zu klein Stempelverschleiß Over-crimped! Volume too small Worn punch	 Drahtcrimp Wire crimp
Isolationscrimp Insulation crimp		 Volumen zu klein Volume too small	 Crimphöhe zu niedrig Volumen zu klein Crimp height too low Volume too small	
		 Volumen zu groß Volume too large		 Isolationscrimp Insulation crimp
		 Volumen zu groß Volume too large	 Crimphöhe zu hoch Volumen zu klein Crimp height too high Volume too small	
Längeneinstellung Length adjustment		 Zu weit eingelegt Isolation im Drahtcrimp Cable inserted too deep Insulation in wire crimping bucket	 Nicht weit genug eingelegt Isolation nicht sichtbar Cable inserted not deep enough Insulation invisible	

Leiterauszugskraft:

Eine Kontrollmessung ohne Isolationskralle wird mit dem entsprechenden Gerät vorgenommen.
Die Meßwerte sind mit den Angaben des Crimp-Datenblattes zu vergleichen.

Tensile strength (crimped conductor)

Tension of conductor crimp to be measured with a suitable instrument (without insulation crimp).
The values obtained are to be compared with the specification of the data sheet.

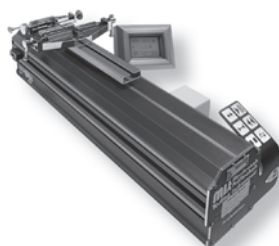

*Crimphöhen-Messung

*Measuring the crimp height

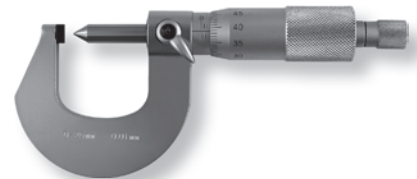

Die Anwendungsparameter von Steckverbindern und Kontakten werden in Datenblättern und Katalogen definiert. STOCKO-Produkte sind darauf ausgelegt, innerhalb der vorgegebenen Spezifikationen betrieben zu werden. Jede Anwendung unserer Produkte außerhalb der in den Spezifikationen zugelassenen Grenzwerte kann gefährlich sein und die Nichtbeachtung der folgenden Hinweise kann deshalb schwerwiegende Folgen haben.

Eigenschaften der eingesetzten Materialien

Verwendet werden flammgeschützte thermoplastische Isolationswerkstoffe, Kontaktmaterialien auf Kupfer- oder Stahlbasis und Oberflächenbeschichtungen aus Zinn, Nickel oder Gold. In Einzelfällen, z.B. bei kundenspezifischen Produkten, können auch andere hier nicht aufgeführte Materialien zum Einsatz kommen. Die für die jeweiligen Produkte eingesetzten Materialien können je nach Anwendung variieren und auf die spezifischen Anforderungen abgestimmt sein.

Wenn die Steckverbinder und Kontakte in den in Spezifikationen und Datenblättern angegebenen Grenzen betrieben werden, bleiben die technischen Eigenschaften langfristig stabil. Werden jedoch durch besondere Betriebsbedingungen oder im Störfall die Grenzwerte überschritten oder die Steckverbinder und Kontakte z.B. extremen Umweltbedingungen ausgesetzt, können sich die Eigenschaften der eingesetzten Materialien verändern.

Die fehlerhafte Kontaktierung eines Leiters mit ungeeigneten Werkzeugen, deformierte oder gebrochene Kontakte, Überschreitung der zulässigen Strombelastung, unvollständige Steckung der Stecker und Kontakte oder schlecht gelötete Kontakte können zu einer Überschreitung der zulässigen Grenztemperatur einer Steckverbindung oder eines Kontaktes führen. In diesen Fällen kann das Isolationsmaterial in seinen elektrischen Eigenschaften beeinträchtigt werden und bei Berührung die Gefahr eines elektrischen Schlags bestehen.

Hält eine Überhitzung über die spezifizizierte Grenztemperatur längere Zeit an, baut sich die Kontaktkraft der Federkontakte ab und Oxidschichten bilden sich auf Kontakten und Drähten. Der Kontaktwiderstand steigt dadurch an, weitere Temperaturerhöhungen sind die Folge und das Isolationsmaterial kann bis hin zur Verkohlung geschädigt werden. Auf Grund dieser thermischen Schädigung des Isolationsmaterials können sich Kriech- oder Leckströme bilden. Dabei können Flammen entstehen, die brennbares Material in der Umgebung entzünden und unter Umständen Brände auslösen.

Eine sorgfältige Behandlung von Steckverbindern und Kontakten auf dem Transport, in der Verarbeitung und in der Anwendung ist deshalb unbedingt notwendig. Beschädigungen können Gefährdungen nach sich ziehen. Vor dem Einbau sollten die Produkte deshalb geprüft und im Falle von fehlerhafter Verarbeitung oder vorhandener Beschädigung nicht weiterverwandt werden.

The suitability parameters for connectors and contacts are defined in the data sheets and catalogues. STOCKO products are designed to meet these specifications. To employ our products outside the specified parameters can be dangerous and neglecting the following information can have serious consequences.

Properties of the materials employed

Materials used are thermoplastic insulation materials, contact materials based on copper or steel, and tin, nickel or gold surface finishes. Under special circumstances, like products to customers' specification, also other materials than those mentioned may be used. The selected materials for individual products can vary, being tuned according to application.

Provided connectors and contacts are used within the specified limits of the data sheets, the technical properties will remain stable over a long period of time. If, however, these limits are exceeded due to special circumstances or faulty production or due to exposure to extreme environmental conditions, the properties of the materials may change.

The faulty termination of contact and conductor with unsuitable tools, deformed or broken contacts, excessive current load, unfinished connections of connectors and contacts or badly soldered contacts can lead to exceeding the permissible temperature range of the connector or contact. In such event the insulating material may be impaired and, if touched, the danger of electric shock may exist.

Over-heating due to exceeding the specified temperature limits over a longer period will result in a reduction of the contact force of contacts and an oxide layer will build up on contacts and conductors. The contact resistance will increase and further temperature rises will result in damaging the insulating material with the danger of charring. Creeping or leakage currents can be formed owing to the thermal damaged insulation. This may cause combustion that ignites the surrounding inflammable material and may even start a fire.

A careful handling of connectors and contacts in all stages of transport, manufacture and application is absolutely important. Damaged components can create dangers. The products, therefore, should be examined before assembly and must not be further processed, if badly terminated or defective.





Verarbeitung / Kabelbaumherstellung

Nur sorgfältig verarbeitete Steckverbinder und Kontakte erfüllen in der Anwendung die technischen Anforderungen. STOCKO-Ansetzwerkzeuge und -Maschinen sind auf die besonderen Produkteigenschaften abgestimmt. Prüfstationen überwachen die Qualitätsparameter, um eine hochwertige Verarbeitung der Steckverbinder und Kontakte sicherzustellen.

Für die Einhaltung der STOCKO-Qualitätskriterien auf Verarbeitungseinrichtungen anderer Hersteller trägt der Anwender die alleinige Verantwortung.

- Nur geschultes Personal sollte Steckverbinder und Kontakte verarbeiten.
- Bei der Verarbeitung von Steckverbindern und Kontakten müssen die STOCKO-Verarbeitungsspezifikationen berücksichtigt werden.
- Die Überwachung der produktspezifischen Qualitätsparameter muss nach STOCKO-Vorgaben erfolgen.
- Die eingesetzten Leitungen müssen von STOCKO für das jeweilige Steckverbindersystem oder den Kontakt freigegeben sein.
- Stellen Sie sicher, dass die Isolationsfähigkeit des Steckers nicht durch niederohmige Verbindungen wie Metallspäne, leitende Betriebsstoffe, lose Litzen oder leitende Verunreinigungen herabgesetzt ist, bevor die Stromkreise eingeschaltet werden.

Steckverbinder und Kontakte in der Anwendung

In der Anwendung muss sichergestellt werden, dass die Steckverbinder und Kontakte spezifikationsgemäß eingesetzt werden.

- Die bestimmungsgemäße Funktion einer steckbaren Verbindung wird nur gewährleistet, wenn die Verbindung nach den Vorgaben montiert ist.
- Die zulässige Betriebsspannung hängt von der jeweiligen Anwendung, den gültigen nationalen Bestimmungen und anderen anwendbaren Sicherheitsbestimmungen ab. Die angegebene Betriebsspannung kann deshalb nur als Anhaltswert dienen und muss mit den nationalen Bestimmungen abgeglichen werden.
- Die in den Datenblättern und Spezifikationen angegebenen Temperaturwerte sind Grenztemperaturen und dürfen in der Anwendung nicht überschritten werden.
- Eine Verschmutzung der Steckverbinder und Kontakte darf den jeweils zulässigen Verschmutzungsgrad nicht überschreiten (siehe IEC 60 664). Leitende Verschmutzungen können Kriechströme verursachen. Dabei können Flammen entstehen, die brennbares Material in der Umgebung entzünden und Brände auslösen können.
- Eingeschaltete Stromkreise dürfen nicht durch Abziehen eines Steckers unterbrochen werden. Lichtbögen, Ionisation und ein Brand kann die Folge sein.
- Die Steckverbinderkomponenten mit berührbaren Kontakten sollten nicht auf der Stromversorgungsseite eingesetzt werden, da bei ungesteckten Verbindungen die Gefahr eines elektrischen Schlags besteht.

Sonstige Hinweise

Durch den ständigen Verbesserungsprozess können sich die Produkte ändern. Abweichungen von Beschreibungen, technischen Daten und Darstellungen in den Katalogen sind deshalb möglich. Jede neue Ausgabe eines Kataloges macht vorausgehende Ausgaben ungültig.

Harness processing assembly

Carefully processed connectors and contacts alone will meet the technical requirements in usage. STOCKO assembly tools and machines are adjusted to the specific product properties. Test stations control the quality parameters to safeguard the quality in processing the connectors and contacts.

To assure the STOCKO-quality requirements on processing devices of other manufacturers the user has to take sole responsibility.

- Only trained personnel should process connectors and contacts.
- Processing connectors and contacts the STOCKO manufacturing specifications must be observed.
- Product specific quality parameters must be controlled in accordance with STOCKO instructions.
- Conductors used with the respective connector system or contact must be approved by STOCKO.
- Before switching on the electric current, make sure that the insulating properties of the connector are not compromised by low ohmic connections like metal shavings, conductive materials, lose wires or conductive impurities.

Application of connectors and contacts

When in use make sure that connectors and contacts are applied according to specification.

- The pre-determined function of a connector assembly can only be guaranteed if the connection is assembled according to instruction.
- The permissible operating voltage is subject to application, the legal national specifications and any other applicable safety requirements. The mentioned operating voltage can only serve as a guidance and must be adjusted to national requirements.
- The temperature values indicated in the data sheets are border-line temperatures and must not be surpassed under operating conditions.
- Contaminated connectors and contacts must not exceed the permissible degree of contamination (see IEC 60 664). Conductive contaminations can lead to creepage currents. They can create combustions that inflame surrounding inflammable materials and start fires.
- Switched-on circuitry must not be interrupted by pulling the plug. The result may be electric arcs, ionisation and fires.
- Connector components with touchable contacts must not be used as mains connections as unplugged connections can endanger electric shocks.

Further Information

The products can be changed due to improvements. Changes and alterations from descriptions, technical data and illustrations in the catalogues are possible. Every new catalogue will make all earlier published versions invalid.

Deutschland / Germany

Hauptsitz
STOCKO Contact GmbH & Co. KG
Simonshöfchen 31
42327 Wuppertal
Tel.: +49 202 9733 - 2
Fax: +49 202 9733 - 411
E-Mail: info@stocko-contact.com

P STOCKO Contact GmbH & Co. KG
Olefallstr. 26
53940 Hellenthal
Tel.: +49 2482 84 - 0
Fax: +49 2482 84 - 240
E-Mail: hellenthal@stocko-contact.com
E-Mail: service-idc@stocko-contact.com

D Lorenzgroup Electronic
Distribution und Vertriebsgesellschaft mbH
Schieferstein 6
65439 Flörsheim
Tel.: +49 6145 9599-0
Fax: +49 6145 9599-40
E-Mail: info@lorenzgroup.com

D HZ GmbH
Technische Kunststoffe & Elektrische
Verbindungstechnik
Johannes-Giesser-Straße 11
71364 Winnenden-Hertmannsweiler
Tel.: +49 7195 59069 - 22
Fax: +49 7195 59069 - 29
E-Mail: mail@hz-gmbh.com

R Hoppe & Co. Electronic
Inhaber Hans Zeltner e.K.
Thomas-Mann-Straße 50
90471 Nürnberg
Tel.: +49 911 327175
Fax: +49 911 327141
E-Mail: info@hoppe-electronic.de

D zeb elektroTECHNIK GmbH
Thomas-Mann-Straße 50
90471 Nürnberg
Tel.: +49 911 323957-0
Fax: +49 911 327141
E-Mail: info@zeb-gmbh.de

D ETB Electronic Team
Beratungs- und Vertriebs GmbH
Wundramweg 1
31303 Burgdorf
Tel.: +49 5136 97229-0
Fax: +49 5136 972 9-39
E-Mail: info@etb-electronic.de

Australien / Australia

D Braemac Pty Ltd
1/59-61 Burrows Road, Alexandria
Sydney, NSW 2015 Australia
Tel.: +61 2 95506600
Fax: +61 2 95506377
E-Mail: info@braemac.com.au

Belgien, Luxemburg Belgium, Luxembourg

R ATEM N.V./S.A.
Bedrijvenpark De Veert 4
B-2830 Willebroek
Tel.: +32 03 8661800
Fax: +32 03 8661828
E-Mail: info@atem.be

Brasilien, Südamerika Brazil, South America

SD STOCKO CONTACT Brasil Ltda.
Av. Paulista, 1439 – 1º andar CJ12
01311-200 São Paulo / SP / Brasil
Tel.: +55 11 4890 2223
Mobil: +55 11 94251 2450
E-Mail: brazil@stocko-contact.com

China / China

R STOCKO Contact GmbH & Co. KG
c/o Wieland Electric
Trading (Shanghai) Co. Ltd.
7F, East Huaihai Int'l Mansion,
No 49 Huaihai Road (E),
Huang Pu District, Shanghai
200010, PRC
Tel.: +86 21 63555772-127
63555772-127
Fax: +86 21 6355 0090
Mobil: +86 136 36435222
E-Mail: china@stocko-contact.com

SD STOCKO Contact GmbH & Co. KG
#3-601, No.42 Dongshan 4th Road,
Qingdao 266100, P.R.China
Mobil: +86 139 69760609
Fax: +86 532 / 66870622
E-Mail: china@stocko-contact.com

SD STOCKO Contact GmbH & Co. KG
No 147-149, Changping Avenue,
Lian Guan Plaza, Room 1520,
Guangdong Province, Dongguan City,
Changping Town 523560,
P.R.China
Mobil: +86 137 1278 7427
E-Mail: china@stocko-contact.com

SD STOCKO Contact GmbH & Co. KG
Unit 08-1-302, No.184 Taishan Road
New district Changzhou 213022,
P.R.China
Mobil: +86 136 85216240
E-Mail: china@stocko-contact.com

D WG Industrial Control Equipment
Suit. 22, No. 328, Hengyong RD
Jiading District
201806 Shanghai, P.R.China
Tel.: +86 21 34533671
Fax: +86 21 34311361
E-Mail: sales@wg-ind.com

Dänemark / Denmark

R MATECH SYSTEMS A/S
D Ankelbovej 6
7190 Billund
Denmark
Tel.: +45 75 338949
Fax: +45 75 338946
E-Mail: info@matechsystems.dk

Estland, Lettland, Litauen Estonia, Latvia, Lithuania

R Adcontact/Gammeter
Paldiski mnt 31
EE - 76606 Keila, Harjumaa
Tel.: +372 671 2251
Fax: +372 671 2253
Mobil: +372 50 89343
E-Mail: info@gammeter.ee

Finnland / Finland

R Adcontact AB Filial I Finland
GAMMETER
Vehnämlylynkatu 6
FIN-33560 Tammerfors
Finland
Tel.: +358 3 3802211
Fax: +358 3 3802244
E-Mail: info@gammeter.fi

Frankreich / France

S STOCKO CONTACT Eurl
7, Route d'Eichhoffen
CS 40017 Andlau
67145 - BARR Cedex
Tel.: +33 388 585858
Fax: +33 388 585888
E-Mail: andlau@stocko-contact.com

R M. Roland DOTIGNY
4 Rue Rougette
60240 Liancourt St Pierre
Tel.: +33 3 44479168
Fax: +33 3 44479168
E-Mail: roland.dotigny@stocko-contact.com
(Parisienne, Ouest, Normandie, Nord)

R CONNECT-SYSTEMES
D 31, Impasse de la Balme
69800 Saint-Priest
Tel.: +33 4 78901315
Fax: +33 4 78906332
E-Mail: commercial@connect-systemes.fr
(Röhne-Alpes, Sud, Centre, Est)

Griechenland / Greece

R S. SAKELLIYOU & CO O.E.
Manufacturer's Agents
15B Konstantinidou str.
K. Patissia 104 45 - Athens
Tel.: +30 2 108322611
Fax: +30 2 108325444
E-Mail: info@sasta.gr

Großbritannien / Great Britain

D Cabletrix Ltd.
9/10 James Watt Close
Drayton Field Industrial Estate
Daventry, Northants NN11 8QU, UK
Tel.: +44 1327 876769
Fax: +44 1327 300130
E-Mail: sales@cabletrix.co.uk

D J-Tronics Ltd
1 Granger Avenue
Acomb
York, YO26 5LF, UK
Tel.: +44 1904 795690
Fax: +44 1904 790887
E-Mail: julie@j-tronics.co.uk
If you need a design partner
for harnesses contact:
garth@j-tronics.co.uk

D New Force Ltd
Fair Crest
Conghurst Lane
Hawkhurst
Cranbrook
Kent
TN18 5DZ
Tel.: 01580 752014
E-Mail: sales@new-force.co.uk

Indien, Sri Lanka, VAE / India, Sri Lanka, UAE

D AURO CONTROLS PRIVATE LIMITED
Florina Apartment, 6th Floor,
Survey No. 2/1/7, Erandwane,
Pune 411004 INDIA
Tel.: +912025465915
E-Mail: sales@aurocontrols.com

Indonesien / Indonesia

D PT. Esecodharma Permai
Green Sedayu Biz Park Daan Mogot
Jl. Raya Daan Mogot KM.18
Blok DM-2 No.18, Jakarta Barat, 11840
Tel.: +62 21 5696 8822
Fax: +62 21 5696 8811
E-Mail: eseco-mkt@eseco.co.id

Irland, Republik / Irland, Republik of

D Cabletrix Ltd.
9/10 James Watt Close
Drayton Field Industrial Estate
Daventry, Northants NN11 8QU, UK
Tel.: +44 1327 876769
Fax: +44 1327 300130
E-Mail: sales@cabletrix.co.uk

Italien / Italy

R KLEMI Contact Srl
D via Monferrato, 43
20098 San Giuliano Milanese (MI)
Italy
Tel.: 39-02-5560.6101
Fax: +39-02-5560.7134
E-Mail: klemi@klemi-contact.com

Japan / Japan

SD STOCKO CONTACT GmbH & Co.KG
c/o Wieland Electric Co., Ltd.
Nisso No. 16 Bldg. 3-8-8
Shin-Yokohama Kohoku-ku Yokohama
222-0033 Japan
Tel.: +81-45-473-5085
Fax: +81-45-470-5408
E-Mail: japan@stocko-contact.com

Kanada / Canada

R WIELAND Electric Inc.
2889 Brighton Rd.
Oakville, ON L6H 6C9
Tel.: (905) 829-8414 or 1-800-Wieland
Fax: (905) 829-8413
E-Mail: technical.support@
wieland.electric.com

Korea / Korea

D Sam Tra International
Hoseo Venture Tower 609 Ho
319 Gasan-dong
Geumcheon-gu, Seoul 153-711
Korea
Tel.: +82 2 26275625
Fax: +82 2 26275629
E-Mail: sales@samtra.co.kr

- (D)** Distribution / Distribution
- (P)** Zweigwerk / Plant
- (R)** Vertretung / Representation
- (S)** Tochtergesellschaft / Subsidiary
- (SD)** Vertriebsbüro / Sales Office

(SD) Stocko Contact GmbH & Co. KG
Korea Office
Level 41, Gangnam Finance Center
152 Teheran-ro, Gangnam-gu,
Seoul 06236
Korea
Tel.: +82 2 2008 4580
Mobil: +82 10 5809 5970
Fax: +82 2 2008 4555
E-Mail: korea@stocko-contact.com

Kroatien, Slowakei, Slowenien, Tschechien
Croatia, Slovakia, Slovenia, Czech Rep.

(via Codico Partner)

(D) CODICO GmbH
Zwingenstraße 6-8
A-2380 Perchtoldsdorf
Tel.: +43 01 86305-0
Fax: +43 01 86305-5000
E-Mail: office@codico.com

Malaysia / Malaysia

(D) C.T.M. Industries Sdn. Bhd
(Penang Office)
14 & 16 Lorong Nagasari 4,
Kawasan Perusahaan Prai,
13600 Prai, Malaysia.
Tel.: +60 4 397 9202
Fax: +60 4 397 9155
E-Mail: pg-ctm@ese-group.com

(D) C.T.M. Industries Sdn. Bhd
(Kuala Lumpur Office)
Suite 719, Blk B2,
Leisure Commerce Square,
No. 9, Jalan PJS 8/9,
46150 Petaling Jaya,
Selangor Darul Ehsan, Malaysia.
Tel.: +60 3 7875 3212
Fax: +60 3 7875 3302
Email: pg-ctm@ese-group.com

Mexiko / Mexico

(SD) STOCKO CONTACT GmbH & Co. KG
Sales Office Texas
El Paso
Cell: +1 915 309 5363
E-Mail: Mexico@stocko-contact.com

Niederlande

(D) AVT Industrial Components
Freddy van Riemsdijkweg 7
5657 EE Eindhoven
Tel.: +31 40 2088088
Fax.: +31-40-2088099
E-Mail: sales@avtic.com

Norwegen / Norway

(R) Adcontact/Gammeter
(D) P.O. Box 246 Skøyen
N-0213 Oslo
Tel.: +47 22417700
Fax: +47 22417701
E-Mail: info@adkontakt.se

Österreich / Austria

(D) CODICO GmbH
Zwingenstraße 6-8
A-2380 Perchtoldsdorf
Tel.: +43 01 86305-0
Fax: +43 01 86305-5000
E-Mail: office@codico.com

Philippinen / Philippines

(D) C.T.P. Industries, Inc
Unit # 1001 Primeland Tower,
2218 Market Street,
Madrigal Business Park, Ayala Alabang,
Muntinlupa City, Philippines 1771
Tel.: +63 2 245 0632 / 245 0639
Fax: +63 2 836 7968
E-Mail: admin@ctp.com.ph

Polen / Poland

(R) EVOLTEC Tomasz Pawlowski
(D) ul. Bekasów 63/65
02-803 Warszawa
Tel.: +48 22 550 27 40-44
Tel.: +48 22 550 27 47
Fax: +48 22 550 27 45
E-Mail: info@evoltec.pl

Portugal / Portugal

(SD) STOCKO CONTACT GmbH & Co. KG
Vertriebsbüro Spanien / Portugal
F. Rius i Tauler, 19-3°
E-08850 Gavà (Barcelona)
Tel.: +34 936 627188
Fax: +34 936 627188
Mobil: +34 676 490974
E-Mail: spain@stocko-contact.com

Russland / Russia

(D) CE Engineering
Krasnokazarmennaya 3 build 5
Moscow 111250
Russia
Tel.: +7 495 2563541
Fax: +7 495 9671561
E-Mail: info@faston.ru

(D) ELCO Group LLC
13A, Building 4, Structure 4
Varshavskoye Shosse
Moscow 115230
Tel.: +7 495 9818516
Fax: +7 495 7750255
E-Mail: info@elcogroup.ru

Weißrussland / Belarus

(D) FEK Company
Pushkina 29-B
220016 MINSK
Belarus
Tel.: +375 17 2102189
Fax: +375 17 2102189
E-Mail: info@fek.by

Schweden / Swede

(R) Adcontact/Gammeter
(D) Ursviksv. 127B
P.O. Box 7044
S-17407 Sundbyberg
Tel.: +46 8 4453600
Fax: +46 8 4453610
E-Mail: info@adcontact.se

Schweiz / Switzerland

(R) AWAG Elektrotechnik AG
(D) Sandbühlstrasse 2
CH-8604 Volketswil
Tel.: +41 044 9081919
Fax: +41 044 9081999
E-Mail: info@awag.ch

Singapur / Singapore

(SD) STOCKO CONTACT GmbH & Co. KG
Liaison Office Singapur
Blk 5, Rivervale Crescent
08-05 Singapore 545084
Mobil: +65 91 832131
E-Mail: singapore@stocko-contact.com

(D) C.T.S. Industries Pte Ltd
47 Kaki Bukit Place,
Eunos Techpark,
Singapore 416225
Tel.: +65 6276 3328
Fax: +65 6276 3336
E-Mail: sales_cts@ese.com.sg

(D) Seap Trading Pte. Ltd.
16 New Industrial Road # 05-02
Hudson Techno Centre
Singapore 536204
Tel.: +65 6345 1788
Fax: +65 6348 6116
E-Mail: info@seaptrading.com.sg

Spanien / Spain

(SD) STOCKO CONTACT GmbH & Co. KG
Vertriebsbüro Spanien / Portugal
F. Rius i Tauler, 19-3°
E-08850 Gavà (Barcelona)
Tel.: +34 936 627188
Fax: +34 936 627188
Mobil: +34 676 490974
E-Mail: spain@stocko-contact.com

(D) TC Componentes, S.L.
Cami de Can Calders,6 12-G
E-08173 Sant Cugat del Vallès
Barcelona
Tel.: +34 93 590 28 30
Fax: +34 93 590 02 67
E-Mail: info@tc-componentes.es

Südafrika / South Africa

(R) APT Advanced Product Technology (PTY)
LTD.
Strijdom Park, Randburg
P.O. Box 832
Ferndale 2160
Tel.: +27 11 7926010
Fax: +27 11 7929879
E-Mail: craig@aptsa.co.za

Thailand / Thailand

(D) ST Global Industries Co., Ltd.
36 Moo 4, Tambon Pimpha
Amphur Bangpakong
Chachoengsao, 24130
Thailand
Tel.: +66 38 595983
Fax: +66 38 595363
E-Mail: stglobal@st-global.co.th

Taiwan / Taiwan

(D) Cian Shin Industrial Co.,LTD
4F., No.33, Ren'ai St. Tamsui Dist.,
New Taipei City 25168 Taiwan (R.O.C.)
Tel.: +886 2 26230681
Fax: +886 2 26231920
E-Mail: sales@cianshin.com.tw

Türkei / Turkey

(SD) STOCKO CONTACT GmbH & Co. KG
Istanbul Liaison Office
Atakoy 11. Kısım, Cıgdem D Blok, D:33
34158 Istanbul / TURKIYE
Tel.: +90 212 6618710
Fax: +90 212 6618720
E-Mail: info@stockotr.com

Ungarn / Hungary

(R) CZINEGE és FIAI Kft.
(D) Pesti ucta 36,
H-5100 - Jászberény
Tel.: +36 057 500190
Fax: +36 057 500191
E-Mail: czinege@czinege.hu

USA / USA

(SD) STOCKO CONTACT GmbH & Co. KG
Sales Office Michigan
Detroit
Tel.: +1 248 5719596
E-Mail: usa@stocko-contact.com

(SD) STOCKO CONTACT GmbH & Co. KG
Sales Office Illinois
Chicago
913 N Neva Ave
Addison, IL 60101
Tel.: +1 630 5185089
E-Mail: usa@stocko-contact.com

(SD) STOCKO CONTACT GmbH & Co. KG
Sales Office Texas
El Paso
Tel.: +1 915 309 5363
E-Mail: usa@stocko-contact.com

(SD) STOCKO CONTACT GmbH & Co. KG
Sales Office Kentucky
Morehead
Tel.: +1 606 356 3499
E-Mail: usa@stocko-contact.com

Vietnam / Vietnam

(D) C.T.S. Industries (Indochina) Co., Ltd
(Hanoi Head Office)
165 Thai Ha Street, Lang Ha Ward,
Song Hong Land Office Building,
Unit 2, 5th Floor,
Dong Da District, Hanoi, Vietnam
Tel.: +84 4 3203 2999
Fax: +84 4 3201 2999
E-Mail: sales@ctsindochina.com.vn

(D) C.T.S. Industries (Indochina) Co., Ltd
(Ho Chi Minh Branch Office)
5th Floor, Mekong Tower,
235 - 241 Cong Hoa Street.,
Tan Binh District,
Ho Chi Minh City, Vietnam
Tel.: +84 8 3600 0826
Fax: +84 8 6281 6568
E-Mail: sales@ctsindochina.com.vn

STOCKO CONTACT
GmbH & Co. KG

Simonshöfchen 31
D-42327 Wuppertal

Tel. +49 202 9733 - 2
Fax +49 202 9733 - 411

E-Mail info@stocko-contact.com
Internet www.stocko-contact.com

Ein Unternehmen der Wieland Gruppe
A Member of the Wieland Group

